

FEATURES

- Self-powered, requires only two connections
- Auto-ranging 6 to 75Vdc input range
- Installs in round "oiltight" 1.20 inch (30.5mm) cutouts
- Reverse polarity protected to -100Vdc
- Four-digit LED display with overvoltage indication
- Digital replacement for analog panel meters
- Screw-style terminal block simplifies installation
- Self-resetting internal fuse for long-term reliability
- Provides moisture resistance to IP67/NEMA 6
- Supplied with EPDM rubber gasket and plastic hex nut
- Panel knockout punches and tooling available



Performance/Functional Specifications

Typical at Ta = +25°C, unless otherwise noted

DC Input (TB1)

Input voltage range ①	+6 to +75Vdc
Current Consumption	@Vin = 75.0Vdc: 7mA (max.)
Reverse Polarity Protection	-100Vdc (min.)

Performance

Sampling Rate	2.5 readings/second
Resolution	0.01Vdc in LO Range; 0.1Vdc in HI Range

Accuracy @ +25°C

HI Range ②	±0.2V (typ.), ±0.4V (max.)
LO Range ②	±0.03V (typ.), ±0.06V (max.)
Overrange Indication ③	See note 3
Temperature Drift	±0.003V/°C (typ.)

Mechanical

Dimensions	1.50" diameter x 1.08 depth" (38.1 x 27.4mm)
Display Type	Four digit, LED, 0.30" high (7.6mm)
Weight	0.6 ounces (18 grams) with nut and gasket
Case Material	Polycarbonate
Terminal Block Torque	3.6 in-lbs (0.4 N-m)
Wire Size And Type	18-22AWG (0.83-0.33mm ²) copper, solid or stranded
Wire Insulation Strip Length	0.25" (6.4mm)

Environmental

Operating Temperature	-25 to +60°C
Storage Temperature	-40 to +75°C
Humidity (non-condensing)	0 to 85%

① Operation and accuracy at inputs above or below these ranges are not specified.
 ② When auto-range operation is enabled via jumper JP1 and Vin is between 6V to 51V, the displayed resolution is 0.01V (i.e., the unit is in LO Range). When Vin is 51V and above, display resolution is 0.1V (i.e., the unit is in HI Range). When the unit is in the HI range and Vin drops below 49V, it will auto-range back to the LO Range.
 ③ When Vin is between 75V and 80V, the display will alternate from dim to normal intensity at approximately one second intervals. When Vin exceeds 80V, display will flash on and completely off at approximately one second intervals. Continuous operation above 80V will permanently damage the meter and void its warranty.

Murata Power Solutions' new DMR20-10-DCM self-powered, auto-ranging DC voltage monitors are designed to measure and display the outputs the most popular DC power systems. Simply connect any 6 to 75V DC power source and these meters are fully operational—no additional components or power sources are required.

Their large, 0.30"/7.6mm, bright LED displays can be easily read from 10 feet away (3 meters). These auto-ranging meters accurately display DC voltages with 0.01V in the LO Range (below 51V), or 0.1V resolution in the HI Range (above 51 V). A built-in resettable fuse assures long term reliability. All DMR20-10-DCM's employ a 13-bit A/D converter and precision metal-film resistors to achieve outstanding performance over an operating temperature range of -25 to +60°C.

The DMR20-10-DCM is housed in a rugged, round polycarbonate case that provides excellent protection against moisture, dust, shock and vibration. Panel installation is straightforward: using readily available tooling, simply drill and punch a 1.2 inch (30.5mm) diameter hole and anti-rotation notch, insert the meter and gasket into the panel, and securely fasten the meter using the supplied hex nut. The supplied hardware is designed to provide protection to IP67/NEMA 6.

Ordering Information

DMR20-10-DCM-R-C 6 to 75Vdc voltage monitor (Red LED)

Tooling

DMR20-1-KP	1.2" (30.5mm) Round knockout punch (no keying notch)
DMR20-2-KP	1.2" (30.5mm) Round knockout punch (with four keying notches)
DMR20-3-KP	1/8" and 3/16" (3.2 and 4.7mm) key-notch nibbler tool

Note: An M30 x 1.5 nylon hex nut and EPDM sealing gasket are supplied with each meter. The "-C" suffix denotes RoHS compliance.



For full details go to
www.murata-ps.com/rohs

TECHNICAL NOTES



IMPORTANT! To ensure safe and reliable operation, DMR20-10-DCM DC voltage monitors must be installed and serviced by qualified technical personnel. Contact Murata Power Solutions if there is any doubt regarding installation or operation.

1. Operating Input Range: The unit is shipped with auto-range jumper JP1 in the open position. With JP1 open, auto-range operation is disabled and the unit will display input voltages between +6 to +75Vdc with a fixed 0.1V resolution. Changes to JP1's configuration must only be made when the unit is off (de-energized). The unit will not recognize JP1 configuration changes made with power applied to TB1.

Closing jumper JP1 (see Figure 1) places the unit in the auto-range mode of operation. With auto-range enabled and Vin between +6V to +51V, the displayed resolution is 0.01V (i.e., the unit is in LO Range). When the unit is in LO Range and Vin is increased to +51V, it will auto-range to the HI range and display 0.1V resolution. When the unit is in HI range and Vin drops below +49V, it will auto-range back to the LO Range and display 0.01V resolution.

Operation below +6Vdc will produce a noticeably dimmer display and accuracy is not guaranteed. Continuous operation between +75 and +80Vdc, while not recommended, will not adversely affect the unit. See the "Performance/Functional Specifications" section for more information.

2. Calibration: DMR20-10-DCM voltmeters are factory calibrated; there are no provisions for calibrating these meters in the field.

3. Panel Installation: All electrical connections to DMR20-10-DCM must be made after the voltmeter is securely attached to the panel, and with the input DC input supply source de-energized (off). In high-vibration environments, adequate strain reliefs must be used on all supply wiring. See Figure 2 for typical panel mounting details.

Tightening Torque:

The recommended tightening torque for the M30 x 1.5 plastic hex nut is 10 to 17 in-lbs (1.3 to 1.9 N-m). If a torque wrench is not available, this recommended range can be approximated by hand tightening the hex nut SLOWLY until it just bottoms out against the panel's rear surface. From this bottomed-out reference position, using a suitable tool, tightening the hex nut ¼ turn clockwise will produce approximately 10 in-lbs (1.3 N-m) of torque; tightening it 3/8 turn clockwise will produce approximately 17 in-lbs (1.9 N-m).

Check to make sure the housing's anti-rotation key is aligned with the notches on both the panel and the gasket before tightening the hex nut. Over tightening the hex nut will distort the rubber gasket and may damage the threads on both the nut and the housing, thereby compromising the installation's mechanical integrity and its ability to protect against environmental effects.

Panel Thickness:

When using both the factory supplied EPDM gasket and hex nut (the recommended standard installation method), the DMR20-10-DCM can be mounted in panels ranging from 0.032" to 0.250" (0.8 to 6.4mm) thick. When the gasket is not used, the panel thickness range is 0.075" to 0.325" (1.9 to 8.3mm). However, using the factory supplied hardware and tightening torque recommendations results in optimal resistance to vibration, and dust and moisture ingress.

Panel Materials:

Acceptable panel materials include aluminum, mild steels, plastics, FR-4 pc-board (fiberglass), and many other materials with a flat matte surface on both sides of the cutout. The DMR-20-x-KP tools can be used with most panel materials except for stainless steel or other hardened metals.

DMR20-10-DCM has passed vibration testing combined with temperature cycling while mounted to the materials noted above, using the specified tightening torques. If the voltmeter will be mounted to extremely smooth or slippery surfaces, the user is advised to test the completed assembly under the environmental conditions expected in the end application.

4. Input Fusing and Wiring: DMR20-10-DCM voltmeters contain an internal, self-resettable fuse. However, the supply wires connected to input terminals TB1's "+" and "-" terminals must be fused with an external, user supplied, 0.25A/300V time delay/time lag fuse, in accordance with applicable regulatory codes.

All supply wiring must be rated for the voltages and currents they will conduct and comply with any code or application-mandated requirements pertaining to the user's specific installation. 300V, UL-rated hook-up wire suitable for the intended application is required. TB1 is to be used only for powering the meter's internal circuitry; it must not be used to supply power to external loads.

The recommended TB1 supply wire size is 18AWG to 22AWG (0.83mm² to 0.33mm²) solid or stranded copper wire. The supply wires must be properly stripped and attached to TB1 such that their insulation is not pinched by the screw terminal. Recommended insulation strip length is 0.25" (6.4mm). When using stranded wire, verify that there are no loose or stray strands that could potentially cause a short circuit across the DC supply input.

5. Input Polarity: The input terminal block TB1 is polarity sensitive, and connections to it must be made as shown in the Mechanical Specifications section of this data sheet. However, intermittent or continuous application of reverse-polarity voltages up to -100V will not damage the meter.

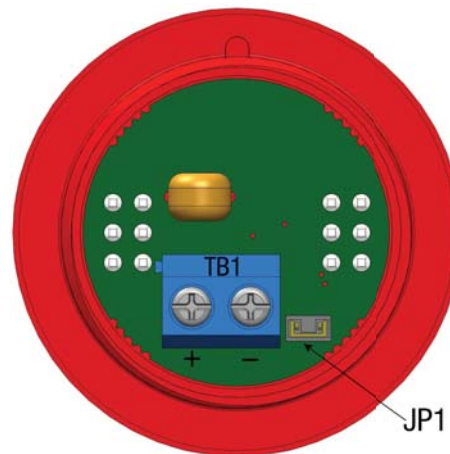

Figure 1. JP1 configured for auto-range operation

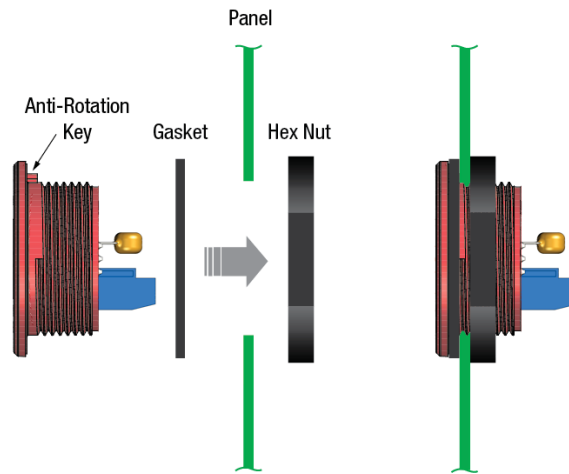
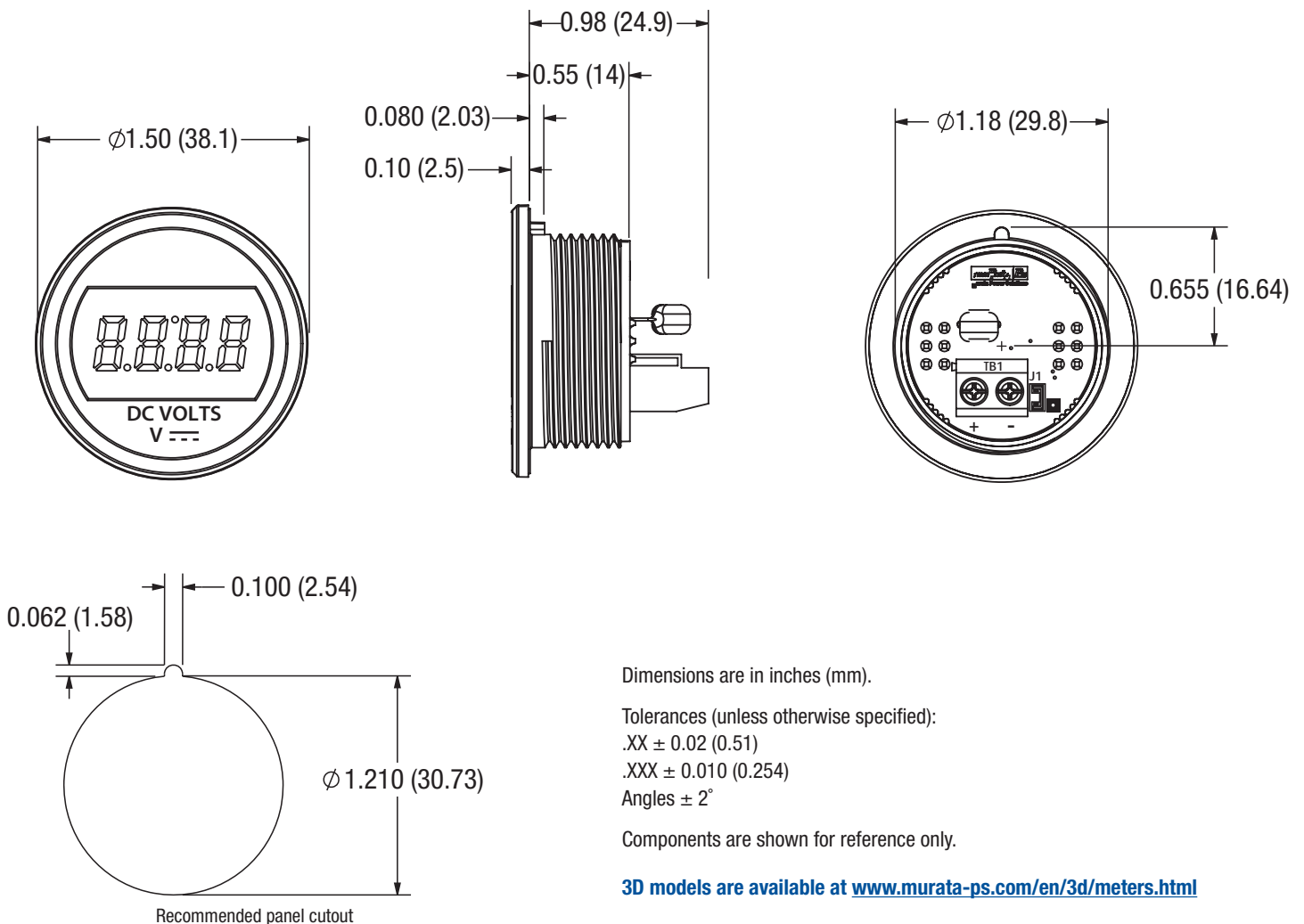

Figure 2. Panel Installation

MECHANICAL SPECIFICATIONS





NOTES

Mouser Electronics

Authorized Distributor

Click to View Pricing, Inventory, Delivery & Lifecycle Information:

[Murata:](#)

[DMR20-10-DCM-R-C](#)