

## DESCRIPTION

The EV4462DQ-00B is an evaluation board for the MP4462, a high frequency step-down regulator with an integrated power MOSFET.

The MP4462 integrates a 100mΩ MOSFET that provides 3.5A load current over a wide operating input voltage of 4.5V to 36V. A 5μA shutdown mode quiescent current allows use in battery-powered applications.

Current mode control provides fast transient response and eases loop stabilization. An internal soft-start prevents inrush current at turn-on.

The MP4462 is available in small 3mm x 3mm 10-pin QFN and thermally enhanced SOIC8 packages.

## ELECTRICAL SPECIFICATIONS

Parameter	Symbol	Value	Units
Input Voltage	$V_{IN}$	8 – 36	V
Output Voltage	$V_{OUT}$	3.3	V
Output Current	$I_{OUT}$	3.5	A

## FEATURES

- 3.5A Output Current
- Wide 4.5V to 36V Operating Input Range
- Adjustable Output from 0.8V to and up
- Up to 84.8% Efficiency at Full Load
- Up to 4MHz Programmable Switching Frequency
- All Ceramic Input and Output Capacitors
- Input Under Voltage Lockout
- Internal Soft-Start
- Available in a 10-Pin QFN (3mmx3mm) Package
- Fully Assembled and Tested

## APPLICATIONS

- High Voltage Power Conversion
- Game Machines
- Automotive Systems
- Industrial Power Systems
- Distributed Power Systems
- Battery Powered Systems

"MPS" and "The Future of Analog IC Technology" are Registered Trademarks of Monolithic Power Systems, Inc.

## EV4462DQ-00B EVALUATION BOARD



(L x W x H) 2.1" x 1.3" x 0.3"  
(5.3cm x 3.3cm x 0.7cm)

Board Number	MPS IC Number
EV4462DQ-00B	MP4462DQ

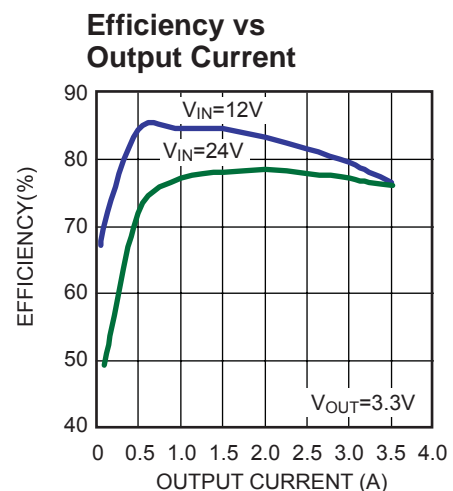

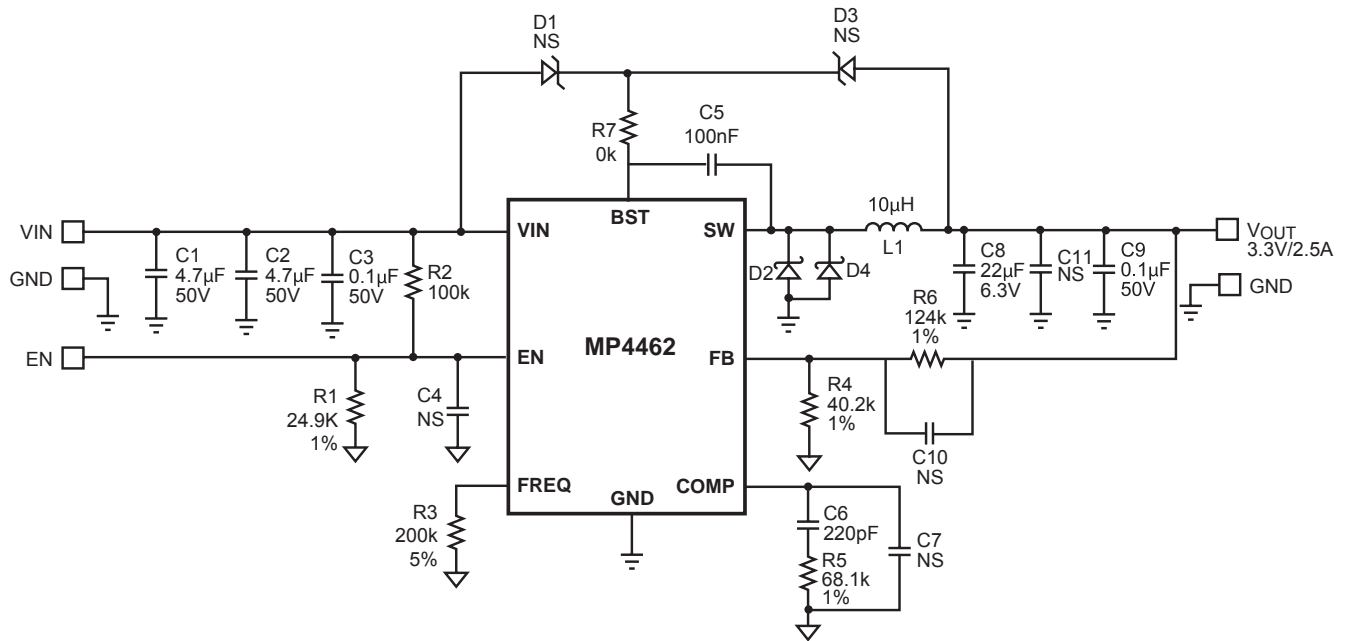
**EVALUATION BOARD SCHEMATIC**

**EV4462DQ-00B BILL OF MATERIALS**

Qty	Ref	Value	Description	Package	Manufacturer	Part Number
2	C1,C2	4.7uF	Ceramic Cap. 50V, X7R	1210	MuRata	GRM32ER71H475 KA88L
2	C3,C9	0.1uF	Ceramic Cap. 50V, X7R	O805	TDK	C2021X7R1H104K
4	C4,C7,C 10,C11		Do Not Stuff			
1	C5	100nF	Ceramic Cap. 50V, X7R	O603	TDK	C1608X7R1H104K
1	C6	220pF	Ceramic Cap. 50V, COG	O603	TDK	C1608COG1H221J
1	C8	22uF	Ceramic Cap. 6.3V, X5R	1210	TDK	C3225X5ROJ226M
3	D1,D3,D 4		Do Not Stuff			
1	D2		DiodeSchottky, 40V, 3A	SMC	Diodes Inc	B340-13-F
1	R1	24.9K	Film Resistor ,1%	O603	Panasonic	ERJ-3EKF2492V
1	R2	100K	Film Resistor, 1%	O603	Panasonic	ERJ-3EKF1003V
1	R3	200K	Film Resistor, 5%	O603	Panasonic	ERJ-3GEYJ204V
1	R4	40.2K	Film Resistor, 1%	O603	Panasonic	ERJ-3EKF4022V
1	R5	68.1K	Film Resistor, 1%	O603	Panasonic	ERJ-3EKF6812V
1	R6	124K	Film Resistor ,1%	O603	Panasonic	ERJ-3EKF1243V
1	R7	0R0	Film Resistor ,5%	O603	Panasonic	ERJ-3GEY0R00V
1	L1	10uH	Inductor, 4A	SMD	Sumida	CDRH8D43-100
1	U1	MP4462 DQ	Step-Down Regulator	QFN10	Monolithic Power Systems Inc.	MP4462DQ

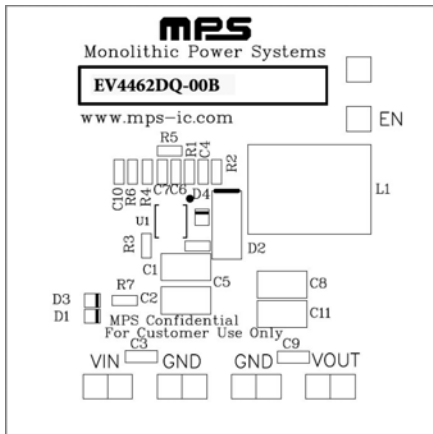
**PRINTED CIRCUIT BOARD LAYOUT**

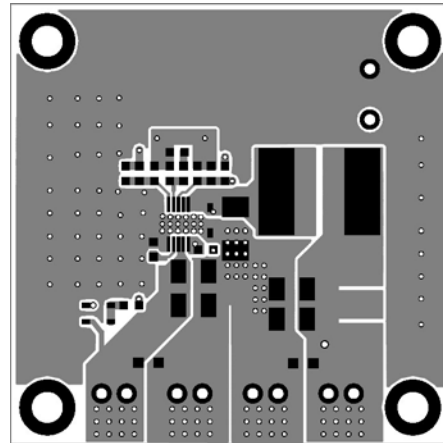

**Figure 1—Top Silk Layer**



**Figure 2—Top Layer**

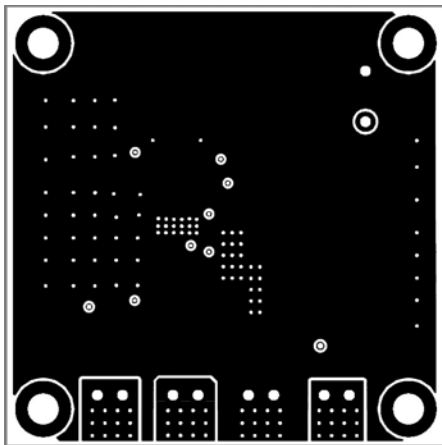

**Figure 3—Inner 1 Layer**

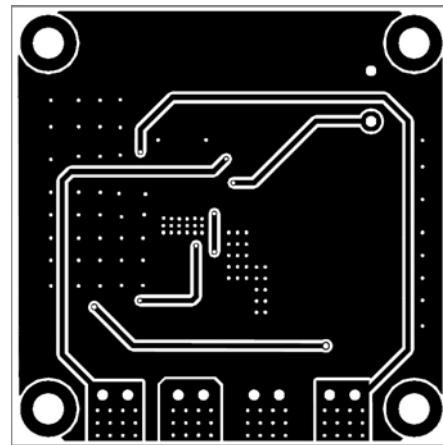

**Figure 4—Inner 2 Layer**

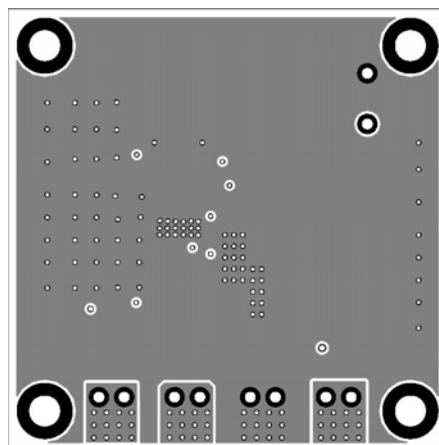

**Figure 5—Bottom Layer**

## QUICK START GUIDE

1. Connect the positive terminal of the load to VOUT pins, and the negative terminal of the load to GND pins
2. Preset the power supply output to 12V and turn off the power supply.
3. Connect the positive terminal of the power supply output to the VIN pin and the negative terminal of the power supply output to the GND pin
4. Turn the power supply on. The EV4462 will automatically startup.
5. To use the Enable function, apply a digital input to EN pin. Drive EN higher than 1.6V to turn on the regulator, drive EN less than 1.2V to turn it off.
6. An input under voltage lockout (UVLO) function is implemented by the addition of a resistor divider R1 and R2. The EN threshold is 1.2V (falling edge), so VIN UVLO threshold (falling) is  $1.2V \times (1+R2/R1)$ . It's preset to 6V on this board.

$$f_s(KHz) = \frac{70000}{R3(K\Omega)^{0.93}}$$

7. Use R3 to re-program switching frequency if needed, . The switching frequency is preset to 500KHz on this board. Please note that an external bootstrap diode from 5Vsupply to BST pin is necessary to boost gate drive voltage if switching frequency is above 2MHz because the charge time is reduced at high switching frequency.
8. Use R4, R6 to set output voltage,  $V_{fb}=0.8V$ . For  $R4= 40.2k\Omega$ , R6 can be determined by:  $R6 = 50.25 \times (V_{out} (V) - 0.8)(k\Omega)$ . Please follow the application information on the datasheet to recalculate/or select compensation values, inductor value, and output capacitor value when the Vout is changed.

**NOTICE:** The information in this document is subject to change without notice. Users should warrant and guarantee that third party Intellectual Property rights are not infringed upon when integrating MPS products into any application. MPS will not assume any legal responsibility for any said applications.

# Mouser Electronics

Authorized Distributor

Click to View Pricing, Inventory, Delivery & Lifecycle Information:

[Monolithic Power Systems \(MPS\):](#)

[EV4462DQ-00B](#)