

---

**LF Wake-up Demonstrator ATAK5279-82 Using Six-fold  
Antenna Driver ATA5279**

---

**ATAK5279-82****General Description**

---

The demonstrator is intended to show LF wake-up functionality using the new six-fold LF antenna driver ATA5279 and the 3D receiver Atmel® ATA5282. The demonstrator may also be helpful for studying systems or as a reference tool for target applications.

Typical wake-up applications are designed in vehicles for Passive Entry (PE) and Tire Pressure Monitoring (TPMS).

The high antenna driver ability of the transmitter as well as the sensitive receiver enable a wake-up distance of up to three meters.

Please be noted that Atmel ATA5282 and Atmel ATA5283 have been discontinued. These devices are just used here for demonstration purpose.

# 1. System Overview

Figure 1-1. LF Wake-up Demonstration System



## 1.1 Components Included in the LF Wake-up Demonstrator

- ATAB-LFMB-79 microcontroller base board
- ATAB5279 six-fold antenna driver board
- ATAB5282 3D indicator board including 3V lithium battery (optional ATAB5283 1D indicator)
- Two antenna modules ATAB-LFTX-V2.0
- Interface cable RS232
- Two cables for DC power supply
- CD-ROM with installation software and documentation

## 1.2 Equipment Needed

- Host PC running Windows® 95 or higher, with CD-ROM drive
- 8V to 15V DC 2A power supply

## 2. Hardware Components

The ATAB5279 driver board is patched onto the microcontroller baseboard ATAB-LFMB-79. The mounted AVR® microcontroller ATmega8515 is programmed by C-language to control the antenna driver and to maintain communication with the host. Operating software, provided on the CD, must be installed on the host. A power source with a voltage range of 8V to 15V/2A is needed to supply, in parallel, the baseboard and the driver board with separate cable connectors. See [Figure 1-1 on page 2](#) and [Figure 2-1](#).

**Figure 2-1. Components Contained in Kit**

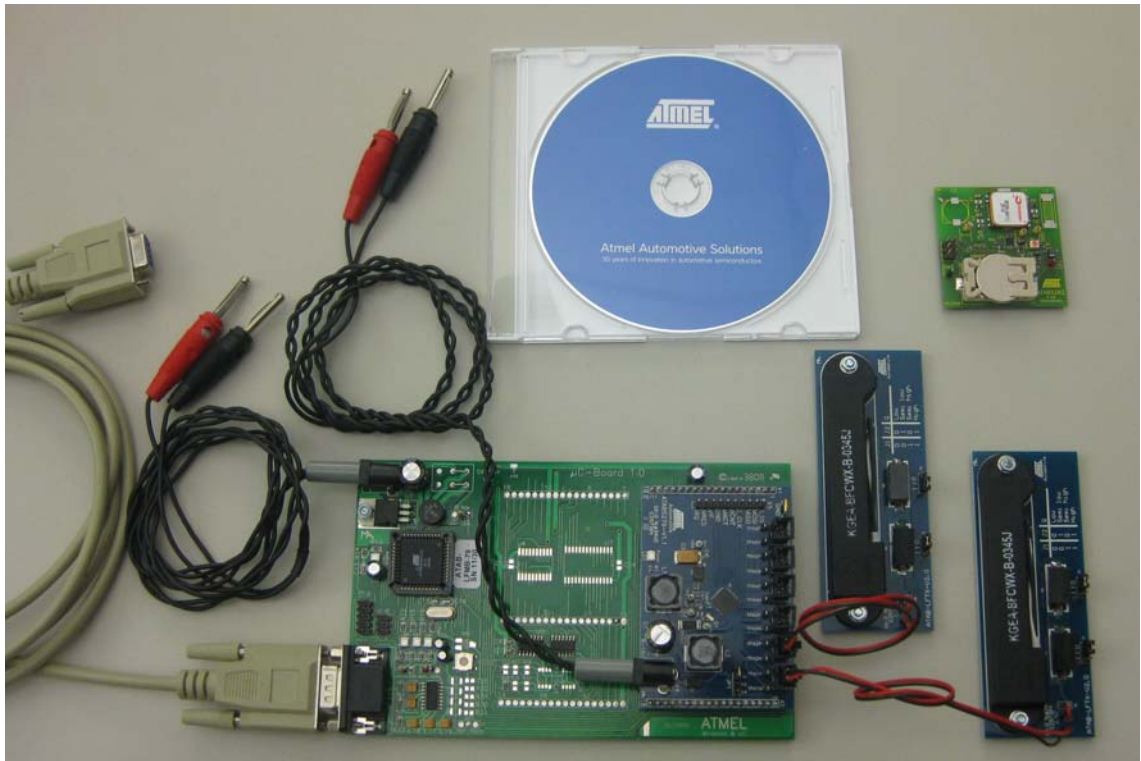

## 2.1 Six Fold Antenna Driver Board ATAB5279

The driver board is plugged onto the baseboard by dual line header pin connectors. Data communication between the boards is achieved via the integrated SPI interface of AVR and driver IC.

The driver board is equipped with:

- Screwless connectors for connecting six LF antenna modules
- Boost converter choke generating the driver voltage to track the antenna current regulation independent of battery voltage and antenna impedance
- 8MHz resonator oscillator generating a fixed antenna driver frequency of 125kHz

**Figure 2-2. Antenna Driver Board ATAB5279-V1.1**

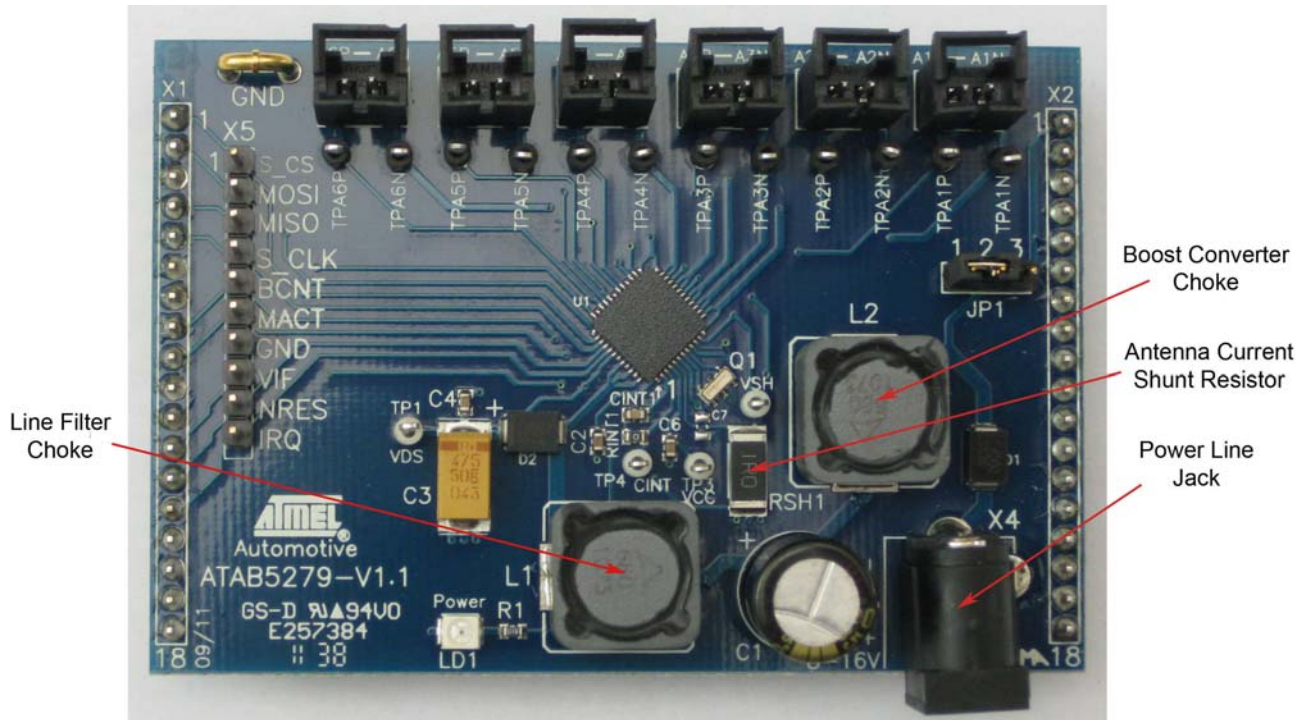
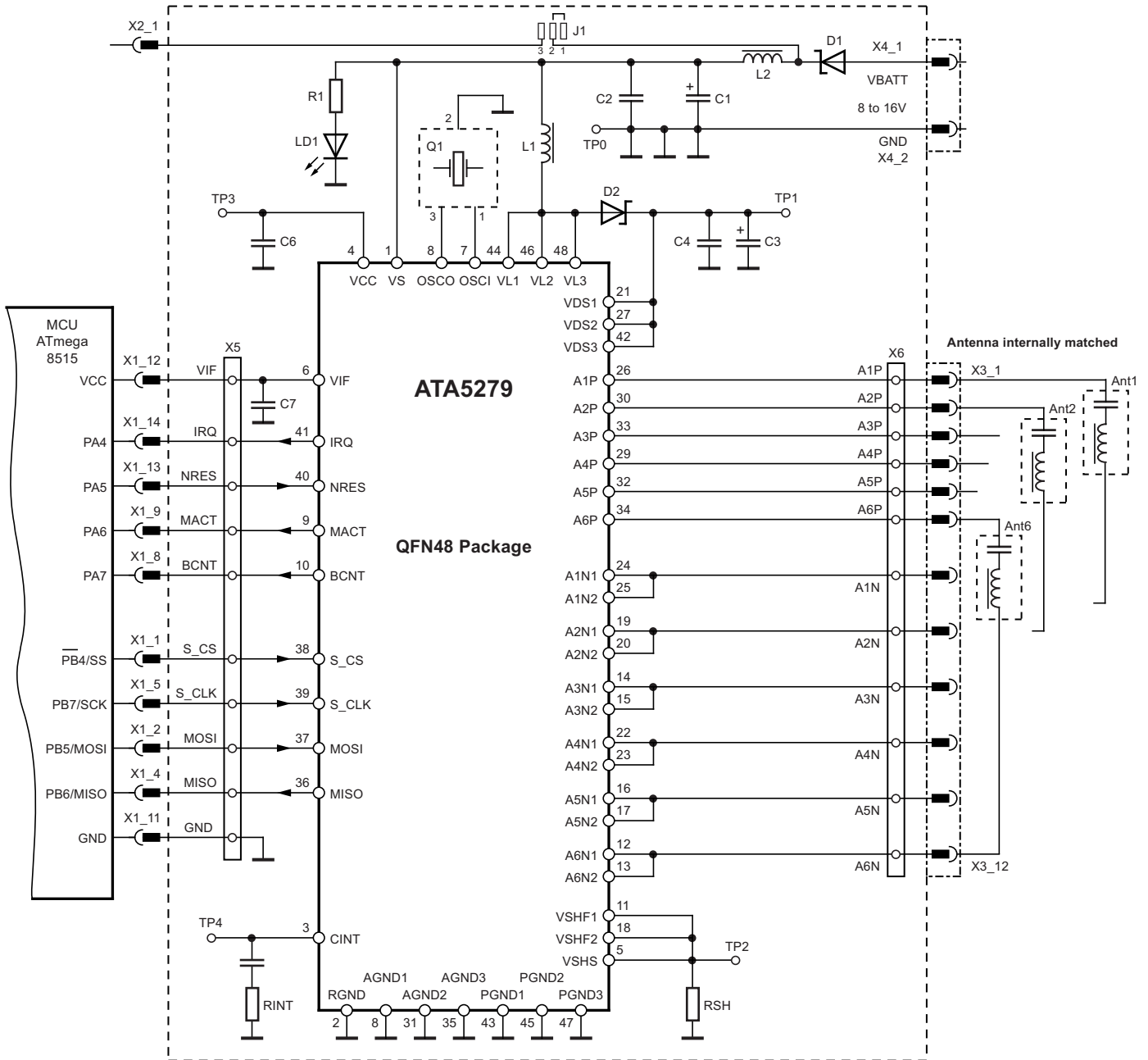

Figure 2-3. Schematic of the Antenna Driver Transmitter Board ATAB5279\_V1.1



**Table 2-1. Part List of the Antenna Driver Board ATAB5279\_V1.1**

Part No.	Designation	Value	Type	Manufacturer (Distributor)
U1	Transmitter IC		ATA5279	Atmel®
D1	Diode	Schottky 60V/2A	SS26	Vishay®
D2	Diode	Schottky 60V/2A	SS26	Vishay
LD1	LED	Red	TLMT 3100	e.g., Vishay
R1	Resistor	1.8kΩ	SMD 0603	
RSH	Resistor	1.0Ω/1W	SMD 3520 224-0008	e.g., RS
RINT	Resistor	0Ω		
C1	Capacitor	Electrolytic 220µF/35V	EEUFM1V221 (526-1828)	Panasonic® (RS)
C2	Capacitor	Ceramic 100nF	SMD 0603	Standard
C3	Capacitor	Ceramic 10µF/50V	GCM32EC71H106K	Murata®
C4	Capacitor	Ceramic 100nF	SMD 0603	Standard
C6	Capacitor	Ceramic 100nF	SMD 0603	Standard
C7	Capacitor	Ceramic 100nF	SMD 0603	Standard
CINT	Capacitor	Ceramic 10nF	SMD 0603	Standard
L1	Inductor	68µH/2.45A/98mΩ	B82477P4683M00/ Alternative 744 770 168	EPCOS/ Würth Elektronik
L2	Inductor	68µH/2.45A/98mΩ	B82477P4683M00/ Alternative 744 770 168	EPCOS/ Würth Elektronik
Q1	Resonator	8MHz	CSTCE8M00G52A-R0	Murata
X1-X2	Header pin	18 pin (solder)	1001-171-018	e.g., CAB
XAnt1-6	Ant. connector	(Tyco 5-103669-1)	Or.Nr.: A33893-ND	e.g., DigiKey
X4	Power Plug		486-662	e.g., RS
X5	Header Pin	10 pin inline (Component)	1001-171-010	e.g., CAB
TP1-TP4	PCB test terminal	White	262-2040	e.g., RS
TPA1P-TPA6P	PCB test terminal	Black	262-2179	e.g., RS
TPA1N-TPA6N	PCB test terminal	Black	262-2179	e.g., RS
JP1	Header Pin	3 pin inline (RM2.54mm)	1001-171-003	e.g., CAB
(JP1)	Jumper	2.54mm	3300111	e.g., CAB
GND	Ground shackle	Pitch 5.08: d = 1mm	13.07.056	Ettinger
PCB	Interface	ATAB5279-V1.1	1.5mm, FR4, blue/white	Wagner

## 2.2 Antenna Module ATAB-LFTX-V2.0

The module is equipped with an integrated standard antenna internally matched to a typical resonant frequency of 125kHz. On board there are two series resistors enabling 4 antenna quality factor values selectable by jumper JP1 and JP2.

Figure 2-4. Antenna Module ATAB-LFTX-V2.0



### Typical Antenna Coil Parameters at 125kHz (type Premo KGEA-BFCWX-B-0345J):

Antenna Coil Inductance	LC = 345 [μH] ±5%
Antenna Coil Resistance	RC = 2.3Ω
Series Resistors	R1 = 10Ω/5W
Series Resistors	R2 = 6.8Ω/5W

Table 2-2. Selectable Q-factor

Jumper J1	0	1	0	1
Jumper J2	0	1	0	1
Series Resistance RT (Ω)	19.1	12.3	9.1	2.3
Antenna Q Factor	14.2	22.0	29.8	117.8

Table 2-3. Alternative Antennas on Market (Datasheet Values)

Supplier	Part Number	Inductance at 125kHz	Resonant Frequenc	Q Factor	Resistance at 125 kHz	Capacitor Internal
TOKO	STA8121-0002	-	125kHz ±1%	-	1.8Ω	4.7nF
Premo	KGEA-BFCWX-B-0345G	345μH	125kHz ±2%	>115	-	4.7nF

## 2.3 Indicator Board ATAB5282 (Optional)

On the receiver side, the three-channel LF receiver board ATAB5282 is preferred for passive entry (PE) applications. It is equipped with a 3D antenna specified with a sensitivity in all directions of approximately 100mV/Am. To guarantee a data rate of 4kbit/s for header detection, the total Q factor of the antenna coils is adjusted to about 25 via parallel resistors. This receiver configuration combined with the antenna module driven with the maximal driver current of 1Ap, achieves a wake-up distance of at least two meters in all directions. The board also enables an optional assembly by separate antenna coils for x,y,z field detection. In addition, an LED is used to indicate the received data protocol. Test points and a pin socket allow the measurement of the relevant signals. The RSSI measurement must be performed by an external control unit connecting NWAKE and NSCL via 6-pin header.

A 3V-lithium battery is used to supply the receiver's LEDs.

**Figure 2-5. Indicator Board ATAB5282V4**





**Figure 2-6. Schematic of Indicator Board ATAB5282V4**

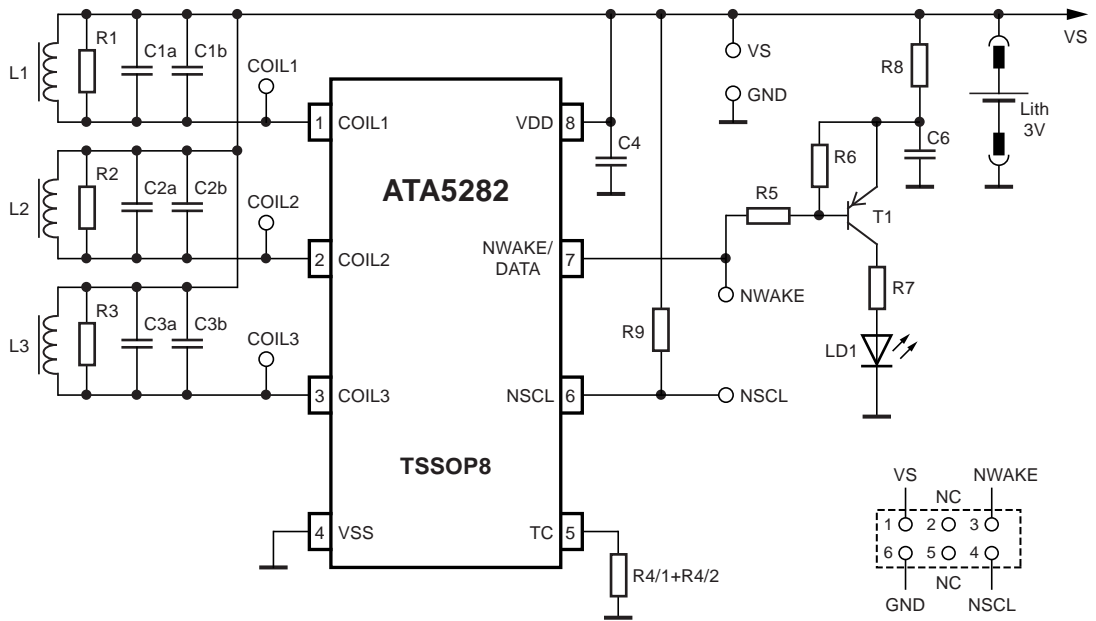

**Table 2-4. Part List of the Indicator Board ATA5282\_V4**

Part No.	Designation	Value	Type	Manufacturer
U1	Wake-up IC		T5282	Atmel
T1	Transistor	PNP	BC857	
LD1	LED	Red	TLMT3100	Vishay
L1-(L3)	3D Antenna Coil	4.77mH/7.20mH/Q = 23/29	3DC1515S-0477X P-749 002	Predan
C1	Capacitor	330pF ±5%/50V	SMD Ceramic	e.g., Vishay
C2	Capacitor	330pF ±5%/50V	SMD Ceramic	e.g., Vishay
C3	Capacitor	270pF ±5%/50V	SMD Ceramic	e.g., Vishay
C4	Capacitor	1µF/10V	Tantal	e.g., Vishay
C6	Capacitor	10µF/10V	Tantal	e.g. Vishay
R1	Resistor	180kΩ	SMD 0805	
R2	Resistor	180kΩ	SMD 0805	
R3	Resistor	390kΩ	SMD 0805	
R4/1	Resistor	1MΩ	SMD 0805	
R4/2	Resistor	1MΩ	SMD 0805	
R5	Resistor	47kΩ	SMD 0805	
R6	Resistor	100kΩ	SMD 0805	
R7	Resistor	100Ω	SMD 0805	
R8	Resistor	100Ω	SMD 0805	
R9	Resistor	10kΩ	SMD 0805	
Vbatt1	Battery Holder		MPD BA2032SM	MPD Inc.
Li-Cell		3V/220mAh	CR2032	
7 pcs	Test Pins			
1 pcs	Test Socket	2 x 3 pole		

## 2.4 Receiver Board ATAB5283

The board, mainly preferred for TPMS applications, is equipped with a 1D LF antenna. A parallel resistor to the antenna coil is used to adapt the data rate, even though there is no header by the IC.

Received data is indicated by an LED display. When the IC wakes up, it remains in active mode until a Reset is executed to initialize standby mode again.

Test pins allow the measurement of all relevant signals. A 3V lithium battery is used to supply the receiver's LEDs.

Figure 2-7. Indicator Board ATAB5283V3

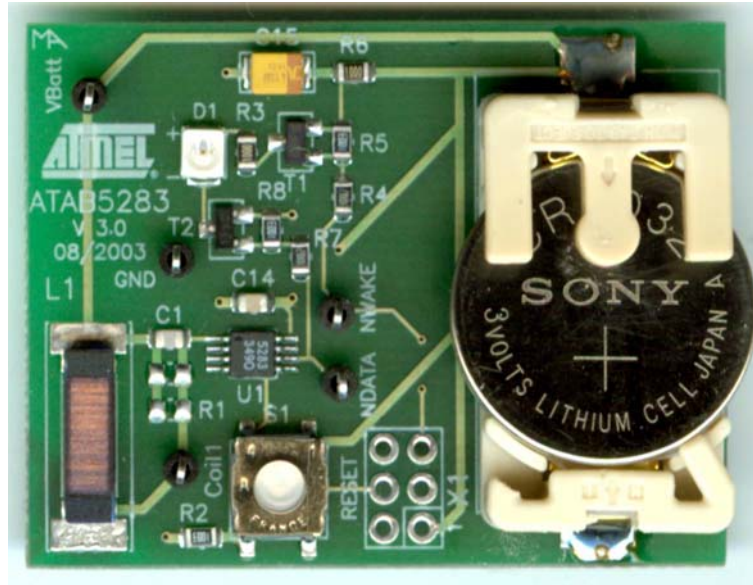
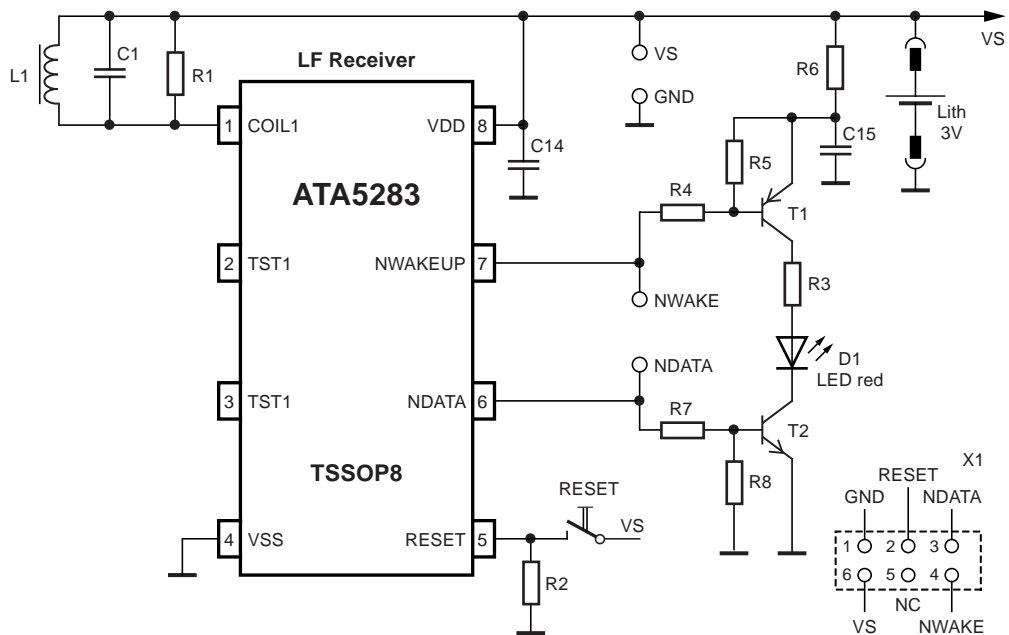

Figure 2-8. Schematic of Indicator Board ATAB5283V3



**Table 2-5. Part List of Receiver Board ATAB5283\_V3**

Part No.	Designation	Value	Type	Supplier
U1	Wake-up IC		T5283	Atmel
T1	Transistor	PNP	BC857	
T2	Transistor	NPN	BC847	
D1	LED	Red	TLMT3100	Vishay
L1	Antenna Coil	7.2mH/Q = 28	SDTR 1103-0720J	Predan
C1	Capacitor	220pF ±5%/50V	SMD Ceramic	e.g., Vishay
C1b	Capacitor	Option		e.g., Vishay
C14	Capacitor	100nF ±10%/50V	SMD Ceramic	e.g., Vishay
C15	Capacitor	10µF/10V	Tantal	e.g., Vishay
R1	Resistor	Option		
R2	Resistor	100kΩ		
R3	Resistor	100Ω		
R4	Resistor	47kΩ		
R5	Resistor	100kΩ		
R6	Resistor	100Ω		
R7	Resistor	10kΩ		
R8	Resistor	100kΩ		
Vbatt1	Battery holder		MPD BA2032SM	MPD Inc.
Li-Cell		3V/220mAh	CR2032	
S1	Taster			ITT-Cannon®
6 pcs	Test Pins			
1 pcs	Test Socket	2 x 3 pole		

### 3. Host Software

The Graphical User Interface (GUI), written in Visual Basic V7.0, is used to communicate with the AVR microcontroller on the base board.

The software is installed using a self-extracting setup file contained on the CD-ROM (see [Section 4. "Starting the Demonstrator" on page 16](#)).

When installed, the operating menu is displayed (see [Figure 3-1](#)).

**Figure 3-1. Operating Menu on Host**

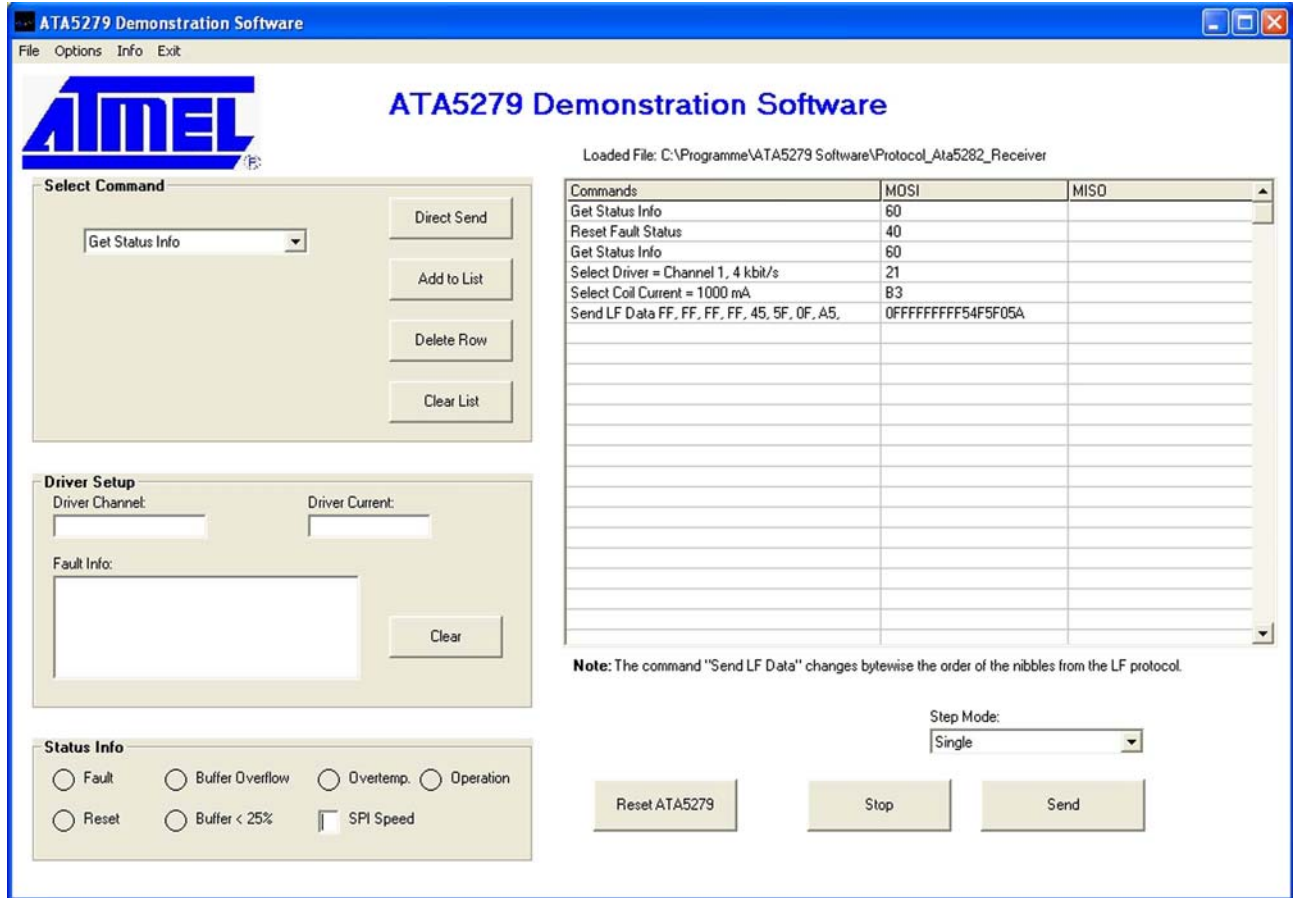

All commands and status information can be sent and read to and from the driver IC using the menu commands.

### 3.1 Command Selection

Commands accepted by the ATA5279 can be selected from the drop-down menu in the "Select Command" area (see [Figure 3-2](#)). The selected command can be sent directly to the IC by clicking the Direct Send button. Alternatively, click the Add to List button to create a command sequence as shown by [Figure 3-1 on page 12](#). Using the Add to List and Clear Row button, the command sequence can be modified.

Figure 3-2. Command Selection



### 3.2 Step Mode

Before sending commands to the ATA5279, the manner in which the commands are sent can be configured via the Step Mode drop-down list (see [Figure 3-3](#)). Commands can be sent step-wise in single steps or using an Auto step mode with a pre-selected step delay time. Command sequences can be saved or loaded via the File menu.

Figure 3-3. Auto Step Mode

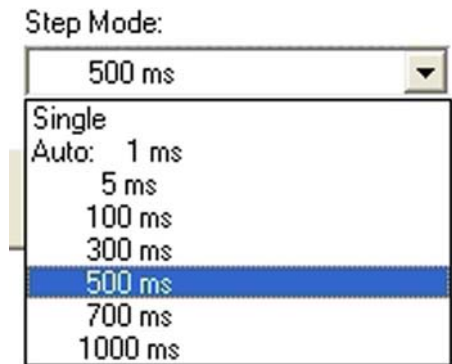

### 3.3 Status Monitoring

The "Driver Setup" area provides information about the selected driver channel number as well as about the set-point of the driver current. The Get Diver Setup command has to be sent to refresh the information displayed.

The "Status Info" area provides information about the general IC status. The Fault flag signals a common failure by interrupt request IRQ line. The special source of interrupt is decoded via the fault register.

An explicit indication is given for over-temperature or if an overflow or underflow of the data buffer occurs. The Get Status Info command must be sent to refresh the information displayed.

A Get Fault Info command has to be sent to indicate the type of fault. A message relating to the fault is displayed in the "Fault Info" text box.

**Figure 3-4. Status Monitoring**

### 3.4 Creating LF Data to be Sent

If the Send LD Data command is selected from the Select Command drop-down list, a number of new fields are displayed, see [Figure 3-5](#). The nipple number can be selected from a drop-down list. The nipple sending order can be specified using the text boxes. The upper left text box is the first nipple, and the lower right box the last. Each bit of a nipple represents a field on time duration of 128  $\mu$ s relating to a LF data rate of 4 kbit/s.

**Figure 3-5. LF Data Creation**

If the data is more than 16 nipples, an additional Send LF Data commands need to be sent. However, due to the transmission time via the serial interface, the internal data buffer of the ATA5279 cannot be recharged fast enough which leads to an interruption of the sent LF data sequence.

A longer term of non interrupted LF data pattern is only possible if the data buffer is reloaded from the firmware of the microcontroller. A special run mode feature will be implemented in a later software version.

### 3.5 Command Code Structure

The host software uses a text interpreter to convert the selected ASCII commands into the corresponding byte value to be sent to the AT5279 IC via MOSI line of the SPI interface. For each MOSI command, the IC responds to the last received command byte value by MISO line.

If a status command is sent, an additional byte follows containing the status value (see [Figure 3-5 on page 14](#)).

Note, for the "Send LF Data" command, the order of the LF data nipples is byte-wise inverted in relation to the MOSI command. That is a special feature of this host software to make it easier for users to create their own LF data pattern.

An example of a command sequence extract is shown in [Figure 3-6 on page 15](#).

**Figure 3-6. Example of Command Code**

Loaded File: C:\Programme\ATA5279 Software\Protocol\_Channel\_1-6

Commands	MOSI	MISO
Select Driver = Channel 1, 4 kbit/s	21	40
Select Coil Current = 500 mA	A9	21
Get Driver Setup	68	A949
Send LF Data FF, FF, FF, FF, 45, 5F, 0F, A5,	0FFFFFFF54F5F05A	680FFFFFFF54F5F0
Get Status Info	60	5A40
Get Fault Info	70	6028

## 4. Starting the Demonstrator

1. Install the demonstration software by running the setup.exe file and following the menu instructions. If, during the installation process the proposed default folder is accepted, the path of the ATA5279.exe is as follows:  
Using an English-language Windows system:\Program Files\Ata5279 Software\Ata5279.exe  
Using a German-language Windows system:\Programme\ Ata5279 Software\Ata5279.exe
2. Copy the default LF data "Protocol\_ATA5282\_Receiver" and "Protocol\_Channel\_1-6" from the CD ROM to the installation folder.
3. When the software program Atab5279.exe (located in the installation folder) has been installed, the host operating menu appears as shown in [Figure 3-1 on page 12](#).
4. Build up the demonstrator system according to the configuration shown in [Figure 1-1 on page 2](#) and [Figure 2-1 on page 3](#).

Note: For software installation, ensure the host PC has "write" permission.

### 4.1 Waking-up the ATA5282 Indicator

1. Insert the battery into the slot on the ATAB5282 receiver board and place the board at a distance of about 50cm along the transmitter antenna axis.
2. Load on host menu the "Protocol\_At5282\_Receiver" file prepared to pass the header detection of the receiver.
3. The related LF data is sent by the driver channel no.1 with 4kbit/s and an antenna current of 1000mA.

Figure 4-1. ATAB5282 Receiver Board

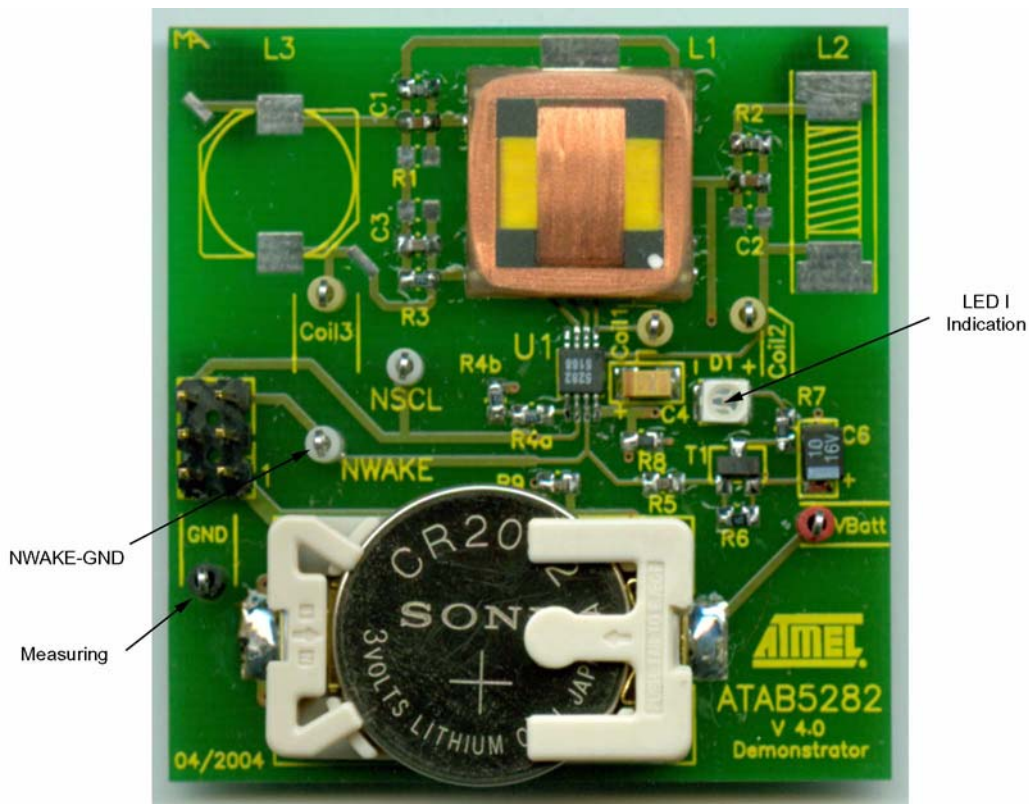



Figure 4-2. File Load



Figure 4-3. ATA5282 Protocol

Loaded File: C:\Programme\ATA5279 Software\Protocol\_At5282\_Receiver

Commands	MOSI
Get Status Info	60
Reset Fault Status	40
Get Status Info	60
Select Driver = Channel 1, 4 kbit/s	21
Select Coil Current = 1000 mA	B3
Send LF Data FF, FF, FF, FF, 45, 5F, 0F, A5	0FFFFFFF54F5F05A

4. Select Step Mode > Auto = 500 ms from the Step Mode drop-down menu (see [Figure 3-3 on page 13](#)) and click the Send button.
5. The command sequence shown in [Figure 4-3](#) is sent in loop. Each time the Send LF data is executed, the LED on the ATAB5282 board flashes (see LED I Indication in [Figure 4-1](#)).
6. While the LF data is being sent in Auto Step mode, move the receiver along the distance and orientation to check the receive performance. With an antenna current of 1000 mA the receiver should be able to detect the sent protocol at a distance of at least 2 meters.

## 4.2 Signal Transmission Tx-Rx Measurement

During the wake-up procedure described in [Section 4.1 "Waking-up the ATA5282 Indicator" on page 16](#), the LF data transmission signals between the antenna driver board ATAB5279 and receiver board ATAB5282 can also be measured. Connect an oscilloscope to the test pins on the boards.

Figure 4-4. Signal Measurement

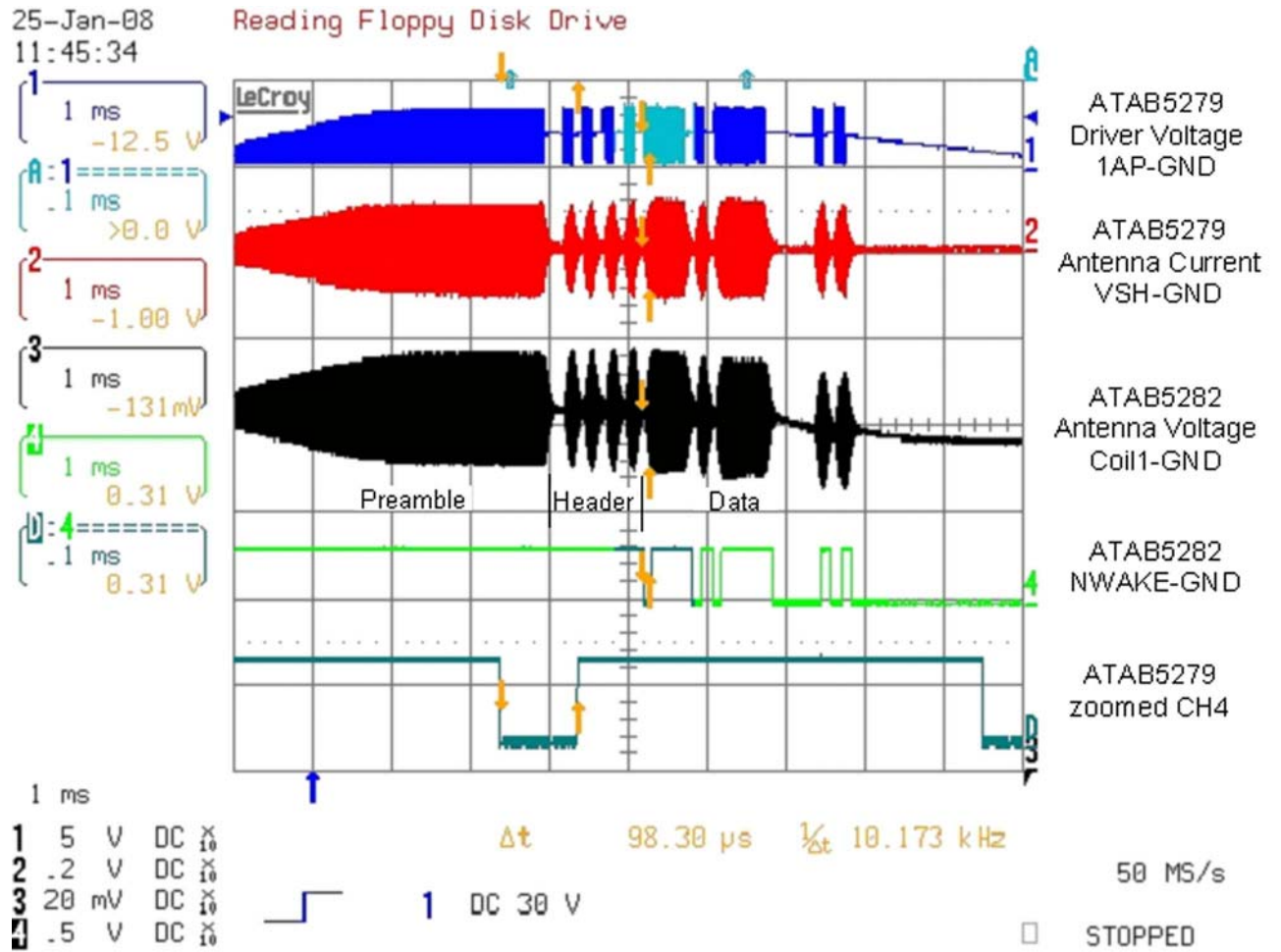

### 4.3 Diagnostic Functions

The IC protects itself from destruction if a fault occurs. For demonstration purposes, an antenna fault can be provoked. The result can be seen in the Status Info and Fault Info fields.

- Configure driver channel as follows:
  - Channel AP1-AN1 > antenna module
  - Channel AP2-AN2 > antenna module
  - Channel AP3-AN3 > short circuit
  - Channel AP4-GND > short circuit
  - Channel AP5-Vbatt > short circuit
  - Channel AN6-Vbatt > short circuit
- Load by File tap Protocol\_Channel\_1-6
- Send commands in Single Step Mode and watch the Status Info indication and Fault Info message according to [Figure 3-4 on page 14](#) after activation of each channel.

**Figure 4-5. Channel Diagnostic**

Loaded File: C:\Programme\ATA5279 Software\Protocol\_Channel\_1-6

Commands	MOSI
Select Driver = Channel 1, 4 kbit/s	21
Select Coil Current = 500 mA	A9
Get Driver Setup	68
Send LF Data FF, FF, FF, FF, 45, 5F, 0F, A5,	0FFFFFFFFF54F5F05A
Get Status Info	60
Get Fault Info	70
Reset Fault Status	40
Get Status Info	60

## 5. Revision History

Please note that the following page numbers referred to in this section refer to the specific revision mentioned, not to this document.

Revision No.	History
9124F-AUTO-04/15	• Put document in the latest template
9124E-AUTO-02/13	• Table 2-1 “Part List of the Antenna Driver Board ATAB5279_V1.1” on page 6 updated
9124D-AUTO-12/12	• Section 2.2 “Antenna Module ATAB-LFTX-V2.0” on page 7 updated
9124C-AUTO-09/12	• Section 2.2 “Antenna Module ATAB-LFTX-V2.0” on page 7 updated



**Atmel Corporation** 1600 Technology Drive, San Jose, CA 95110 USA T: (+1)(408) 441.0311 F: (+1)(408) 436.4200 | [www.atmel.com](http://www.atmel.com)

© 2015 Atmel Corporation. / Rev.: 9124F–AUTO–04/15

Atmel®, Atmel logo and combinations thereof, Enabling Unlimited Possibilities®, AVR®, and others are registered trademarks or trademarks of Atmel Corporation in U.S. and other countries. Other terms and product names may be trademarks of others.

DISCLAIMER: The information in this document is provided in connection with Atmel products. No license, express or implied, by estoppel or otherwise, to any intellectual property right is granted by this document or in connection with the sale of Atmel products. EXCEPT AS SET FORTH IN THE ATMEL TERMS AND CONDITIONS OF SALES LOCATED ON THE ATMEL WEBSITE, ATMEL ASSUMES NO LIABILITY WHATSOEVER AND DISCLAIMS ANY EXPRESS, IMPLIED OR STATUTORY WARRANTY RELATING TO ITS PRODUCTS INCLUDING, BUT NOT LIMITED TO, THE IMPLIED WARRANTY OF MERCHANTABILITY, FITNESS FOR A PARTICULAR PURPOSE, OR NON-INFRINGEMENT. IN NO EVENT SHALL ATMEL BE LIABLE FOR ANY DIRECT, INDIRECT, CONSEQUENTIAL, PUNITIVE, SPECIAL OR INCIDENTAL DAMAGES (INCLUDING, WITHOUT LIMITATION, DAMAGES FOR LOSS AND PROFITS, BUSINESS INTERRUPTION, OR LOSS OF INFORMATION) ARISING OUT OF THE USE OR INABILITY TO USE THIS DOCUMENT, EVEN IF ATMEL HAS BEEN ADVISED OF THE POSSIBILITY OF SUCH DAMAGES. Atmel makes no representations or warranties with respect to the accuracy or completeness of the contents of this document and reserves the right to make changes to specifications and products descriptions at any time without notice. Atmel does not make any commitment to update the information contained herein. Unless specifically provided otherwise, Atmel products are not suitable for, and shall not be used in, automotive applications. Atmel products are not intended, authorized, or warranted for use as components in applications intended to support or sustain life.

SAFETY-CRITICAL, MILITARY, AND AUTOMOTIVE APPLICATIONS DISCLAIMER: Atmel products are not designed for and will not be used in connection with any applications where the failure of such products would reasonably be expected to result in significant personal injury or death ("Safety-Critical Applications") without an Atmel officer's specific written consent. Safety-Critical Applications include, without limitation, life support devices and systems, equipment or systems for the operation of nuclear facilities and weapons systems. Atmel products are not designed nor intended for use in military or aerospace applications or environments unless specifically designated by Atmel as military-grade. Atmel products are not designed nor intended for use in automotive applications unless specifically designated by Atmel as automotive-grade.

# Mouser Electronics

Authorized Distributor

Click to View Pricing, Inventory, Delivery & Lifecycle Information:

[Microchip:](#)

[ATAB-LFTX-MOD1](#) [ATAB5279](#)