

391 Series, TE5® Fast-Acting Fuse

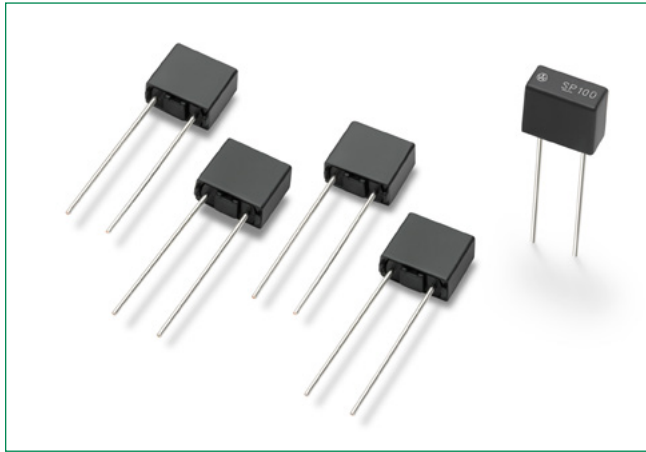

Description

The 391 Series are TE5® short circuit protector, fast-acting type, 65V rated fuses. For Short Circuit Protection of Sensitive Electronic Components and Assemblies.

Features

- Recognized to UL/CSA/ NMX 248-1 and UL/CSA/ NMX 248-14
- Reduced PCB space requirements
- Highly defined cut-off times
- Low internal resistance
- Flame resistant encapsulated casing
- RoHS-compliant and Lead-free
- Available from 0.125A to 4A.

Agency Approvals

Agency	Agency File Number	Ampere Range
	E67006	0.125A - 4A

Applications

- Battery chargers
- Consumer Electronics
- Power supplies
- Industrial controllers

Additional Information



Datasheet



Resources



Samples

Electrical Characteristics

% of Ampere Rating	Opening Time
300	2 Seconds, Max.

Electrical Characteristics

Amp Code	Rated Current	Marking Code*	Voltage Rating	Breaking Capacity	Nominal Cold Resistance (Ohms)	Cold Resistance 0.1xI _N max. (mΩ)	Power Dissipation 1.0xI _N max. (mW)	Melting Integral 10xI _N max. (A ² s)	Agency Approvals
0125	125 mA	SP13	65 V	50A @65VAC/DCC	3.4000	3400	190	0.006	x
0160	160 mA	SP16	65 V		2.4800	2450	210	0.011	x
0200	200 mA	SP20	65 V		1.7500	1750	240	0.020	x
0250	250 mA	SP25	65 V		0.1950	195	52	0.012	x
0315	315 mA	SP32	65 V		0.1850	155	65	0.018	x
0400	400 mA	SP40	65 V		0.1200	120	85	0.038	x
0500	500 mA	SP50	65 V		0.0950	95	105	0.063	x
0630	630 mA	SP63	65 V		0.0750	75	135	0.105	x
0800	800 mA	SP80	65 V		0.0580	58	170	0.170	x
1100	1.00 A	SP100	65 V		0.0460	46	220	0.280	x
1125	1.25 A	SP125	65 V		0.0370	37	270	0.450	x
1160	1.60 A	SP160	65 V		0.0290	29	350	0.832	x
1200	2.00 A	SP200	65 V		0.0236	23	440	1.060	x
1250	2.50 A	SP250	65 V		0.0180	18	550	2.219	x
1315	3.15 A	SP315	65 V		0.0140	14	700	3.870	x
1400	4.00 A	SP400	65 V		0.0115	12	900	6.500	x

Notes:

- * Physical Marking on top of the device.
- Resistance is measured at 10% of rated current, 25°C.

Temperature Re-rating Curve

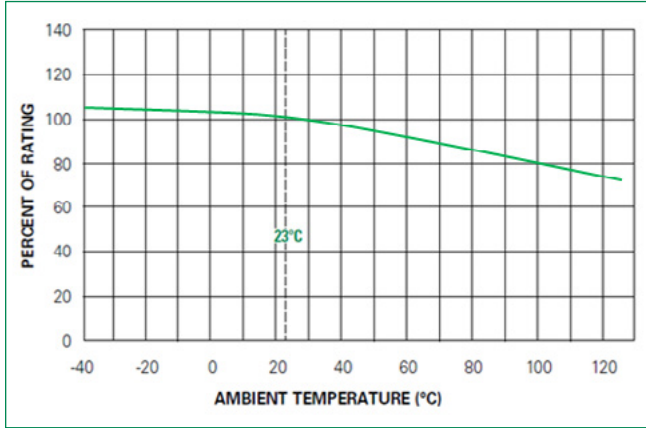

Note:
1. Rerating depicted in this curve is in addition to the standard derating of 25% for continuous operation.

Average Time Current Curves

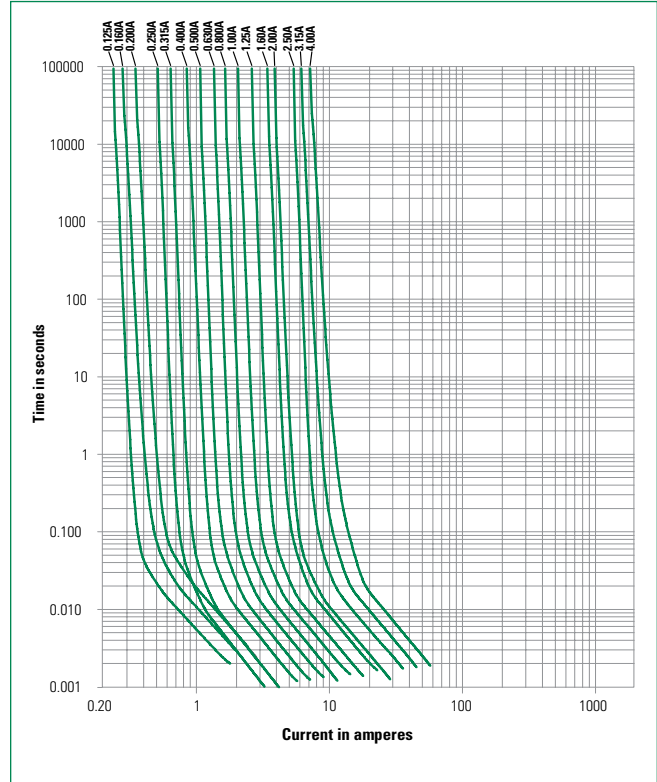

Soldering Parameters - Wave Soldering

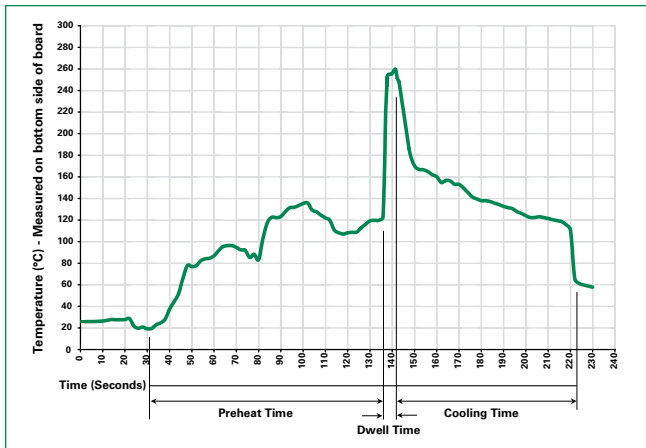

Recommended Process Parameters:

Wave Parameter	Lead-Free Recommendation
Preheat: (Depends on Flux Activation Temperature)	(Typical Industry Recommendation)
Temperature Minimum:	100° C
Temperature Maximum:	150° C
Preheat Time:	60-180 seconds
Solder Pot Temperature:	260° C Maximum
Solder Dwell Time:	2-5 seconds

Recommended Hand-Solder Parameters:

Solder Iron Temperature: 350° C +/- 5° C
Heating Time: 5 seconds max.

Note: These devices are not recommended for IR or Convection Reflow process.

Product Characteristics

Materials	Base/Cap: Thermoplastic Polyamide PA 6.6, UL 94V-0 Round Pins: Copper, Tin-plated
Lead Pull Strength	10 N (EN 60068-2-21)
Solderability	260°C, ≤ 3s. (Wave) 350°C, ≤ 1s. (Soldering Iron)
Soldering Heat Resistance	260°C, 10s. (IEC 60068-2-20) 350°C, 3s. (Soldering Iron)

Operating Temperature	-40°C to +125°C (consider re-rating)
Climatic Category	-40°C to +85°C/21 days (IEC 60068-1,-2-1,-2-2,-78)
Stock Conditions	+10 °C to +60 °C RH, ≤ 75% yearly average, without dew, maximum value for 30 days-95%
Vibration Resistance	24 cycles at 15 min. each (IEC 60068-2-6) 10 - 60 Hz at 0.75 mm amplitude 60 - 2000 Hz at 10 g acceleration

Dimensions

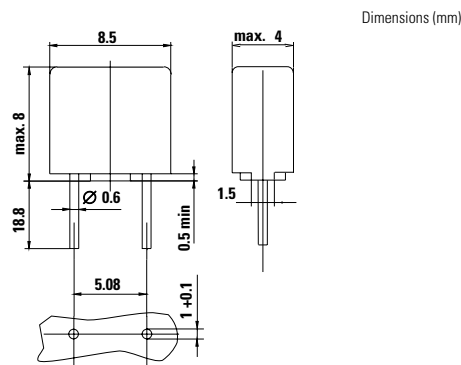

Part Numbering System

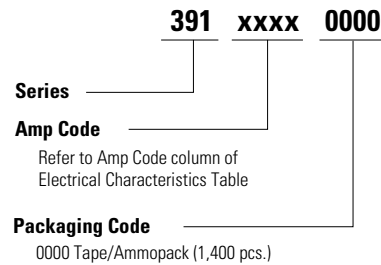

Packaging

Packaging Option	Packaging Specification	Quantity	Quantity & Packaging Code	Taping Width
391 Series				
Tape & Ampopack	N/A	1,400	0000	N/A

Disclaimer Notice - Littelfuse products are not designed for, and shall not be used for, any purpose (including, without limitation, automotive, military, aerospace, medical, life-saving, life-sustaining or nuclear facility applications, devices intended for surgical implant into the body, or any other application in which the failure or lack of desired operation of the product may result in personal injury, death, or property damage) other than those expressly set forth in applicable Littelfuse product documentation. Warranties granted by Littelfuse shall be deemed void for products used for any purpose not expressly set forth in applicable Littelfuse documentation. Littelfuse shall not be liable for any claims or damages arising out of products used in applications not expressly intended by Littelfuse as set forth in applicable Littelfuse documentation. The sale and use of Littelfuse products is subject to Littelfuse Terms and Conditions of Sale, unless otherwise agreed by Littelfuse. Information furnished is believed to be accurate and reliable. However, users should independently evaluate the suitability of and test each product selected for their own applications. Littelfuse products are not designed for, and may not be used in, all applications. Read complete Disclaimer Notice at www.littelfuse.com/disclaimer-electronics.

Mouser Electronics

Authorized Distributor

Click to View Pricing, Inventory, Delivery & Lifecycle Information:

Littelfuse:

[39111000000](#) [39114000000](#) [39112000000](#) [39105000000](#) [39102000000](#) [39104000000](#) [39106300000](#)
[39108000000](#) [39102500000](#) [39112500000](#) [39102500000](#) [39101600000](#) [39111600000](#) [39111250000](#) [39106300000](#)
[39111250000](#) [39101250000](#) [39111600000](#) [39101600000](#) [39103150000](#) [39113150000](#) [39102000000](#) [39101250000](#)
[39105000000](#) [39104000000](#) [39108000000](#) [39112500000](#) [39111000000](#) [39112000000](#) [39103150000](#)