

Datasheet

BT800

Bluetooth v4.0 Dual-Mode USB HCI Module

Version 2.3

REVISION HISTORY

Version	Date	Notes	Approver
1.0	04 Sept 2013	Initial Release	Jonathan Kaye
1.1	23 Sept 2013	Updated Regulatory/Certification section	Jonathan Kaye
1.2	07 Oct 2013	Update BT SIG Approvals section Edited text in <i>Low-voltage VDD_RADIO Linear Regulator</i> section	Jonathan Kaye
1.3	04 Feb 2014	Added a SPI note where applicable: Note: The purpose of the SPI interface is to access the module's inner settings such as selecting different WLAN CO-EXIST scheme...	Jonathan Kaye
1.4	05 Feb 2014	Updated the Bluetooth SIG Approvals section.	Jonathan Kaye
1.5	16 July 2014	Updated Pin Definitions with "If Unconnected" information.	Jonathan Kaye
1.6	03 Dec 2014	Updated the Power Control and Regulation section.	Jonathan Kaye
1.7	25 March 2015	Updated document links	Sue White
1.8	28 April 2015	Removed MIC certification references	Sue White
1.9	10 Aug 2015	Added Tape/Reel packaging information	Jonathan Kaye
1.10	08 Sept 2015	Added MIC certification references	Sue White
1.11	15 Dec 2015	Replaced tray image with new one	Maggie Teng
2.0	06 July 2016	Changed from HIG to Datasheet Updates to <i>Power Control and Regulation</i> section	Andrew Chen
2.1	31 Aug 2016	Updated Declaration of Conformity	Sue White
2.2	05 May 2017	Updated Declaration of Conformity for RED	Tom Smith
2.3	15 Aug 2017	Added clarifier that BT820 HID Proxy only pairs with "Just Works" pairing and cannot pair to devices that require a pincode or passkey	Jonathan Kaye

CONTENTS

1	Scope	4
2	Operational Description	4
3	Block Diagram and Descriptions	5
4	Specifications	6
5	Pin Definitions	7
6	DC Electrical Characteristics	8
7	RF Characteristics	10
8	Interface	11
8.1.	PIO	11
8.2.	WLAN Coexistence Interface.....	11
8.3.	USB Interface.....	11
8.4.	PCM Interface.....	12
8.5.	GCI Interface.....	14
8.6.	Slots and Sample Formats	14
8.7.	PCM Timing Information	15
8.8.	PCM Slave Timing	17
8.9.	PCM Slave Mode Timing Parameters.....	17
8.10.	PCM_CLK and PCM_SYNC Generation	18
8.11.	PCM Configuration	19
8.12.	Digital Audio Interface (I ² S).....	19
9	Power Control and Regulation	22
9.1.	USB Linear Regulator.....	22
9.2.	High-voltage Linear Regulator.....	22
9.3.	Voltage Regulator Enable and Reset.....	23
9.4.	Power Sequencing.....	23
10	Antenna Performance	24
11	Mechanical Dimensions and Land Pattern	26
12	Implementation Note	27
12.1.	PCB Layout on Host PCB.....	27
13	Application Note for Surface Mount Modules	29
13.1.	Introduction.....	29
13.2.	Shipping	29
13.3.	Reflow Parameters	31
14	Japan (MIC) Regulatory	32
15	FCC and IC Regulatory	33
16	European Union Regulatory	35
17	Ordering Information	37
18	Bluetooth SIG Approvals.....	37
18.1.	Application Note: Subsystem Combinations.....	37
19	Additional Assistance.....	38

1 SCOPE

This document describes key hardware aspects of the Laird BT800 Bluetooth HCI/HID module. This document is intended to assist device manufacturers and related parties with the integration of this module into their host devices. Data in this document are drawn from a number of sources including data sheets for the CSR8510. Because the BT800 is currently in development stage, this document is preliminary and the information in this document is subject to change. Please contact Laird Technologies or visit the Laird website at www.lairdtech.com to obtain the most recent version of this document.

2 OPERATIONAL DESCRIPTION

The BT800 series of USB HCI devices are designed to meet the needs of OEMs adding robust Bluetooth connectivity and using embedded Bluetooth stacks within these products.

Leveraging the market-leading CSR8510 chipset, the BT800 series provides exceptionally low power consumption with outstanding range. Supporting the latest Bluetooth v4.0 Specification with EDR (Enhanced Data Rate), the Laird BT800 series enables OEMs to accelerate their development time for leveraging either Classic Bluetooth or Bluetooth Low Energy (BLE) into their operating system based devices.

With a tiny footprint as small as 8.5 x 13 mm, yet output power at 8 dBm, these modules are ideal for applications where designers need high performance in minimal size. For maximum flexibility in systems integration, the modules are designed to support a full speed USB interface plus GPIO and additionally I2S and PCM audio interfaces.

These modules present an HCI interface and have native support for Windows and Linux Bluetooth software stacks. All BT800 series devices are fully qualified as Bluetooth Controller Subsystem products. This also allows designers to integrate their existing pre-approved Bluetooth Host and Profile subsystem stacks to gain a Bluetooth END product approval for their products.

The BT800 series is engineered to provide excellent RF performance with integrated antenna and additional band pass filters. It further reduces regulatory and testing requirements for OEMs and ensures a hassle free development cycle. As an additional benefit of the BT800 series, Laird has implemented CSR's HID (Human Interface Device) Proxy Mode enabling out of the box HID connectivity for pointing devices and / or keyboard functionality, requiring zero host device software or configuration.



BT800 module



BT820 USB dongle

Note: On the BT820, HID Proxy mode works with “Just Works” devices and will not pair with BT devices that require a pincode or passkey.

A fully featured, low-cost developer's kit is available for prototyping, debug, and integration testing of the BT800 series modules and further reduces risk and time in development cycles.

Features and Benefit!

- Bluetooth v4.0 - Dual mode (Classic Bluetooth and BLE)
- Compact footprint
- 2-wire and 3-wire Wi-Fi coexistence scheme
- High antenna radiation gain and efficiency
- Good interference rejection for multi-com system (GSM/WCDMA)
- Class 1 output – 8 dBm
- USB, GPIO, I2S, and PCM
- Industrial Temperature Range
- 64 k EEPROM support for HID Proxy mode
- Bluetooth Controller subsystem
- FCC, IC, MIC, and CE approvals

Application Areas

- Medical devices
- ePOS terminals
- Barcode scanners
- Industrial Cable Replacement
- M2M Connectivity
- Automotive Diagnostic Equipment
- Personal Digital Assistants (PDA)
- Bluetooth HID device (keyboard, mouse, joystick)

3 BLOCK DIAGRAM AND DESCRIPTIONS

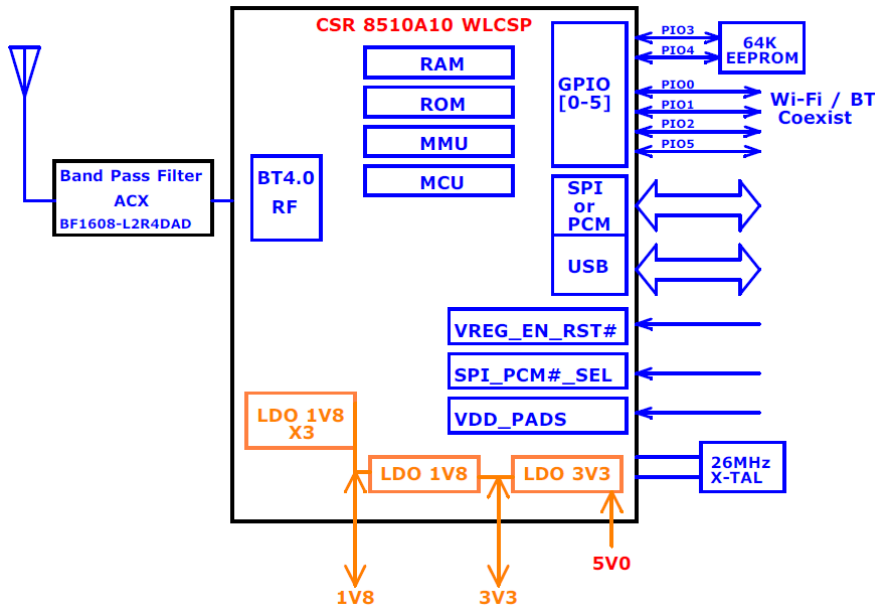

Figure 1: BT800 module block diagram

CS8510A10 (Main chip) The BT800 is based on CSR8510A10 dual mode chip. The chip is a single-chip radio with on-chip LDO regulators and baseband IC for Bluetooth 2.4 GHz systems including EDR to 3 Mbps. Dedicated signal and baseband processing is included for full Bluetooth operation. The chip provides SPI/PCM and USB interfaces. Up to four general purpose I/Os are available for general use such as Wi-Fi coexistence or general indicators.

Note: The purpose of the SPI interface is to access the module’s inner settings such as selecting different WLAN CO-EXIST scheme and enabling HID proxy mode. The SPI interface can also be used to put the module in RF test mode. You cannot use the module over the SPI interface for normal operation as the main host interface.

Antenna	BT800 – The antenna is a ceramic monopole chip antenna.
Band Pass Filter	The band pass filter filters the out-of-band emissions from the transmitter to meet the specific regulations for type approvals of various countries.
EEPROM	There are 64 k bits EEPROM embedded on the BT800 module which can be used to store customizable parameters, such as maximum TX power, PCM configuration, USB product ID, USB vendor ID, and USB product description. With that, the BT800 module can support HID/HCI Proxy mode.
Crystal	The embedded 26 MHz crystal is used for generating the clock for the entire module.

4 SPECIFICATIONS

Table 1: BT800 specifications

Categories	Feature	Implementation
Wireless Specification	Bluetooth®	V4.0 Dual Mode
	Frequency	2.402 - 2.480 GHz
	Maximum Transmit Power	Class 1 +8 dBm from antenna
	Receive Sensitivity	-89 dBm
	Range	Circa 100 meters
	Data Rates	Up to 3 Mbps (over-the-air)
	Host Interface	USB
GPIO		Four configurable lines (1.8V/3.3V configurable by VDD_PADS)
Operational Modes	HCI	Host Controller Interface over USB
	HID Proxy Mode	Human Interface Device
EEPROM	2-wire	64 K bits
Coexistence	802.11 (Wi-Fi)	Three-wire CSR schemes supported (Unity-3; Unity-3e, and Unity+)
Supply Voltage	Supply	5V +/-10% Note: See Implementation Note for details on different DC power selections on the BT800.
	Power Consumption	Current Idle Mode ~5 mA File Transfer ~58 mA
Antenna Option	Internal	Multilayer ceramic antenna with up to 41% efficiency.
Physical	Dimensions	8.5 x 13 x 1.6 mm (BT800 - Module) 16 x 43 x 11 (BT820 – USB Dongle)
	Environmental	Operating
Storage		-40C to +85C
Miscellaneous	Lead Free	Lead-free and RoHS compliant
	Warranty	1-Year Warranty
Approvals	Bluetooth®	Controller Subsystem Approved
	FCC / IC / CE	All BT800 series

5 PIN DEFINITIONS

Table 2: BT800 pin definitions

#	Pin Name	I/O	Supply Domain	Description	If Unused
1	SPI_PCM#_SEL	Input with weak internal pull-down	VDD_PADS	High switches SPI/PCM lines to SPI, Low switches SPI/PCM lines to PCM/PIO *See Note 1.	NC
2	VDD_HOST	Power supply	(3.1V-3.6V)	USB system positive supply	N/A
3	GND	GND	-	Ground	GND
4	USB+	Bidirectional	VDD_HOST	USB data plus with selectable internal 1.5kΩ pull-up resistor	NC
5	USB-	Bidirectional	VDD_HOST		NC
6	GND	GND	-	Ground	GND
7	VREG_IN_USB	Power supply	Analogue regulator input	Input to USB regulator. Connect to external USB bus supply (USB_VBUS)	N/A
8	VREG_EN_RST#	Input with strong internal pull-down	VDD_PADS	Take high to enable internal regulators. Also acts as active low reset. Maximum voltage is VDD_PADS. Note: USB regulator is always enabled and not controlled by this pin.	NC
9	VREG_IN_HV	Analogue regulator input / output	3.3V	Input to internal high-voltage regulator to 1.8V regulator, 3.3V output from USB regulator.	N/A
10	VREG_OUT_HV	Analogue regulator input / output	1.8V	Output from internal high-voltage to 1.8V regulator. Input to second stage internal regulators.	N/A
11	GND	GND	-	Ground	GND
12	GND	GND	-	Ground	GND
13	GND	GND	-	Ground	GND
14	GND	GND	-	Ground	GND
15	GND	GND	-	Ground	GND
16	GND	GND	-	Ground	GND
17	NC	-	-	This pin is reserved for future use. No connection.	-
18	GND	GND	-	Ground	GND
19	PCM_SYNC/ SPI_CS#/ PIO23	Bidirectional, tri-state, with weak internal pull-down	VDD_PADS	PCM synchronous data sync SPI chip select, active low Programmable input/output line *See Note 1.	NC

#	Pin Name	I/O	Supply Domain	Description	If Unused
20	PCM_CLK/ SPI_CLK/ PIO24	Bidirectional, tri-state, with weak internal pull-down	VDD_PADS	PCM synchronous data clock SPI clock Programmable input/output line <i>*See Note 1.</i>	NC
21	PCM_IN/ SPI_MOSI/ PIO21	Input, tri-state, with weak internal pull-down	VDD_PADS	PCM synchronous data input SPI data input Programmable input/output line <i>*See Note 1.</i>	NC
22	PCM_OUT/ SPI_MISO/ PIO22	Output, tri-state, with weak internal pull-down	VDD_PADS	PCM synchronous data output SPI data output Programmable input/output line <i>*See Note 1.</i>	NC
23	PIO0/ WLAN_ACTIVE	Bidirectional, tri-state, with weak internal pull-down	VDD_PADS	Programmable input/output line	NC
24	GND	GND	-	Ground	GND
25	PIO1/ BT_PIRORITY	Bidirectional, tri-state, with weak internal pull-down	VDD_PADS	Programmable input/output line	NC
26	PIO2/ BT_ACTIVE	Bidirectional, tri-state, with weak internal pull-down	VDD_PADS	Programmable input/output line	NC
27	VDD_PADS	Power supply	(1.7V-3.6V)	Positive supply for digital I/O pads	N/A
28	PIO5	Bidirectional, tri-state, with weak internal pull-down	VDD_PADS	Programmable input/output line	NC

Pin Definition Note:

Note 1 | The purpose of the SPI interface is to access the module’s inner settings such as selecting different WLAN CO-EXIST scheme and enabling HID proxy mode. The SPI interface can also be used to put the module in RF test mode. You cannot use the module over the SPI interface for normal operation as the main host interface.

6 DC ELECTRICAL CHARACTERISTICS

Table 3: Absolute maximum ratings

Rating	Min	Max	Unit
Storage temperature	-40	+85	°C
VREG_IN_USB	-0.2	5.75	V
VREG_IN_HV	-0.2	4.9	V

Rating	Min	Max	Unit
VDD_HOST	-0.2	3.7	V
VDD_PADS	-0.2	3.7	V
Other terminal voltages	VSS - 0.4V	VDD + 0.4 V	V

Table 4: Recommended operating conditions

Rating	Min	Max	Unit
Operating temperature	-30	+85	°C
VREG_IN_USB	4.5	5.5	V
VREG_IN_HV	3.1	3.6	V
VDD_HOST	3.1	3.6	V
VDD_PADS	1.7	3.6	V

Table 5: USB Linear Regulator

Rating	Min	Typ	Max	Unit
Input voltage (VREG_IN_USB)	4.5	5.0	5.5	V
Output voltage (VREG_IN_HV)	3.2	3.3	3.4	V
Output current	-	-	150	mA

Table 6: High-voltage Linear Regulator

Normal Operation	Min	Typ	Max	Unit
Input voltage (VREG_IN_HV)	3.1	3.3	3.6	V
Output voltage (VREG_OUT_HV)	1.75	1.85	1.95	V
Temperature coefficient	-200	-	200	ppm/°C
Output noise (frequency range 100Hz to 100kHz)	-	-	0.4	mV rms
Settling time (settling time within 10% of final value)	-	-	5	µs
Output current	-	-	100	mA
Quiescent current (excluding load, load <1mA)	30	40	60	µA
Low-power Mode				
Quiescent current (excluding load, load <100µA)	14	18	23	µA

Table 7: Digital I/O Characteristics

Normal Operation	Min	Typ	Max	Unit
Input Voltage				
VIL input logic level low	-0.4	-	0.4	V
VIH input logic level high	0.7 x VDD	-	VDD + 0.4	V
Output Voltage				

Normal Operation	Min	Typ	Max	Unit
VOL output logic level low, IOL = 4.0 mA	-	-	0.4	V
VOH output logic level high, IOL = 4.0 mA	0.75 x VDD	-	-	V
Input and Tristate Currents				
Strong pull-up	-150	-40	-10	μA
Strong pull-down	10	40	150	μA
Weak pull-up	-5	-1.0	-0.33	μA
Weak pull-down	0.33	1.0	5.0	μA
CI input capacitance	1.0	-	5.0	pF

Table 8: Current Consumption

Normal Operation	Peak (8 dBm)	AVG	Unit
Idle		5	mA
USB Suspend		200	μA
Inquiry	73	51	mA
File Transfer	73	58	mA
LE Connected (Master)	74		mA
LE Scan (Master)	48		mA

7 RF CHARACTERISTICS

Table 9: Receiver characteristics

RF Characteristics, VDD = 3.3V @ room temperature unless otherwise specified	Min	Typ.	Max	BT. Spec.	Unit
Maximum RF Transmit Power		8	10	20	dBm
RF power variation over temperature range		1.5		-	dB
RF power variation over supply voltage range			0.2	-	dB
RF power variation over BT band		2		-	dB
RF power control range	-21		8	-	dBm
20 dB band width for modulated carrier				1000	kHz
ACP	F = F ₀ ± 2MHz			-20	
	F = F ₀ ± 3MHz			-40	
	F = F ₀ > 3MHz			-40	
Drift rate		10		+/-25	kHz
ΔF _{1avg}		165		140<175	kHz
ΔF _{1max}		168		140<175	kHz
ΔF _{2avg} / ΔF _{1avg}		0.9		>=0.8	

Table 10: BDR and EDR receiver sensitivity

RF Characteristics, VDD = 3.3V @ room temp.	Packet Type	Min	Typ	Max	BT. Spec.	Unit
Sensitivity for 0.1% BER	DH1		-89		-70	dBm
	DH3		-89			dBm
	DH5		-89			dBm
	2-DH5		-92			dBm
	3-DH5		-85			dBm
Sensitivity variation over BT band	All		2			dB
Sensitivity variation over temperature range	All		TBD			dB

8 INTERFACE

8.1. PIO

See the Device Terminal Functions section for the list of supplies to the PIOs (Programmable I/O ports).

PIO lines are configured through software to have either weak or strong pull-ups or pull-downs. All PIO lines are configured as inputs with weak pull-downs at reset and have additional individual bus-keeper configuration.

8.2. WLAN Coexistence Interface

Dedicated hardware is provided to implement a variety of WLAN coexistence schemes. There is support for:

- Channel skipping AFH
- Priority signaling
- Channel signaling
- Host passing of channel instructions

The BT800 supports the WLAN coexistence schemes:

- Unity-3
- Unity-3e
- Unity+

For more information see [BT800 WLAN Coexistence Schemes and LED Indication](#).

8.3. USB Interface

BT800 has a full-speed (12 Mbps) USB interface for communicating with other compatible digital devices. The USB interface on the BT800 acts as a USB peripheral, responding to requests from a master host controller.

BT800 supports the Universal Serial Bus Specification (USB v2.0 Specification) and USB Battery Charging Specification, available from <http://www.usb.org>. For more information on how to integrate the USB interface on BT800, see [Figure 19](#) located in the following section: [USB Dongle Design Example Using BT800](#).

As well as describing USB basics and architecture, the application note describes:

- Power distribution for high and low bus-powered configurations
- Power distribution for self-powered configuration, which includes USB VBUS monitoring
- USB enumeration
- Electrical design guidelines for power supply and data lines, as well as PCB tracks and effects of ferrite beads

- USB suspend modes and Bluetooth low-power modes
- Global suspend
- Selective suspend, includes remote wake
- Wake on Bluetooth, includes permitted devices and set-up prior to selective suspend
- Suspend mode current draw
- PIO status in suspend mode
- Resume, detach, and wake PIOs
- Battery charging from USB: dead battery provision, charge currents, charging in suspend modes and USB
- VBUS voltage consideration
- USB termination when interface is not in use
- Internal modules, certification and non-specification compliant operation

8.4. PCM Interface

The audio PCM interface on the BT800 supports:

- Continuous transmission and reception of PCM encoded audio data over Bluetooth.
- Processor overhead reduction through hardware support for continual transmission and reception of PCM data.
- A bidirectional digital audio interface that routes directly into the baseband layer of the firmware. It does not pass through the HCI protocol layer.
- Hardware on the BT800 for sending data to and from a SCO connection.
- Up to three SCO connections on the PCM interface at any one time.
- PCM interface master, generating PCM_SYNC and PCM_CLK.
- PCM interface slave, accepting externally generated PCM_SYNC and PCM_CLK.
- Various clock formats including:
 - Long Frame Sync
 - Short Frame Sync
- GCI timing environments.
- 13-bit or 16-bit linear, 8-bit μ -law, or A-law companded sample formats.
- Receives and transmits on any selection of three of the first four slots following PCM_SYNC.

The PCM configuration options are enabled by setting PSKEY_PCM_CONFIG32.

8.4.1. PCM Interface Master/Slave

When configured as the master of the PCM interface, the BT800 generates PCM_CLK and PCM_SYNC.

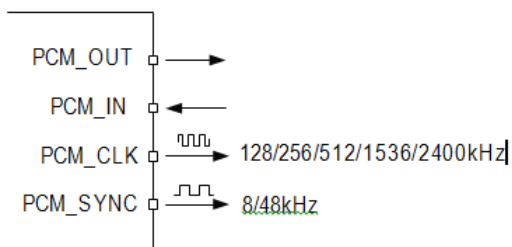

Figure 2: PCM Interface Master

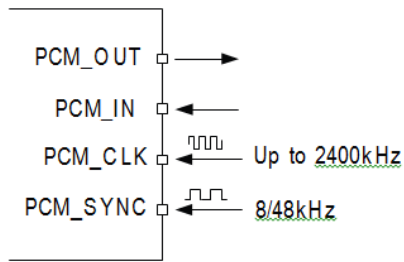

Figure 3: PCM Interface Slave

8.4.2. Long Frame Sync

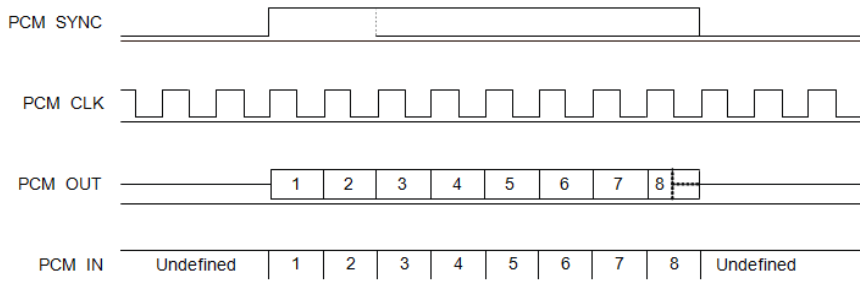

Figure 4: Long Frame Sync (shown with 8-bit Companded Sample)

Long Frame Sync is the name given to a clocking format that controls the transfer of PCM data words or samples. In Long Frame Sync, the rising edge of PCM_SYNC indicates the start of the PCM word. When the BT800 is configured as PCM master, generating PCM_SYNC and PCM_CLK, then PCM_SYNC is eight bits long. When the BT800 is configured as PCM Slave, PCM_SYNC is from one cycle PCM_CLK to half the PCM_SYNC rate. BT800 samples PCM_IN on the falling edge of PCM_CLK and transmits PCM_OUT on the rising edge. PCM_OUT is configurable as high impedance on the falling edge of PCM_CLK in the LSB position or on the rising edge.

8.4.3. Short Frame Sync

In Short Frame Sync, the falling edge of PCM_SYNC indicates the start of the PCM word. PCM_SYNC is always one clock cycle long.

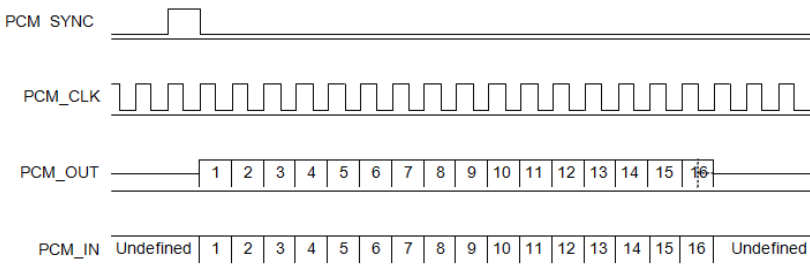

Figure 5: Short Frame Sync (Shown with 16-bit Sample)

As with Long Frame Sync, BT800 samples PCM_IN on the falling edge of PCM_CLK and transmits PCM_OUT on the rising edge. PCM_OUT is configurable as high impedance on the falling edge of PCM_CLK in the LSB position or on the rising edge.

8.4.4. Multi-Slot Operation

More than 1 SCO connection over the PCM interface is supported using multiple slots. Up to 3 SCO connections are carried over any of the first 4 slots.

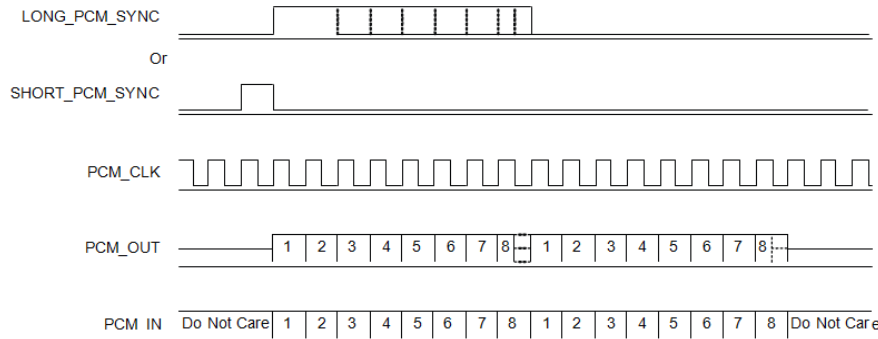

Figure 6: Multi-slot operation with 2 Slots and 8-bit companded samples

8.5. GCI Interface

BT800 is compatible with the GCI, a standard synchronous 2B+D ISDN timing interface. The two 64 kbps B channels are accessed when this mode is configured.

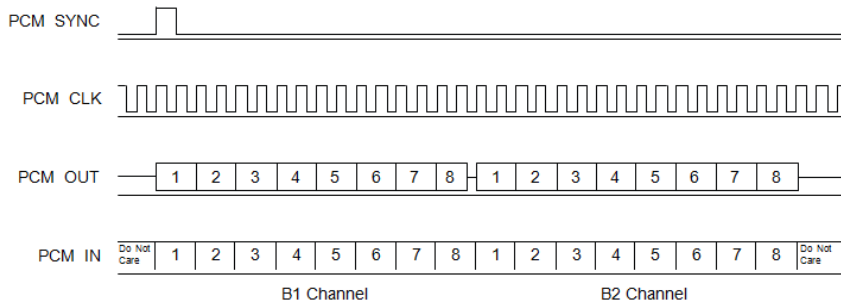

Figure 7: Multi-slot operation

The start of frame is indicated by the rising edge of PCM_SYNC and runs at 8 kHz.

8.6. Slots and Sample Formats

BT800 receives and transmits on any selection of the first four slots following each sync pulse. Slot durations are either 8 or 16 clock cycles:

- 8 clock cycles for 8-bit sample formats.
- 16 clock cycles for 8-bit, 13-bit, or 16-bit sample formats.

BT800 supports:

- 13-bit linear, 16-bit linear and 8-bit μ -law or A-law sample formats
- A sample rate of 8 kbps
- Little or big endian bit order
- For 16-bit slots, the three or eight unused bits in each slot are filled with sign extension, padded with zeros or a programmable 3-bit audio attenuation compatible with some codecs.

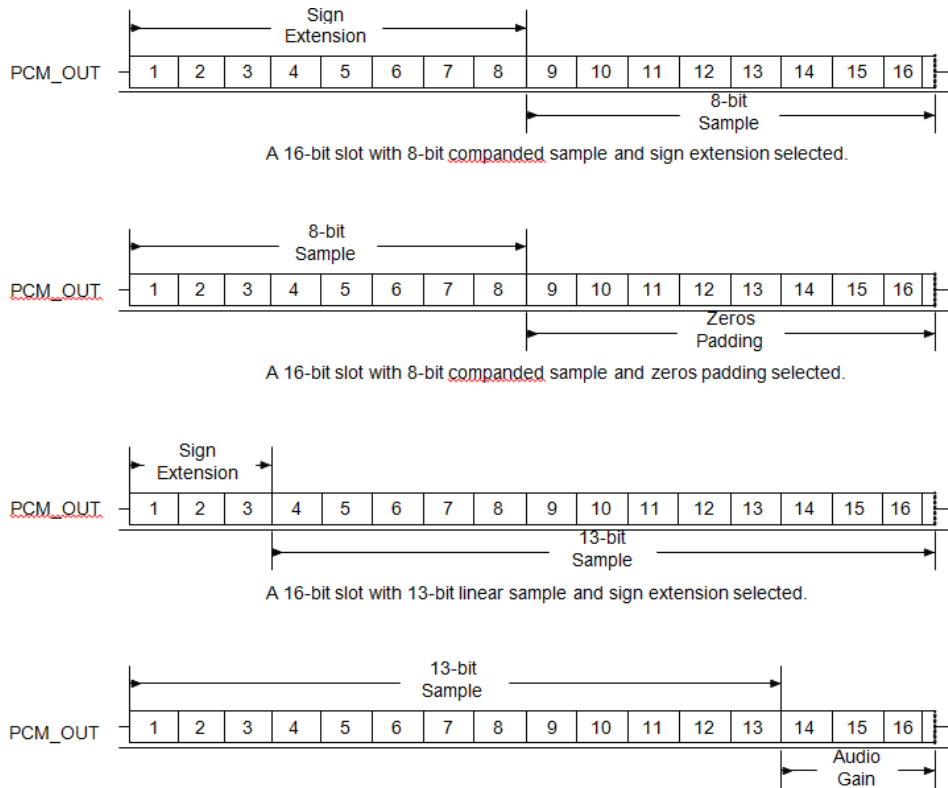

Figure 8: 16-bit slot length and sample formats

8.7. PCM Timing Information

Table 11: PCM Timing information

Symbol	Parameter	Min	Typ	Max	Unit	
f _{mclk}	PCM_CLK frequency	4MHz DDS generation. Frequency selection is programmable.	128	-	-	kHz
			256	-	-	
			512	-	-	
-	PCM_SYNC frequency for SCO connection	2.9	-	-	kHz	
t _{mclkh} (a)	PCM_CLK high	980	-	-	ns	
t _{mckl} (a)	PCM_CLK low	730	-	-	ns	
-	PCM_CLK jitter	-	-	21	ns pk-pk	
t _{dmcklsynch}	Delay time from PCM_CLK high to PCM_SYNC high	4MHz DDS generation	-	20	ns	
		48MHz DDS generation	-	40.83	ns	
t _{dmcklpout}	Delay time from PCM_CLK high to valid PCM_OUT	-	-	20	ns	

Symbol	Parameter	Min	Typ	Max	Unit	
$t_{dmcklsync}$	Delay time from PCM_CLK low to PCM_SYNC low (long frame sync only)	4MHz DDS generation	-	-	20	ns
		48MHz DDS generation	-	-	40.83	ns

(a) Assumes normal system clock operation. Figures vary during low-power modes, when system clock speeds are reduced.

Table 12: PCM Master mode timing parameters

Symbol	Parameter	Min	Typ	Max	Unit	
$t_{dmckhsync}$	Delay time from PCM_CLK high to PCM_SYNC low	4MHz DDS generation	-	-	20	ns
		48MHz DDS generation	-	-	40.83	ns
$t_{dmcklpoutz}$	Delay time from PCM_CLK low to PCM_OUT high impedance	-	-	20	ns	
$t_{dmckhpoutz}$	Delay time from PCM_CLK high to PCM_OUT high impedance	-	-	20	ns	
$t_{supinckl}$	Set-up time for PCM_IN valid to PCM_CLK low	20	-	-	ns	
$t_{hpinckl}$	Hold time for PCM_CLK low to PCM_IN invalid	0	-	-	ns	

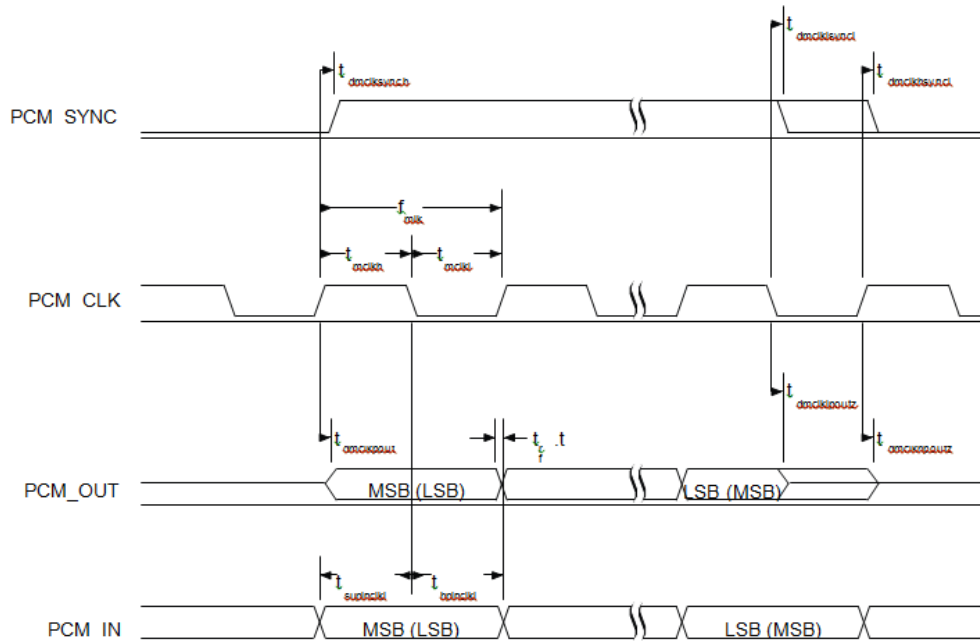

Figure 9: PCM Master timing long frame sync

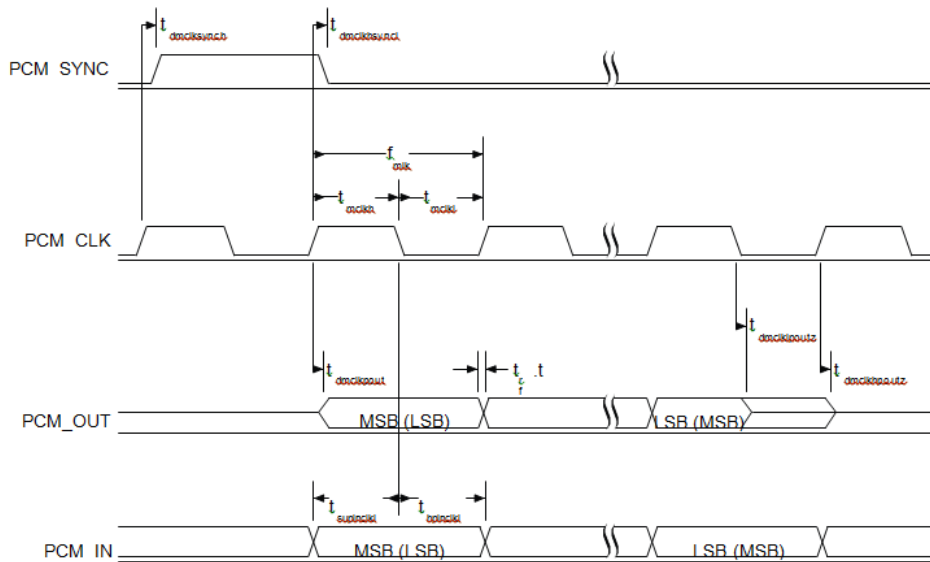

Figure 10: PCM Master timing short frame sync

8.8. PCM Slave Timing

Symbol	Parameter	Min	Typ	Max	Unit
f_{sclk}	PCM clock frequency (Slave mode: input)	64	-	2048	kHz
f_{sclk}	PCM clock frequency (GCI mode)	128	-	4096	kHz
t_{sckl}	PCM_CLK low time	200	-	-	ns
t_{sckh}	PCM_CLK high time	200	-	-	ns

8.9. PCM Slave Mode Timing Parameters

Symbol	Parameter	Min	Typ	Max	Unit
$t_{hscklsynch}$	Hold time from PCM_CLK low to PCM_SYNC high	2	-	-	ns
$t_{suscklsynch}$	Set-up time for PCM_SYNC high to PCM_CLK low	20	-	-	ns
t_{dpout}	Delay time from PCM_SYNC or PCM_CLK, whichever is later, to valid PCM_OUT data (long frame sync only)	-	-	15	ns
$t_{dscklhpout}$	Delay time from CLK high to PCM_OUT valid data	-	-	15	ns
t_{dpoutz}	Delay time from PCM_SYNC or PCM_CLK low, whichever is later, to PCM_OUT data line high impedance	-	-	20	ns
$t_{supinsckl}$	Set-up time for PCM_IN valid to CLK low	20	-	-	ns
$t_{hpinsckl}$	Hold time for PCM_CLK low to PCM_IN invalid	2	-	-	ns

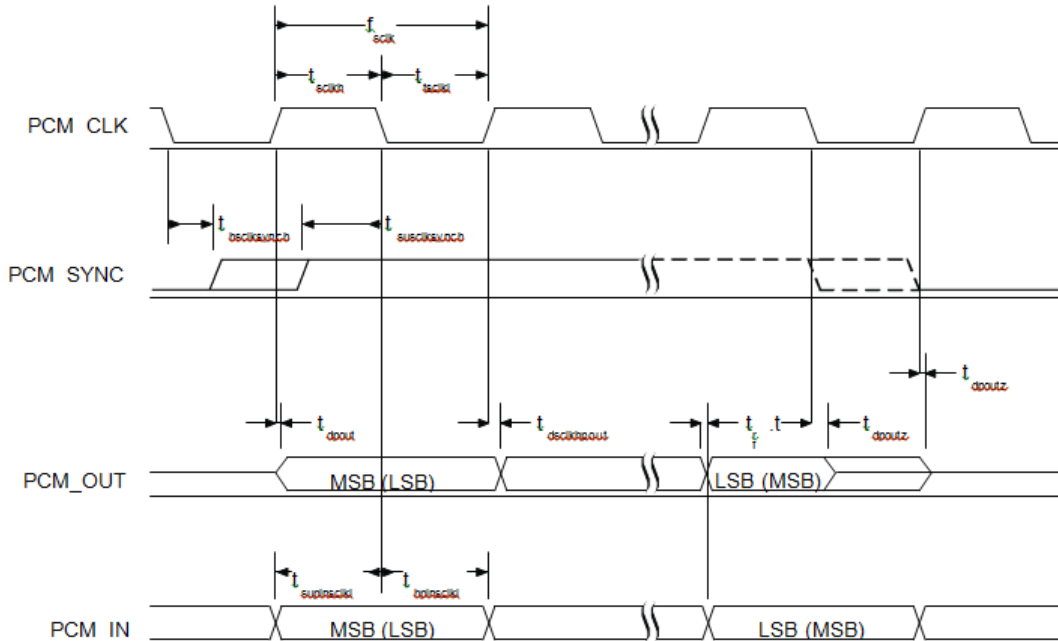

Figure 11: PCM Slave timing long frame sync

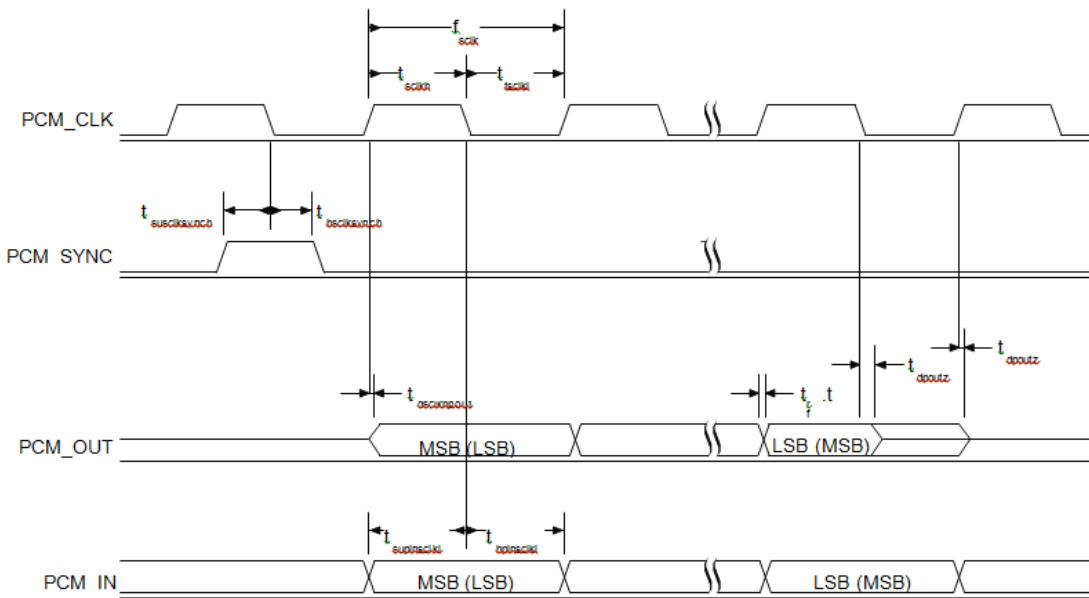

Figure 12: PCM Slave timing short frame sync

8.10. PCM_CLK and PCM_SYNC Generation

BT800 has two methods of generating PCM_CLK and PCM_SYNC in master mode:

- Generating these signals by DDS from BT800 internal 4MHz clock. Using this mode limits PCM_CLK to 128, 256 or 512 kHz and PCM_SYNC to 8 kHz.
- Generating these signals by DDS from an internal 48MHz clock, which enables a greater range of frequencies to be generated with low jitter but consumes more power. To select this second method set bit 48M_PCM_CLK_GEN_EN in PSKEY_PCM_CONFIG32. When in this mode and with long frame sync, the

length of PCM_SYNC is either 8 or 16 cycles of PCM_CLK, determined by LONG_LENGTH_SYNC_EN in PSKEY_PCM_CONFIG32.

Equation Error! No text of specified style in document..1 describes PCM_CLK frequency when generated from the internal 48MHz clock:

$$f = \frac{\text{CNT_RATE}}{\text{CNT_LIMIT}} \times 24\text{MHz}$$

Equation Error! No text of specified style in document..1: PCM_CLK frequency generated using the internal 48MHz clock

Set the frequency of PCM_SYNC relative to PCM_CLK using **Equation Error! No text of specified style in document..2**:

$$f = \frac{\text{PCM_CLK}}{\text{SYNC_LIMIT} \times 8}$$

Equation Error! No text of specified style in document..2: PCM_SYNC frequency relative to PCM_CLK

CNT_RATE, CNT_LIMIT and SYNC_LIMIT are set using PSKEY_PCM_LOW_JITTER_CONFIG. As an example, to generate PCM_CLK at 512kHz with PCM_SYNC at 8kHz, set SKEY_PCM_LOW_JITTER_CONFIG to 0x08080177.

8.11. PCM Configuration

Configure the PCM by using PSKEY_PCM_CONFIG32 and PSKEY_PCM_LOW_JITTER_CONFIG (See your PSKey file). The default for PSKEY_PCM_CONFIG32 is 0x00800000 (for example: first slot following sync is active, 13-bit linear voice format, long frame sync and interface master generating 256kHz PCM_CLK from 4MHz internal clock with no tri-state of PCM_OUT).

8.12. Digital Audio Interface (I²S)

The digital audio interface supports the industry standard formats for I²S, left-justified or right-justified. The interface shares the same pins as the PCM interface, which means each audio bus is mutually exclusive in its usage. [Table 13](#) lists these alternative functions. [Figure 11](#) shows the timing diagram.

Table 13: Alternative functions of the digital audio bus interface on the PCM interface.

PCM Interface	I ² S Interface
PCM_OUT	SD_OUT
PCM_IN	SD_IN
PCM_SYNC	WS
PCM_CLK	SCK

Configure the digital audio interface using PSKEY_DIGITAL_AUDIO_CONFIG, see BlueCore Audio API Specification and the PS Key file.

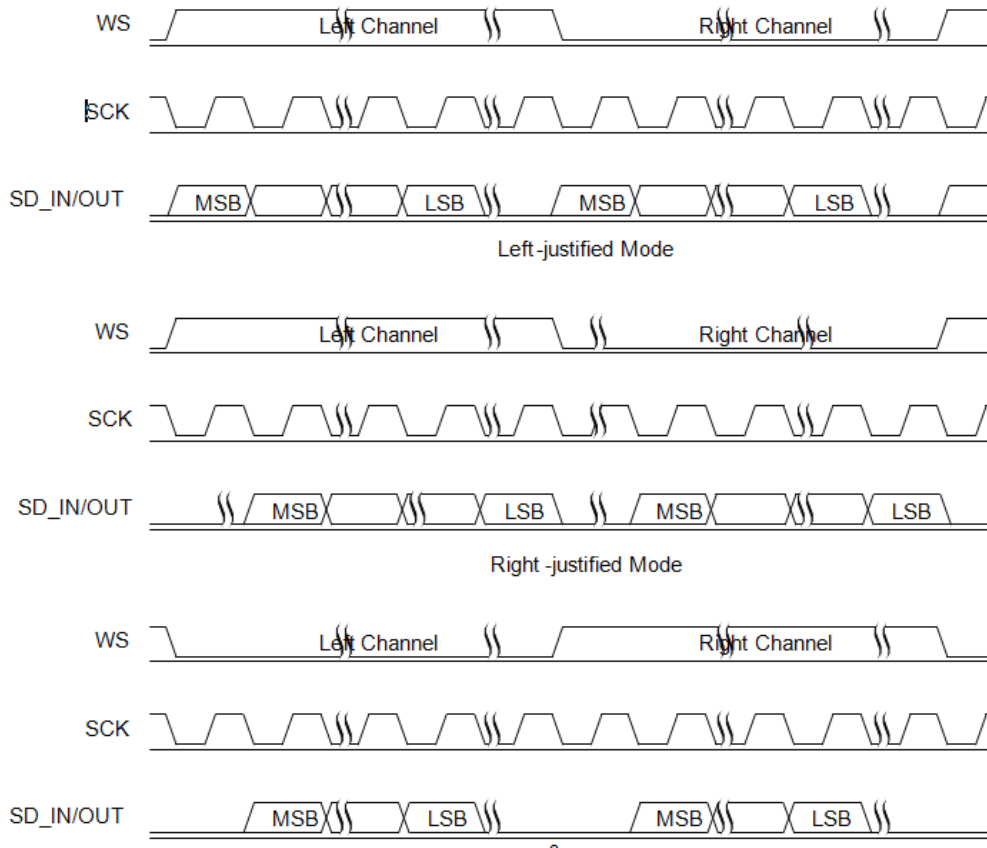

Figure 13: PCM configuration

The internal representation of audio samples within BT800 is 16-bit and data on SD_OUT is limited to 16-bit per channel.

Table 14: Digital audio interface slave timing

Symbol	Parameter	Min	Typ	Max	Unit
-	SCK Frequency	-	-	6.2	MHz
-	WS Frequency	-	-	96	kHz
t _{ch}	SCK high time	80	-	-	ns
t _{cl}	SCK low time	80	-	-	ns

Table 15: I²S slave mode timing

Symbol	Parameter	Min	Typ	Max	Unit
t _{ssu}	WS valid to SCK high set-up time	20	-	-	ns
t _{sh}	SCK high to WS invalid hold time	2.5	-	-	ns
t _{opd}	SCK low to SD_OUT valid delay time	-	-	20	ns
t _{isu}	SD_IN valid to SCK high set-up time	20	-	-	ns
t _{ih}	SCK high to SD_IN invalid hold time	2.5	-	-	ns

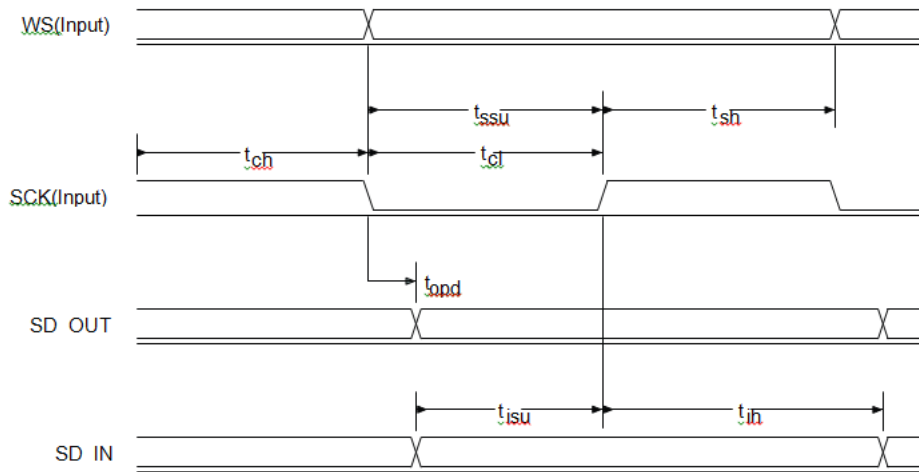

Figure 14: Digital audio interface slave timing

Table 16: Digital audio interface master timing

Symbol	Parameter	Min	Typ	Max	Unit
-	SCK Frequency	-	-	6.2	MHz
-	WS Frequency	-	-	96	kHz

Table 17: I²S Master mode timing parameters, WS and SCK as outputs

Symbol	Parameter	Min	Typ	Max	Unit
t _{spd}	SCK low to WS valid delay time	-	-	39.27	ns
t _{opd}	SCK low to SD_OUT valid delay time	-	-	18.44	ns
t _{isu}	SD_IN valid to SCK high set-up time	18.44	-	-	ns
t _{ih}	SCK high to SD_IN invalid hold time	0	-	-	ns

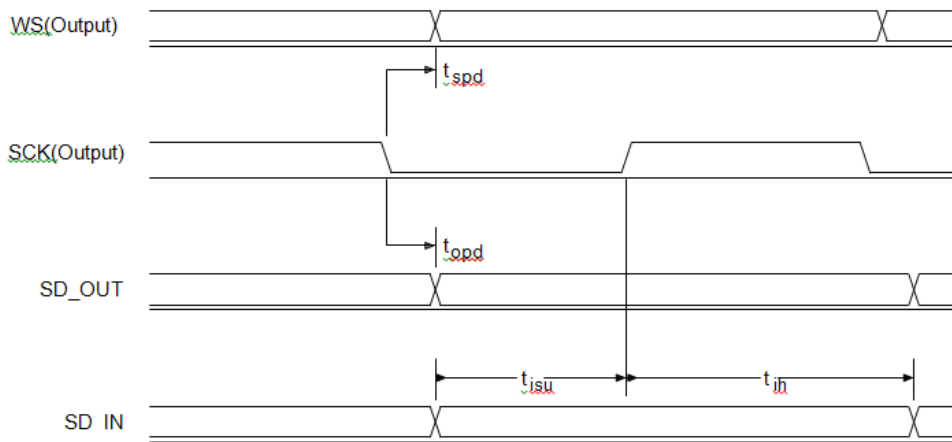

Figure 15: Digital audio interface master timing

9 POWER CONTROL AND REGULATION

See the Example Application Schematic (Figure 19) for the regulator configuration. BT800 contains three regulators:

- USB linear regulator, to generate the 3.3 V from the USB bus power and the input to the high-voltage linear regulator.
- High-voltage linear regulator, to generate the main 1.8 V from the USB linear regulator or an external 3.3 V.

This regulator then feeds the three low-voltage regulators:

- Low-voltage VDD_DIG linear regulator, a programmable low-voltage regulator to supply a 0.90 V to 1.25 V digital supply, VDD_DIG.
- Low-voltage VDD_ANA linear regulator, to supply the radio supply, VDD_RADIO.
- Low-voltage VDD_AUX linear regulator, to supply the auxiliary supply, VDD_AUX.

9.1. USB Linear Regulator

The integrated USB LDO linear regulator is available as a 3.3V supply rail (VREG_IN_HV) and is intended to supply the USB interface and the high-voltage linear regulator. The input voltage range supplied at VREG_IN_USB is between 4.25V and 5.75V. VREG_IN_HV serves as both the output for the USB linear regulator and the input to the High-voltage linear regulator. The maximum current from this regulator is 150 mA, of which 50 mA is available for external use (for example, EEPROM/LED). This regulator is internally decoupled and no external decoupling caps are required on the VREG_IN_HV pin, however in noisy environments, an output capacitor of 1uF to 4.7uF (+/-20%) is suggested.

This regulator is enabled by default. If the USB linear regulator is not required, leave its input (VREG_IN_USB) unconnected and connect 3.3V to VREG_IN_HV (if using the High-voltage linear regulator), VDD_HOST, VDD_EN_RST#, and VDD_PADS (if using 3.3V I/O).

9.2. High-voltage Linear Regulator

The integrated high-voltage linear regulator is available to power the main 1.8V supply rail including the three internal low-voltage linear regulators VDD_DIG, VDD_ANA, and VDD_AUX. The input voltage range supplied at VREG_IN_HV is between 2.3V and 4.8V. VREG_OUT_HV serves as both the output to the high-voltage linear regulator and the input to the internal low voltage regulators. The maximum current from this regulator is 100

mA; this regulator is not available for external use. This regulator is internally decoupled and no external decoupling caps are required on the VREG_IN_HV pin, however in noisy environments, an output capacitor of 1uF to 4.7uF (+/-20%) is suggested.

If this regulator is not required, and the USB linear regulator is not used then leave VREG_IN_HV unconnected and connect 1.8V to VREG_OUT_HV.

9.3. Voltage Regulator Enable and Reset

A single pin, VREG_EN_RST#, controls both the regulator enables and the digital reset function. All the regulators are enabled, except the USB linear regulator, by taking the VREG_EN_RST# pin above 1 volt. Software also controls the regulators. The VREG_EN_RST# pin is connected internally to the reset function and is powered from VDD_HOST, so do not apply voltages above VDD_HOST to the VREG_EN_RST# pin. The REG_EN_RST# pin is pulled down internally before the software starts. The VREG_EN_RST# pin is an active low reset. Assert the reset signal for a period >5 ms to ensure a full reset.

Note: The regulator enables are released as soon as VREG_EN_RST# is low, so the regulators shut down. Therefore do not take VREG_EN_RST# low for less than 5 ms, as a full reset is not guaranteed.

Other reset sources are:

- Power-on reset
- Via a software-configured watchdog timer

A warm reset function is also available under software control. After a warm reset the RAM data remains available.

9.4. Power Sequencing

CSR recommends that all power supplies are powered at the same time. The order of powering the supplies relative to the I/O supply, VDD_PADS to VDD_HOST, is not important. If the I/O supply is powered before VDD_DIG, all digital I/Os are weak pull-downs regardless of the reset state.

10 ANTENNA PERFORMANCE

Figure 16 illustrates antenna performance.

Gain Table

Unit in dBi @2.44GHz	XY-plane		XZ-plane		YZ-plane		Efficiency
	Peak	Avg.	Peak	Avg.	Peak	Avg.	
A1	-3.5	-4.2	3.8	-5.3	3.2	-4.7	41.0%

Figure 16: BT800 gain table

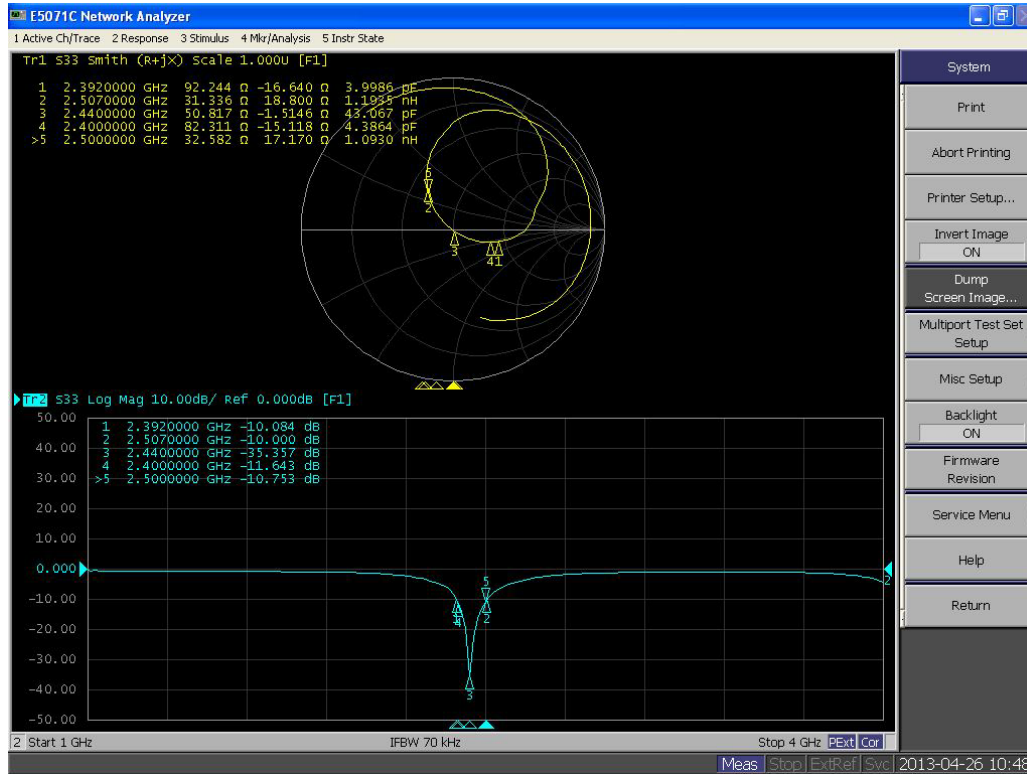
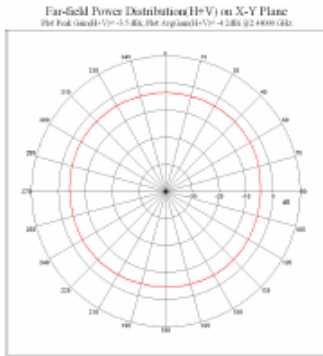

Figure 17: Network analyzer output

◆ **XY-plane**



Unit : dBi

	Peak gain	Avg. gain
XY-plane	-3.5	-4.2

◆ **XZ-plane**

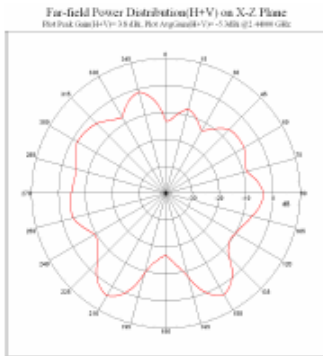

	Peak gain	Avg. gain
XZ-plane	3.8	-5.3

◆ **YZ-plane**

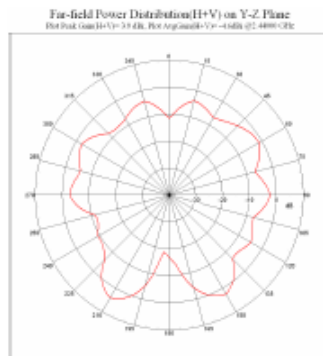

	Peak gain	Avg. gain
YZ-plane	3.2	-4.7

11 MECHANICAL DIMENSIONS AND LAND PATTERN

11.1. BT800 Mechanical Drawing

Bottom View Device Pads

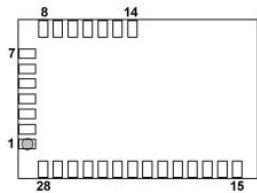

Side View

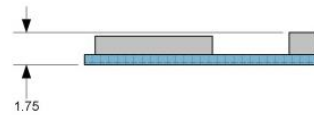

**Top View
 Recommended PCB Layout**

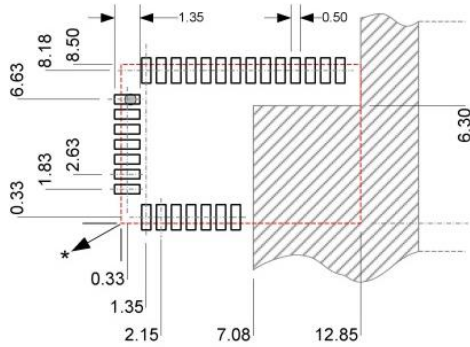

* Dimensions from corner of BT800 edge

● Pin1

No Copper in this area!

BT800 PCB Edge

Top View

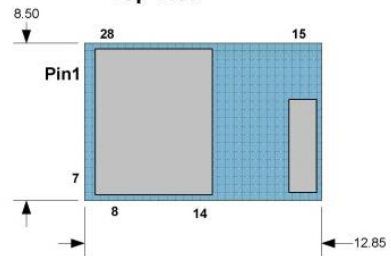

Note: Dimensions are in millimetres.
 Tolerances: .xx ±0.03 mm
 .x ±1.3 mm

12 IMPLEMENTATION NOTE

12.1. PCB Layout on Host PCB

Checklist (for PCB):

- **Must** locate the BT800 module close to the edge of PCB.
- Use solid GND plane on inner layer (for best EMC and RF performance).
- Place GND vias close to module GND pads as possible
- Route traces to avoid noise being picked up on VCC supply.
- Antenna Keep-out area:
 - Ensure there is no copper in the antenna keep-out area on any layers of the host PCB.
 - Keep all mounting hardware and metal clear of the area to allow proper antenna radiation.
 - For best antenna performance, place the BT800 module on the edge of the host PCB, preferably in the corner with the antenna facing the corner.
 - A different host PCB thickness dielectric will have small effect on antenna.

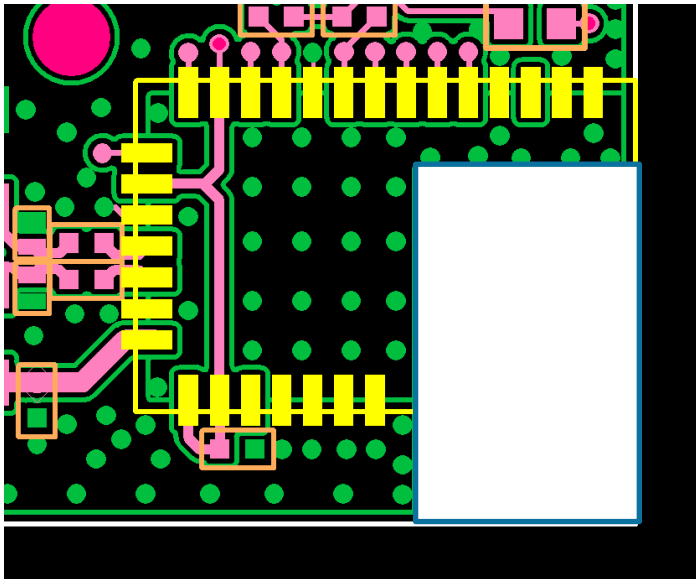

Figure 18: Recommend Antenna keep-out area (in White) used on the BT800

12.1.1. Antenna Keep-out and Proximity to Metal or Plastic

Checklist (for metal /plastic enclosure):

- Minimum safe distance for metals without seriously compromising the antenna (tuning) is 40 mm top/bottom and 30 mm left or right.
- Metal close to the BT800 chip monopole antenna (bottom, top, left, right, any direction) will have degradation on the antenna performance. The amount of degradation is entirely system dependent which means some testing by customers is required (in their host application).
- Any metal closer than 20 mm starts to significantly degrade performance (S11, gain, radiation efficiency).
- It is best that the customer tests the range with mock-up (or actual prototype) of the product to assess effects of enclosure height (and material whether metal or plastic).

1.1.1 USB Dongle Design Example Using BT800

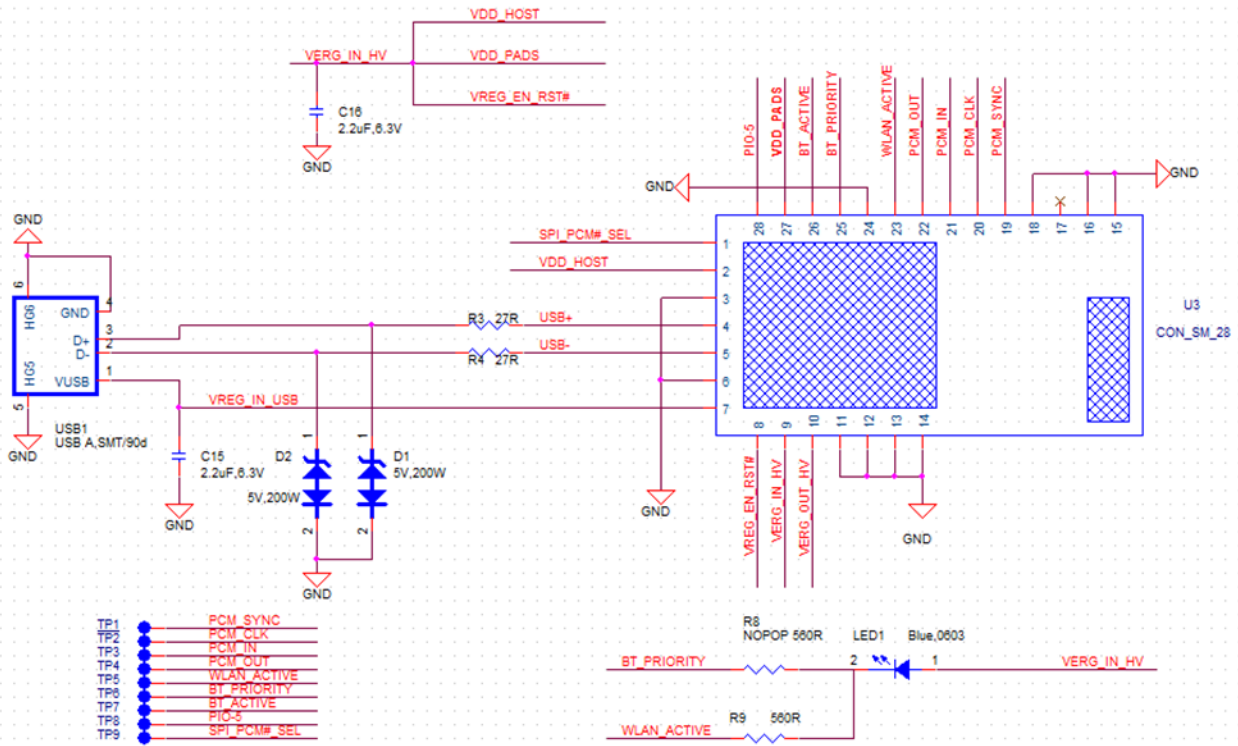

Figure 19: USB dongle design schematic

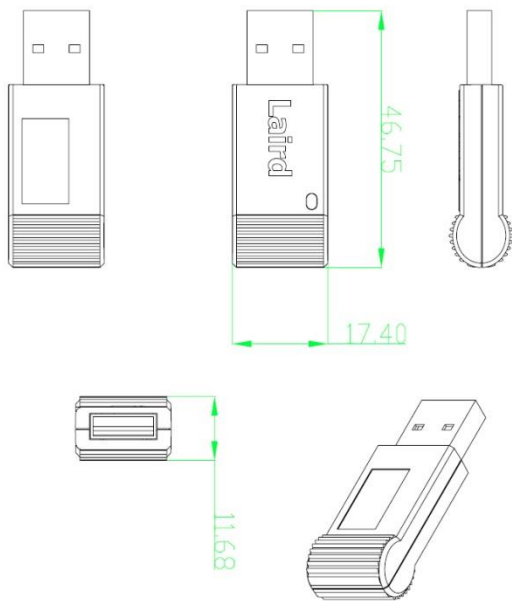

Figure 20: BT820 USB dongle, containing embedded BT800

12.1.2. DC Power Supply Options for Using the BT800 Module

- Using USB bus power (5V±10%)
 Apply USB bus power (5V ±10%) directly to the Pin-7 (VREG_IN_USB) and pull-high on Pin-8 (VREG_EN_RST#) to turn on the internal regulator. The BT800 module generates 3.3 V/1.8 V output on Pin-9 (VREG_IN_HV)/Pin-10 (VREG_OUT_HV) that can supply to the other DC pin of the board.
- Using DC power 3.3 V
 Leave the Pin-7 (VREG_IN_USB) no connection, power the on Pin-9 (VREG_IN_HV) with 3.3 V and pull-high on Pin-8 (VREG_EN_RST#) to turn on the internal regulator. The BT800 module generates 1.8 V output on Pin-10 (VREG_OUT_HV) which can supply to the other DC pin of the board.

13 APPLICATION NOTE FOR SURFACE MOUNT MODULES

13.1. Introduction

Laird surface mount modules are designed to conform to all major manufacturing guidelines. This application note is intended to provide additional guidance beyond the information that is presented in the user manual. This application note is considered a living document and is updated as new information is presented.

The modules are designed to meet the needs of a number of commercial and industrial applications. They are easy to manufacture and they conform to current automated manufacturing processes.

13.2. Shipping

13.2.1. Tray Package

Modules are shipped in ESD (Electrostatic Discharge) safe trays that can be loaded into most manufacturers pick and place machines. Layouts of the trays are provided in [Figure 21](#).

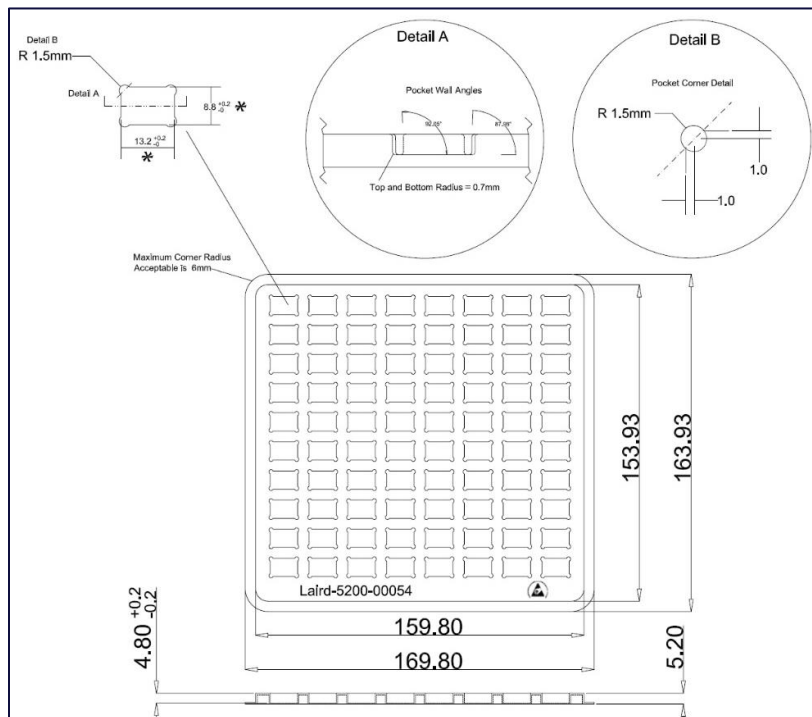

Figure 21: Shipping tray layout

13.2.2. Tape and Reel Package Information

Note: Ordering information for Tape and Reel packaging is an addition of T/R to the end of the full module part number. For example, BT800 becomes BT800-xx-T/R.

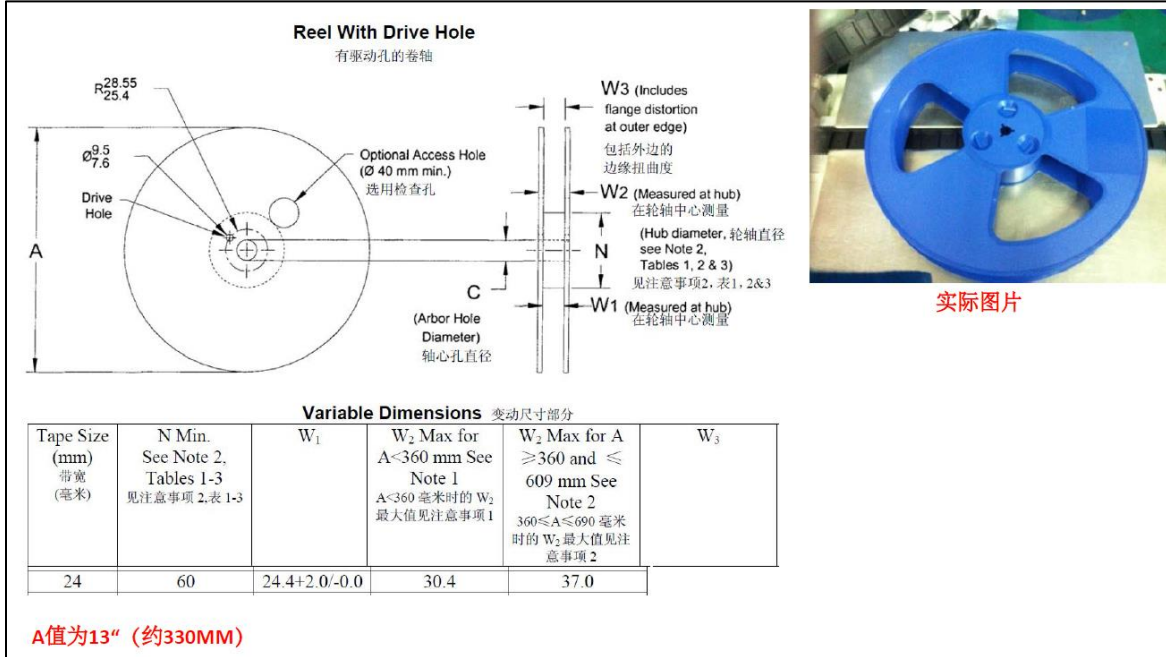

Figure 22: Reel specifications

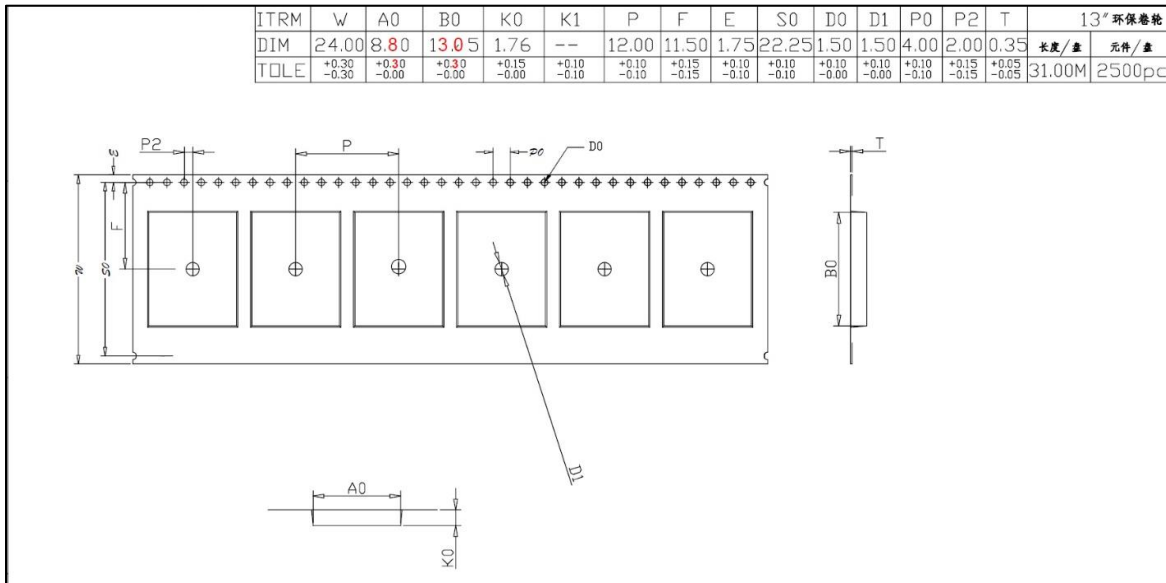

Figure 23: Tape specifications

There are 2500 BT800 modules taped in a reel (and packaged in a pizza box) and five boxes per carton (12,500 modules per carton). Reel, boxes, and carton are labeled with the appropriate labels. See following images (Figures 24-32).

1.1.1.1 Packaging Process

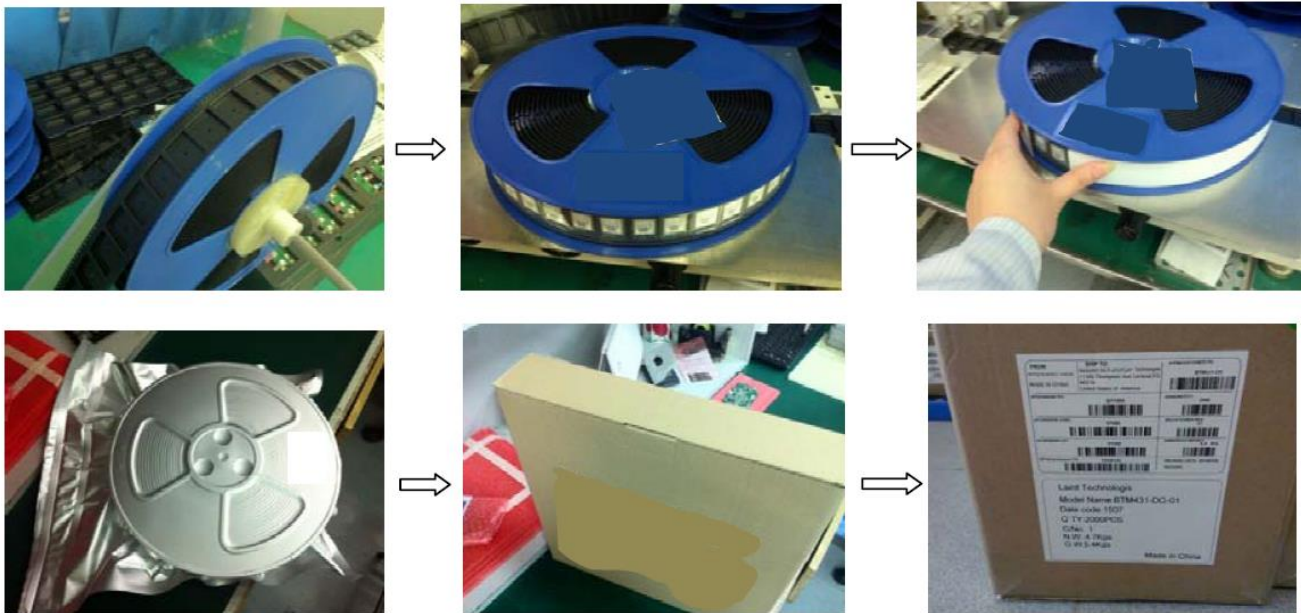

Figure 24: BT800 packaging process

13.3. Reflow Parameters

Laird surface mount modules are designed to be easily manufactured, including reflow soldering to a PCB. Ultimately it is the responsibility of the customer to choose the appropriate solder paste and to ensure oven temperatures during reflow meet the requirements of the solder paste. Laird’s surface mount modules conform to J-STD-020D1 standards for reflow temperatures.

Important: During reflow, modules should not be above 260° and not for more than 30 seconds.

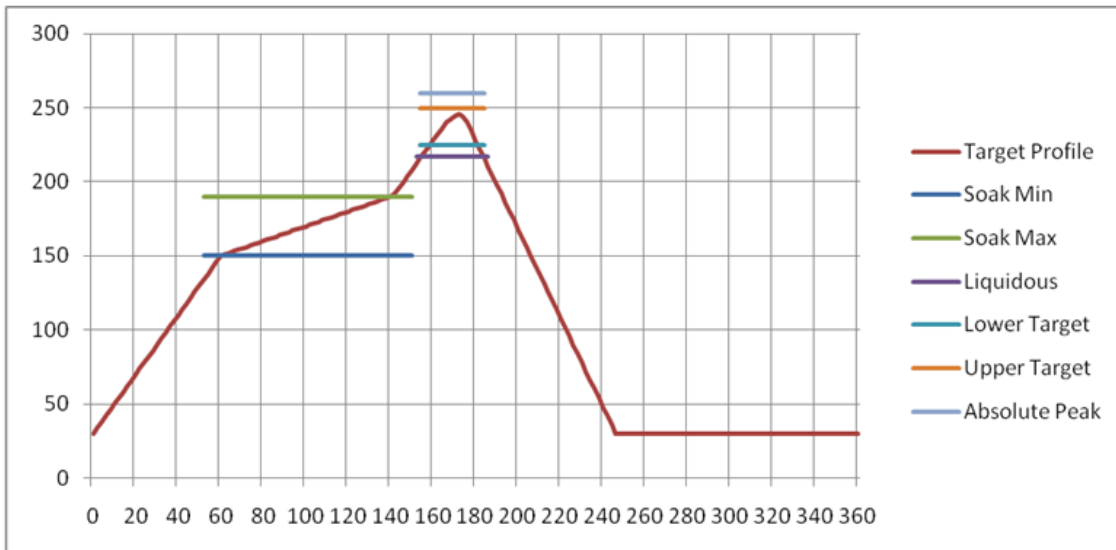

Figure Error! No text of specified style in document.-25: Recommended reflow temperature

Temperatures should not exceed the minimums or maximums presented in [Table 18](#).

Table 18: Recommended maximum and minimum temperatures

Specification	Value	Unit
Temperature Inc./Dec. Rate (max)	1~3	°C / Sec
Temperature Decrease rate (goal)	2-4	°C / Sec
Soak Temp Increase rate (goal)	.5 - 1	°C / Sec
Flux Soak Period (Min)	70	Sec
Flux Soak Period (Max)	120	Sec
Flux Soak Temp (Min)	150	°C
Flux Soak Temp (max)	190	°C
Time Above Liquidous (max)	70	Sec
Time Above Liquidous (min)	50	Sec
Time In Target Reflow Range (goal)	30	Sec
Time At Absolute Peak (max)	5	Sec
Liquidous Temperature (SAC305)	218	°C
Lower Target Reflow Temperature	240	°C
Upper Target Reflow Temperature	250	°C
Absolute Peak Temperature	260	°C

14 JAPAN (MIC) REGULATORY

The BT800 is approved for use in the Japanese market. The part numbers listed below hold WW type certification. Refer to **ARIB-STD-T66** for further guidance on OEM’s responsibilities.

Model	Product Name	Description	Certificate Number
BT800	BT v4.0 Dual Mode USB HCI Module	Mounted with chipset antenna	003-150186

14.1. Antenna Information

The BT800 was tested with antennas listed below. The OEM can choose a different manufacturers antenna but must make sure it is of same type and that the gain is lesser than or equal to the antenna that is approved for use.

Item	Part Number	Mfg.	Type	Gain (dBi)
1	AT3216-B2R7HAA_3216	ACX	Chip	0.5

15 FCC AND IC REGULATORY

Model	US/FCC	CANADA/IC
BT800	SQGBT800	3147A-BT800
BT820	SQGBT800	3147A-BT800
DVK-BT800	SQGBT800	3147A-BT800

The BT800 family has been designed to operate with the antenna listed below having a maximum gain of 0.5 dBi. The required antenna impedance is 50 ohms.

Item	Part Number	Mfg.	Type	Gain (dBi)
1	AT3216-B2R7HAA	ACX	Ceramic	0.5

15.1. Documentation Requirements

In order to ensure regulatory compliance, when integrating the BT800 into a host device, it is necessary to meet the documentation requirements set forth by the applicable regulatory agencies. The following sections (FCC, Industry Canada, and European Union) outline the information that may be included in the user's guide and external labels for the host devices into which the BT800 is integrated.

FCC

Note: You must place "Contains FCC ID: SQG-BT800" on the host product in such a location that it can be seen by an operator at the time of purchase.

User's Guide Requirements

The BT800 complies with FCC Part 15 Rules for a Modular Approval. To leverage Laird's grant, the conditions below must be met for the host device into which the BT800 is integrated:

- The transmitter module is not co-located with any other transmitter or antenna that is capable of simultaneous operation.

As long as the conditions above are met, further transmitter testing is typically not required. However, the OEM integrator is still responsible for testing its end-product for any additional compliance requirements required with this module installed, such as (but not limited to) digital device emissions and PC peripheral requirements.

IMPORTANT:

In the event that the conditions above cannot be met (for example certain device configurations or co-location with another transmitter), then the FCC authorization is no longer considered valid and the FCC ID cannot be used on the final product. In these circumstances, the OEM integrator will be responsible for re-evaluating the end product (including the transmitter) and obtaining a separate FCC authorization.

When using Laird's FCC grant for the BT800, the integrator must include specific information in the user's guide for the device into which the BT800 is integrated. The integrator must not provide information to the end user regarding how to install or remove this RF module in the user's manual of the device into which the BT800 is integrated. The following FCC statements must be added in their entirety and without modification into a prominent place in the user's guide for the device into which the BT800 is integrated:

IMPORTANT NOTE: To comply with FCC requirements, the BT800 must not be co-located or operating in conjunction with any other antenna or transmitter.

Federal Communication Commission Interference Statement

This equipment has been tested and found to comply with the limits for a Class B digital device, pursuant to Part 15 of the FCC Rules. These limits are designed to provide reasonable protection against harmful interference in a residential installation. This equipment generates, uses, and can radiate radio frequency energy and, if not installed and used in accordance with the instructions, may cause harmful interference to radio communications. However, there is no guarantee that interference will not occur in a particular installation. If this equipment does cause harmful interference to radio or television reception, which can be determined by turning the equipment off and on, the user is encouraged to try to correct the interference by one of the following measures:

1. Reorient or relocate the receiving antenna.
2. Increase the separation between the equipment and receiver.
3. Connect the equipment into an outlet on a circuit different from that to which the receiver is connected.
4. Consult the dealer or an experienced radio/TV technician for help.

FCC Caution: Any changes or modifications not expressly approved by the party responsible for compliance could void the user's authority to operate this equipment.

This device complies with Part 15 of the FCC Rules. Operation is subject to the following two conditions: (1) This device may not cause harmful interference, and (2) this device must accept any interference received, including interference that may cause undesired operation.

IMPORTANT NOTE: FCC Radiation Exposure Statement:

This equipment complies with FCC radiation exposure limits set forth for an uncontrolled environment.

Industry Canada

Note: You must place "Contains IC ID: 3147A-BT800" on the host product in such a location that it can be seen by an operator at the time of purchase.

RF Radiation Hazard Warning

Using higher gain antennas and types of antennas not certified for use with this product is not allowed. The device shall not be co-located with another transmitter.

Cet avertissement de sécurité est conforme aux limites d'exposition définies par la norme CNR-102 at relative aux fréquences radio.

This radio transmitter (Contains IC ID: 3147A-BT800) has been approved by Industry Canada to operate with the antenna types listed in table above with the maximum permissible gain and required antenna impedance for each antenna type indicated. Antenna types not included in this list, having a gain greater than the maximum gain indicated for that type, are strictly prohibited for use with this device.

Le présent émetteur radio (Contains IC ID: 3147A-BT800) a été approuvé par Industrie Canada pour fonctionner avec les types d'antenne énumérés ci-dessous et ayant un gain admissible maximal et l'impédance requise pour chaque type d'antenne. Les types d'antenne non inclus dans cette liste, ou dont le gain est supérieur au gain maximal indiqué, sont strictement interdits pour l'exploitation de l'émetteur.

Under Industry Canada regulations, this radio transmitter may only operate using an antenna of a type and maximum (or lesser) gain approved for the transmitter by Industry Canada. To reduce potential radio interference to other users, the antenna type and its gain should be so chosen that the equivalent isotropically radiated power (e.i.r.p.) is not more than that necessary for successful communication.

Conformément à la réglementation d'Industrie Canada, le présent émetteur radio peut fonctionner avec une antenne d'un type et d'un gain maximal (ou inférieur) approuvé pour l'émetteur par Industrie Canada. Dans le but de réduire les risques de brouillage radioélectrique à l'intention des autres utilisateurs, il faut choisir le type d'antenne et son gain de sorte que la puissance isotrope rayonnée équivalente (p.i.r.e.) ne dépasse pas l'intensité nécessaire à l'établissement d'une communication satisfaisante.

This device complies with Industry Canada license-exempt RSS standard(s). Operation is subject to the following two conditions: (1) this device may not cause interference, and (2) this device must accept any interference, including interference that may cause undesired operation of the device.

Le présent appareil est conforme aux CNR d'Industrie Canada applicables aux appareils radio exempts de licence. L'exploitation est autorisée aux deux conditions suivantes : (1) l'appareil ne doit pas produire de brouillage, et (2) l'utilisateur de l'appareil doit accepter tout brouillage radioélectrique subi, même si le brouillage est susceptible d'en compromettre le fonctionnement.

16 EUROPEAN UNION REGULATORY

The BT800 has been tested for compliance with relevant standards for the EU market. BT800 module was tested with a 0.5 dBi chip antenna.

The OEM should consult with a qualified test house before entering their device into an EU member country to make sure all regulatory requirements have been met for their complete device.

Reference the Declaration of Conformities listed below for a full list of the standards that the modules were tested to. Test reports are available upon request.

16.1. EU Declarations of Conformity

Manufacturer:	Laird	
Products:	BT800, BT810, BT820	
	BT800, BT800-ST	BTv4.0 Dual Mode USB HCI Module
Product Description	BT810	BTv4.0 Dual Mode USB HCI Module (BG carrier board)
	BT820	BTv4.0 Dual Mode USB Dongle
EU Directives:	2014/53/EU – Radio Equipment Directive (RED)	



Reference standards used for presumption of conformity:

Article Number	Requirement	Reference standard(s)
3.1a	Low voltage equipment safety	EN 60950-1:2006 +A11:2009 +A1:2010 +A12:2011 +A2:2013
	RF Exposure	EN 62311:2008 EN 62479:2010
3.1b	Protection requirements with respect to electromagnetic compatibility	EN 301 489-1 v2.2.0 (2017-03) EN 301 489-17 v3.2.0 (2017-03)
3.2	Means of the efficient use of the radio frequency spectrum	EN 300 328 v2.1.1 (2016-11)

Declaration:

We, Laird, declare under our sole responsibility that the essential radio test suites have been carried out and that the above product to which this declaration relates is in conformity with all the applicable essential requirements of Article 3 of the EU Directive 1999/5/EC, when used for its intended purpose.

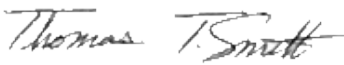
Place of Issue:	Laird W66N220 Commerce Court, Cedarburg, WI 53012 USA tel: +1-262-375-4400 fax: +1-262-364-2649
Date of Issue:	May 2017
Name of Authorized Person:	Thomas T Smith, Director of EMC Compliance
Signature of Authorized Person:	

17 ORDERING INFORMATION

Part Number	Description
BT800	BTv4.0 Dual Mode USB HCI Module
BT820	BTv4.0 Dual Mode USB Dongle
DVK-BT800	Development Kit for BT800 Module

17.1. General Comments

This is a preliminary datasheet. Please check with Laird for the latest information before commencing a design. If in doubt, ask.

18 BLUETOOTH SIG APPROVALS

18.1. Application Note: Subsystem Combinations

This application note covers the procedure for generating a new Declaration ID for a Subsystem combination on the Bluetooth SIG website. In the instance of subsystems, a member can combine two or more subsystems to create a complete Bluetooth End Product solution.

Subsystem listings referenced as an example:

Design Name	Owner	Declaration ID	Link to listing on the SIG website
BT800-SA	Laird	B021369	https://www.bluetooth.org/tpg/QLI_viewQDL.cfm?qid=21369
Windows 8 (Host Subsystem)	Microsoft Corporation	B012854	https://www.bluetooth.org/tpg/QLI_viewQDL.cfm?qid=12854

Laird Customer Declaration ID Procedure

This procedure assumes that the member is simply combining two subsystems to create a new design, without any modification to the existing, qualified subsystems. This is achieved by using the Listing interface on the Bluetooth SIG website. [Figure 26](#) shows the basic subsystem combination of a controller and host subsystem. The Controller provides the RF/BB/LM and HCI layers, with the Host providing L2CAP, SDP, GAP, RFCOMM/SPP and any other specific protocols and profiles existing in the Host subsystem listing. The design may also include a Profile Subsystem.

The controller provides the RF/BB/LM and HCI layers, with the Host providing L2CAP, SDP, GAP, RFCOMM/SPP and any other specific protocols and profiles existing in the Host subsystem listing. The design may also include a Profile Subsystem.

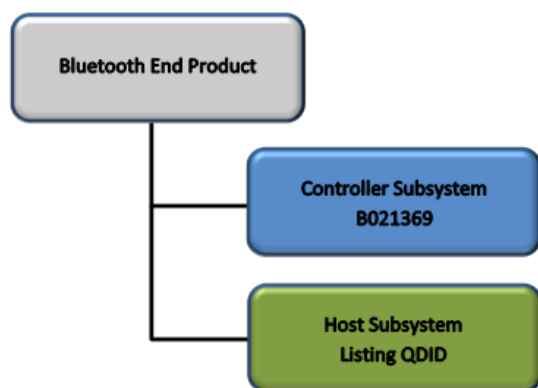

Figure 26: Basic subsystem combination of a controller and host subsystem

The Qualification Process requires each company to registered as a member of the Bluetooth SIG – <http://www.bluetooth.org>

The following link provides a link to the Bluetooth Registration page: <https://www.bluetooth.org/login/register/>

For each Bluetooth Design it is necessary to purchase a Declaration ID. This can be done before starting the new qualification, either through invoicing or credit card payment. The fees for the Declaration ID will depend on your membership status, please refer to the following webpage:

<https://www.bluetooth.org/en-us/test-qualification/qualification-overview/fees>

For a detailed procedure of how to obtain a new Declaration ID for your design, please refer to the following SIG document:

https://www.bluetooth.org/DocMan/handlers/DownloadDoc.ashx?doc_id=283698&vId=317486

To start the listing, go to: https://www.bluetooth.org/tpg/QLI_SDoc.cfm.

In step 1, select the option, **Reference a Qualified Design** and enter the Declaration IDs of each subsystem used in the End Product design. You can then select your pre-paid Declaration ID from the drop down menu or go to the Purchase Declaration ID page, (please note that unless the Declaration ID is pre-paid or purchased with a credit card, it will not be possible to proceed until the SIG invoice is paid.

Once all the relevant sections of step 1 are finished, complete steps 2, 3, and 4 as described in the help document. Your new Design will be listed on the SIG website and you can print your Certificate and DoC.

For further information please refer to the following training material:

<https://www.bluetooth.org/en-us/test-qualification/qualification-overview/listing-process-updates>

19 ADDITIONAL ASSISTANCE

Please contact your local sales representative or our support team for further assistance:

Laird Technologies Connectivity Products Business Unit

Support Centre: <http://ews-support.lairdtech.com>

Email: wireless.support@lairdtech.com

Phone: Americas: +1-800-492-2320

Europe: +44-1628-858-940

Hong Kong: +852 2923 0610

Web: <http://www.lairdtech.com/bluetooth>

© Copyright 2017 Laird. All Rights Reserved. Patent pending. Any information furnished by Laird and its agents is believed to be accurate and reliable. All specifications are subject to change without notice. Responsibility for the use and application of Laird materials or products rests with the end user since Laird and its agents cannot be aware of all potential uses. Laird makes no warranties as to non-infringement nor as to the fitness, merchantability, or sustainability of any Laird materials or products for any specific or general uses. Laird, Laird Technologies, Inc., or any of its affiliates or agents shall not be liable for incidental or consequential damages of any kind. All Laird products are sold pursuant to the Laird Terms and Conditions of Sale in effect from time to time, a copy of which will be furnished upon request. When used as a tradename herein, *Laird* means Laird PLC or one or more subsidiaries of Laird PLC. Laird™, Laird Technologies™, corresponding logos, and other marks are trademarks or registered trademarks of Laird. Other marks may be the property of third parties. Nothing herein provides a license under any Laird or any third party intellectual property right.

Mouser Electronics

Authorized Distributor

Click to View Pricing, Inventory, Delivery & Lifecycle Information:

Laird:

[DVK-BT800](#) [BT800](#) [DVK-BT800-02](#) [BT800-ST-T/R](#)