

THIS DOCUMENT IS THE PROPERTY OF
KEYSTONE ELECTRONICS CORP. AND
SHALL NOT BE REPRODUCED, DISTRIBUTED
OR USED AS A BASIS FOR MANUFACTURE
WITHOUT PRIOR WRITTEN PERMISSION
FROM KEYSTONE ELECTRONICS CORP.

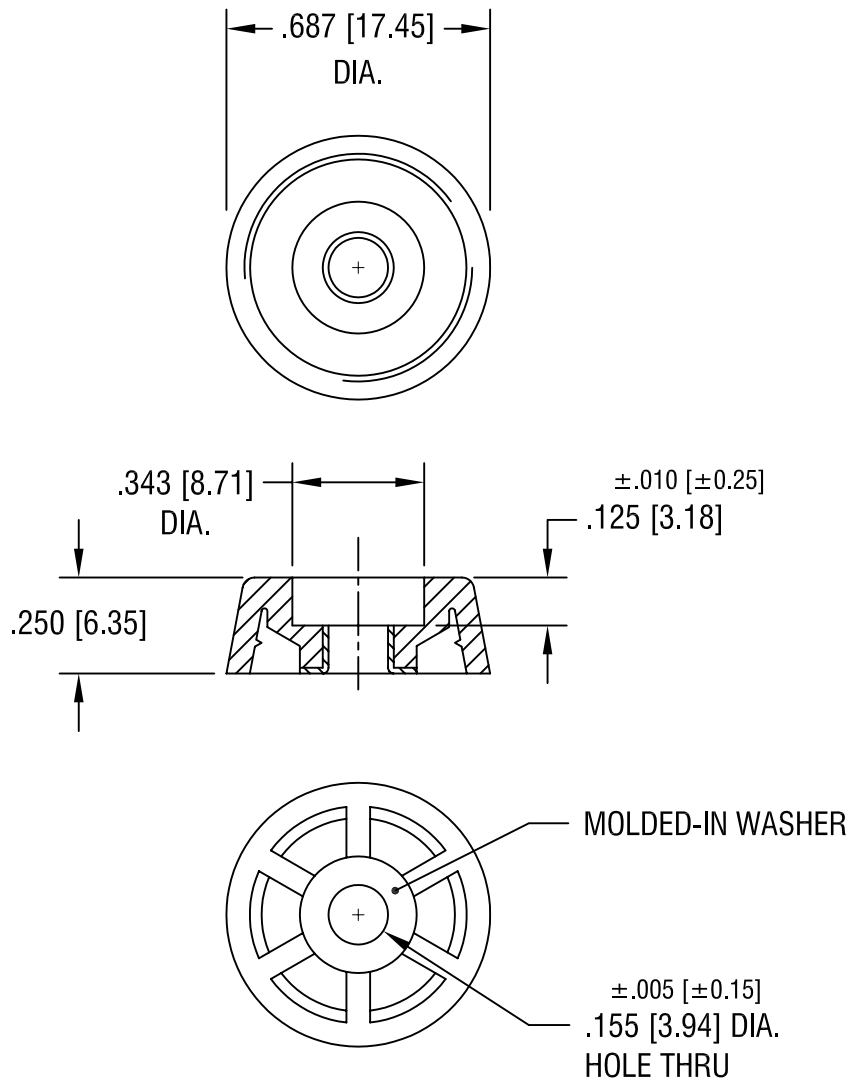

NOTES:

- 1. BODY: MAT'L - THERMOPLASTIC RUBBER, GREY
WASHER: MAT'L - STEEL, ZINC PLATE

KEYSTONE ELECTRONICS CORP.			
ASTORIA, N.Y. 11105-2017			
PART NAME		RECESSED BUMPER	
MATERIAL		AS NOTED	
FINISH	AS NOTED	DRN BY	BOONE
		DATE	11.26.96
		APP'D	LN
		SCALE	2X
TOLERANCES	INCH [MM]	CODE	DWG NO.
DECIMAL	±.020 [±0.50]	C/M	724
ANGULAR	± 1°		
UNLESS OTHERWISE SPECIFIED			

5.7.07	CHANGE AS PER ECN 07-021	A
DATE	DESCRIPTION	REV.

Mouser Electronics

Authorized Distributor

Click to View Pricing, Inventory, Delivery & Lifecycle Information:

[Keystone Electronics:](#)

[724](#)