

Overview

KEMET's QMS thin film digital pyroelectric IR sensors combine high sensitivity with fast response times to ensure rapid and accurate motion detection, and high dynamic range to allow motion detection nearby or over larger distances. The 2x2 pixel version of this device allows users to determine direction of motion.

These high quality sensors, in their small SMD package, integrate a digital, current mode read-out. Industry standard I²C communication enables plug-and-play connectivity to microcontrollers and allows easy tuning. Programmable gain and filtering offer maximum flexibility in system design, and various low power modes, including a wake-up by motion feature, are also available. These sensors can be connected together in linear series to allow synchronized sampling across devices.

For additional sources of information, please refer to <https://ec.kemet.com/environmental-sensors/>

Benefits

- High sensitivity with fast response time
- High dynamic range
- Small SMD package
- I²C communication
- Digital output
- Programmable gain and filtering
- Various pixel and aperture configurations
- Ultra-low power consumption and standby modes, motion triggered wake-up
- Sensor modules and evaluation kits available for easy evaluation and quick prototype development (ref QMSM Series)

Applications

- Contactless switching
- Office automation equipment
- Home appliances
- Lighting
- Display products
- Air-conditioners
- TV
- PC monitors
- Rice cookers
- Smart toilets

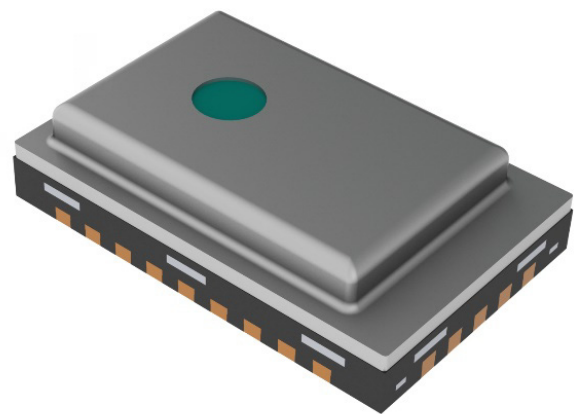
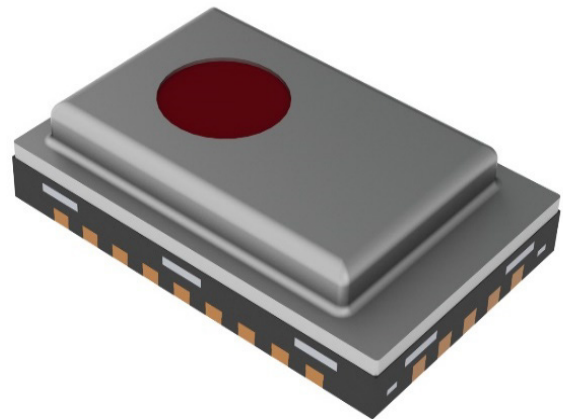

Ordering Information

USE	QMS	E	A	0116	8	0
Product Family	Series	Sensor Type	Mounting Type	Specification	Packaging	Version
Sensors	QMS = SMD IR Motion Sensors	E = Serial output	A = Sensor only	0116 = 1x1 pixel, 1.65 aperture, 5.0 μm Long Pass 2216 = 2x2 pixel, 1.65 aperture, 5.0 μm Long Pass 2209 = 2x2 pixel, 0.9 aperture, 5.0 μm Long Pass	8 = 7" Tape & Reel	0

Environmental Compliance

All KEMET Motion Sensors are RoHS and REACH Compliant.



Article 33(1) of the REACH Regulation states that manufacturers and importers of articles (products) are required to notify their customers of the presence of any Substances of Very High Concern (SVHC) in their products exceeding 0.1% by weight and provide instructions on safe use of the product.

KEMET Corporation reports regarding the Article 33(1) of REACH Regulation as follows:

1. *Applicable Product: Motion Sensors (QMS and QMSM series)*

2. *Report for the content of REACH SVHC list:*

The product(s) above contains a substance by more than 0.1wt% per product weight that was published in the 8th update of the REACH SVHC substances (December 19, 2012).

3. *Regarding the safety of the motion sensors (Piezoceramic products):*

The Piezoceramic that is used in this product becomes ceramic by sintering powder containing PZT as the main ingredient. It is chemically stable, with minimum risks toward the human body or environment within the intended use of the product. Please note that risks could occur in the case of inhalation or accidental oral uptake of powder ceramics.

4. *Technical product information on the motion sensors (Piezoceramic products):*

The manufacturing technique of the "piezoceramic products" whose main ingredient is Lead Titanium Zirconium Oxide (PZT) has been established, and there is no alternative material that can exhibit superior performance than PZT at this moment. Please note that the piezoceramic is listed as an exempt on RoHS (2011/65/EU) AnnexIII (7c.1).

5. *The responsibility of piezoceramic manufacturers:*

Piezoceramic manufacturers report information regarding PZT containment in their products to the customers to obey the article 33 of the REACH regulation

Dimensions – Millimeters

Sensor

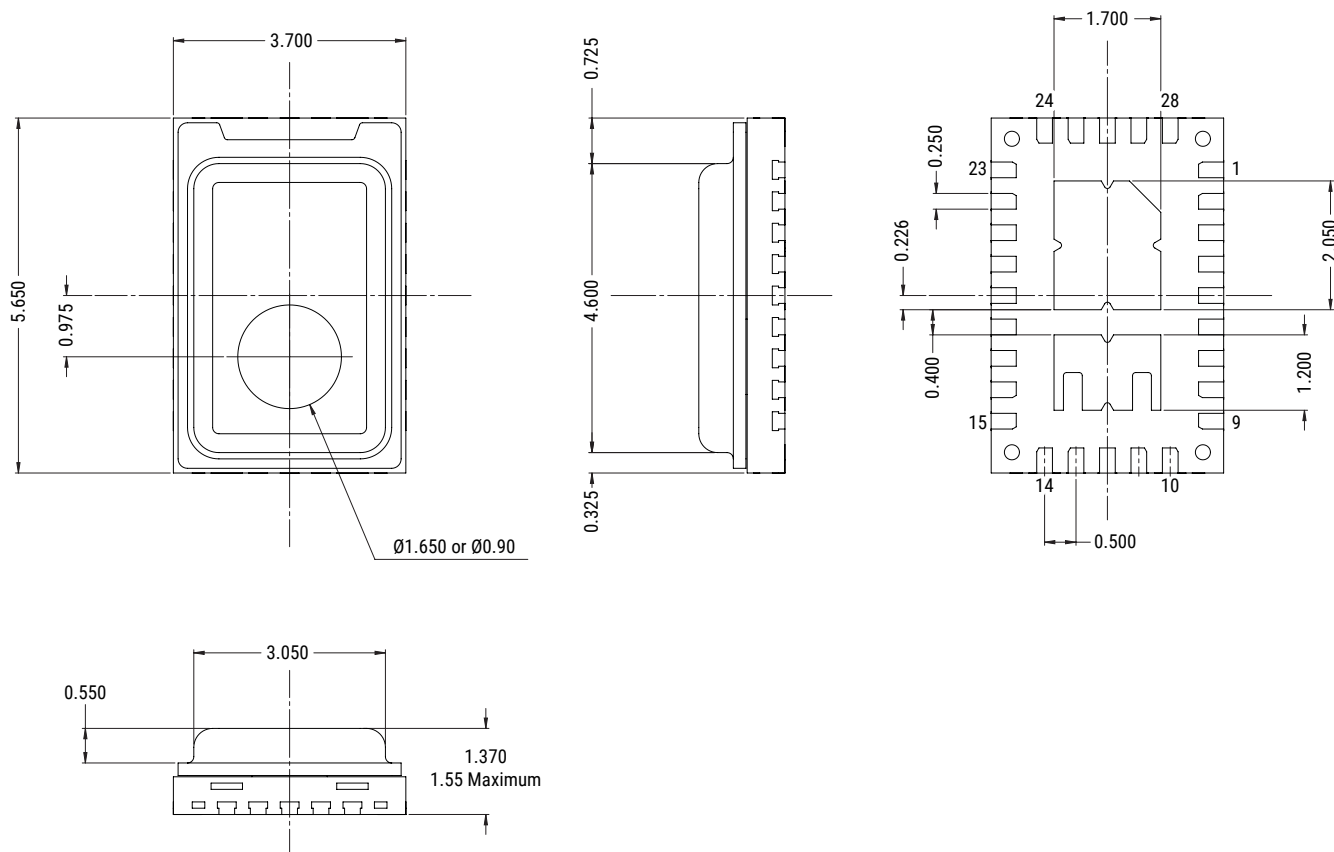

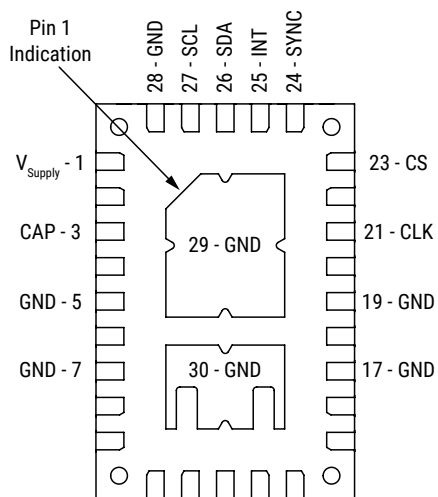

Pin Configuration of the Sensor



Transparent Top View

Field of View

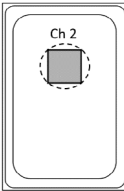
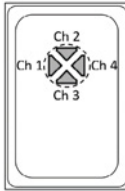
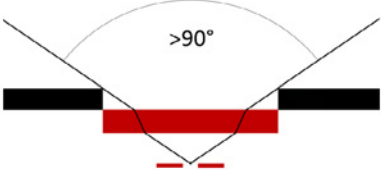
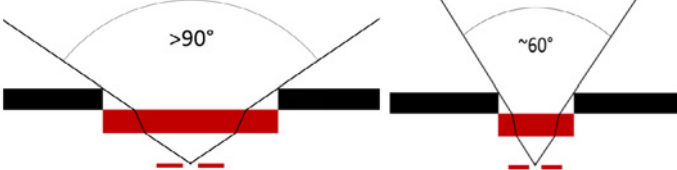
	Single Element	2x2 Array
Sensor Element		
Pixel Mapping		
Field of View		 <div style="display: flex; justify-content: space-around; width: 100%;"> Large Aperture Small Aperture </div>

Circuit Diagram

Single Device Block Diagram - Single Element

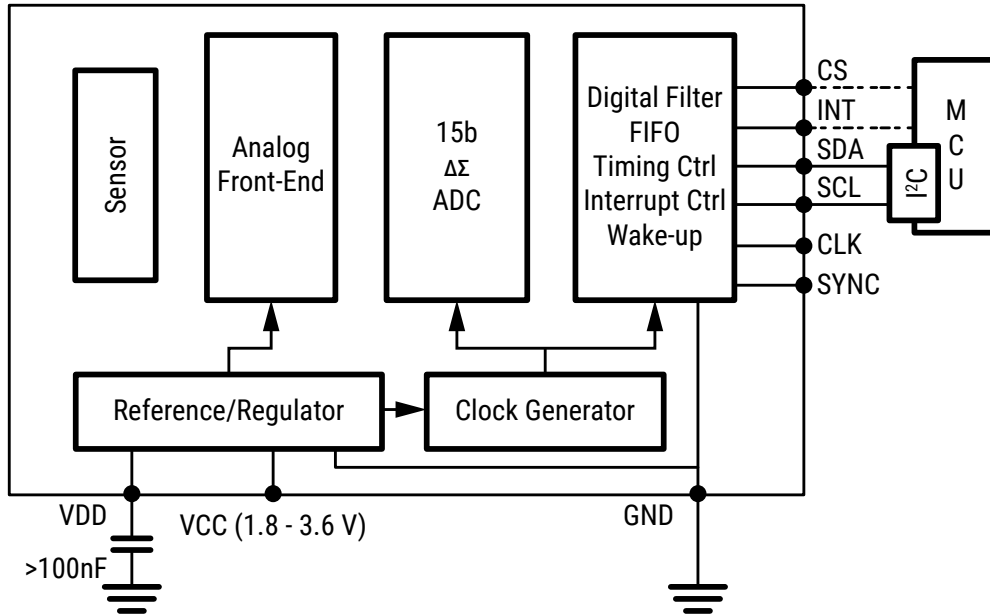

Single Device Block Diagram - 2 x 2 Pixel

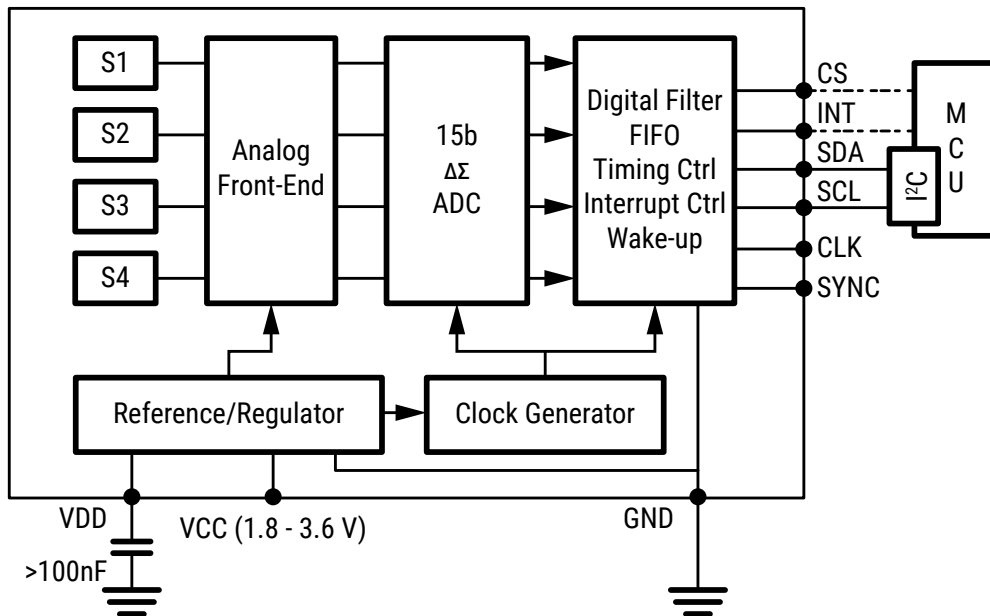

Circuit Diagram cont.

Three Devices with Synchronised Sampling

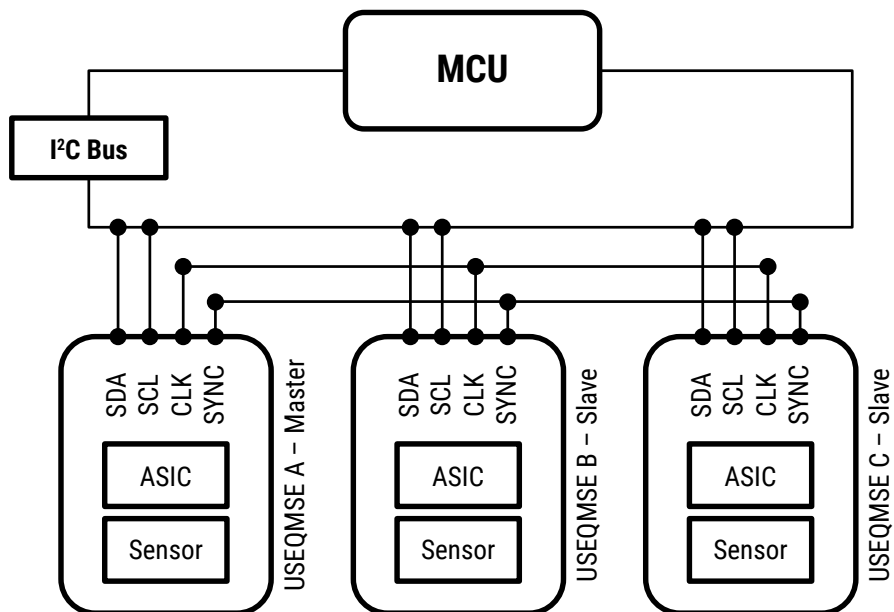

Recommended Circuit Diagram

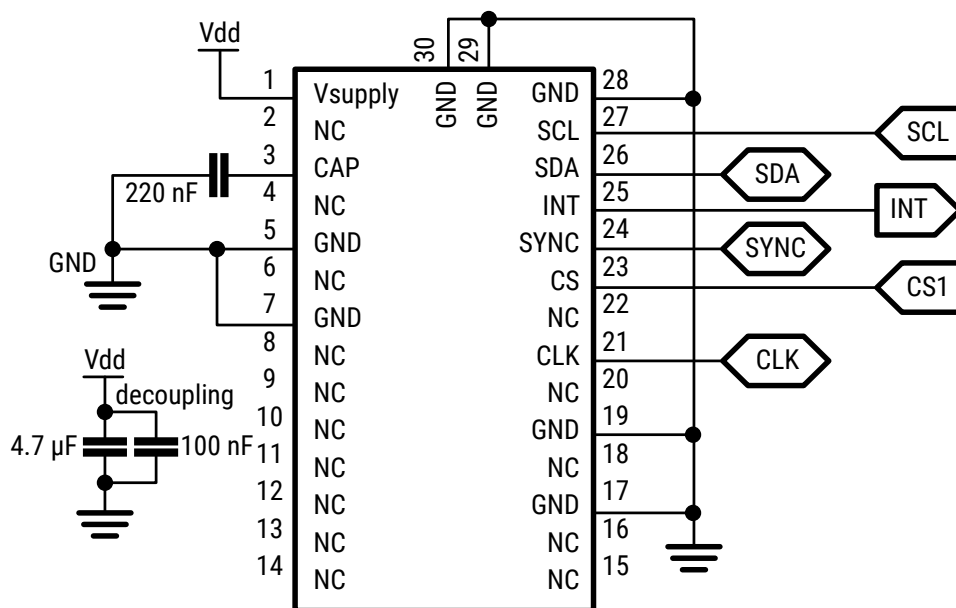

Performance Characteristics

Signal Filtering & Power Modes

Power Mode (base sample rate)	High Pass Filter – Analog (Hz)					Fixed Analog Low Pass Filter (Hz)	Fixed Digital Low Pass Filter (Hz)	Digital Low Pass Filter (Hz)				Maximum ADC Sampling Rate (sps)
	Off	1.0	2.0	4.0	8.0			180.0	90.0	45.0	22.5	
Normal Power Mode	Off	1.0	2.0	4.0	8.0	600	250	180.0	90.0	45.0	22.5	1,000
Low Power Mode	Off	0.17	0.33	0.66	1.30	100	42	30.00	15.00	7.50	3.75	166

Item	Mode	Description	Typical Current Consumption (1.8 V, room temperature)
Power consumption	Normal Power Mode	Normal power consumption, 1 kHz maximum sample rate	22 μ A
	Low Power Mode	Low power consumption, 166 Hz maximum sample rate	3.5 μ A
Operational state	Normal Operation Mode	Sensor signal readout over I ² C	22 μ A
	Sleep Mode	Hardware interrupt on infrared trigger	21 μ A (Normal Power Mode) 3.5 μ A (Low Power Mode)
	Power Down Mode	Sensor is disabled	1.1 μ A

Infrared Frequency Characteristics

Typical Frequency Response in Normal Power Mode

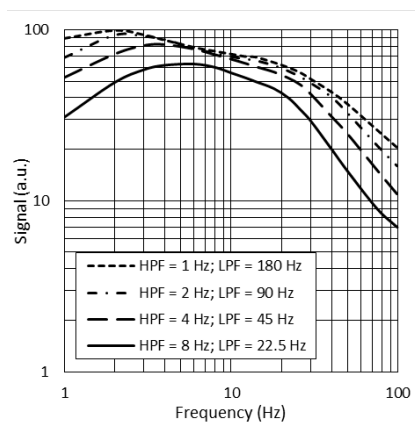

Typical Frequency Response in Low Power Mode

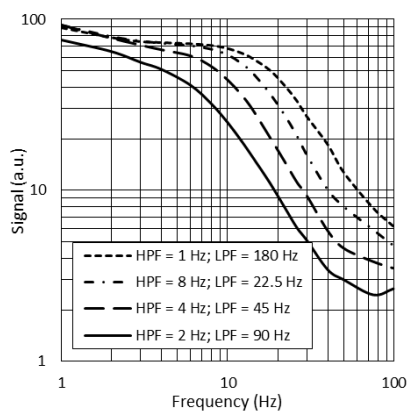

Typical Frequency Response at Different Gain Settings

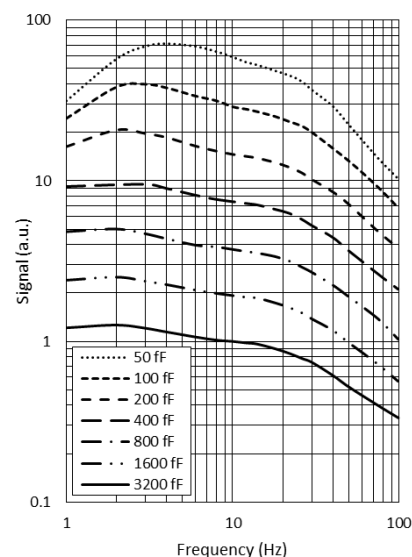

Part Number Specifications

Electrical Characteristics

Supply Voltage (V)	Supply Current (μA) Typical	Digital I/O	ΔΣ ADC at 1 ksp	Operating Temperature Range (°C)	Storage Temperature Range (°C)	Sensor Read-out	Configurable
1.75 to 3.60	1 to 23	I ² C (FM+ compatible)	15 bit	-40 to +85	-40 to +110	Current mode	Gain Digital filtering Sampling rate Power modes

Part Number (Sensor)

Part Number	Filter Aperture (mm)	Element Size (mm ²)	SMD Package (mm)	D*1 (cm√Hz/W) Typical	NEP ¹ (W/√Hz) Typical	Time Constant (ms) at 10–20 Hz peak	Filter	Weight (gr)
USEQMSEA011680	φ 1.65	0.410 (1 pixel)	5.65 x 3.70 x 1.55	2.5 x 10 ⁸	2.7 x 10 ⁻¹⁰	~10	5.0 μm Long Pass	0.07
USEQMSEA221680	φ 1.65	4 x 0.057 (4 pixel)		5.5 x 10 ⁸	0.4 x 10 ⁻¹⁰			0.07
USEQMSEA220980	φ 0.90	4 x 0.057 (4 pixel)		0.07				

¹ 10 Hz, 500 K, room temperature, without window and optics.

Landing Pattern

Recommended PCB Landing Pattern - Millimeters

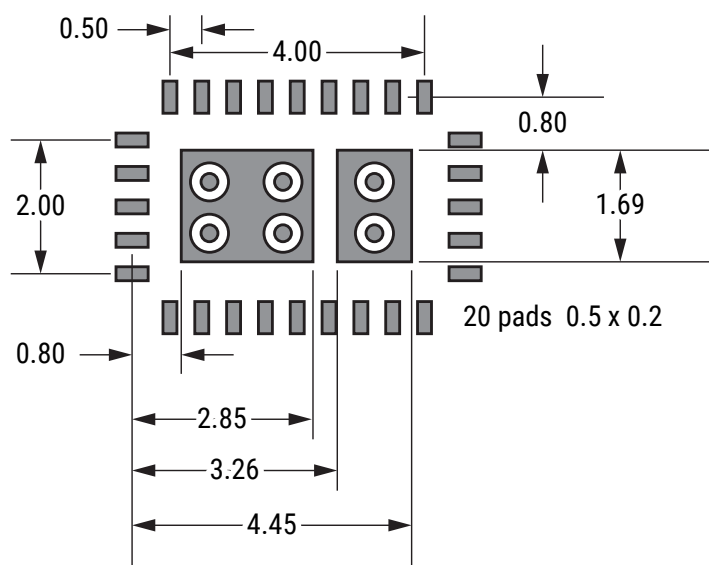

Soldering Process

Recommended Reflow Soldering Profile

Profile Feature	Pb-Free Assembly
Preheat/Soak	
Temperature Minimum (T_{smin})	150°C
Temperature Maximum (T_{smax})	200°C
Time (t_s) from T_{smin} to T_{smax}	60 – 120 seconds
Ramp-Up Rate (T_L to T_p)	3°C/second maximum
Liquidous Temperature (T_L)	217°C
Time Above Liquidous (t_L)	60 – 150 seconds
Peak Temperature (T_p)	260°C
Time within 5°C of Maximum Peak Temperature (t_p) ¹	30 seconds maximum
Ramp-Down Rate (T_p to T_L)	6°C/second maximum
Time 25°C to Peak Temperature	8 minutes maximum

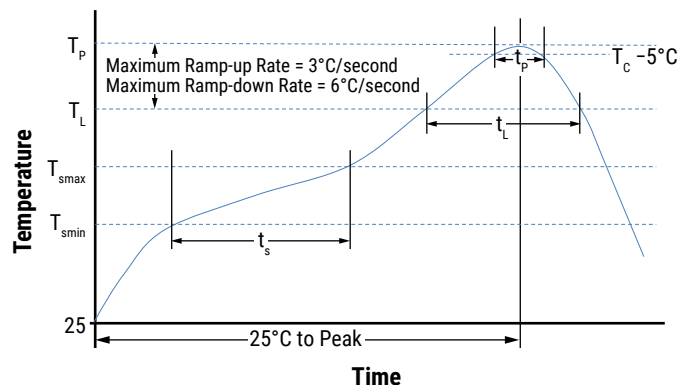

¹ Tolerance for peak profile temperature (TP) is defined as a supplier minimum and as a user maximum.

Packaging

Series	Packaging Type	Pieces per Reel
QMS	7" Tape & Reel	800

Taping Specification

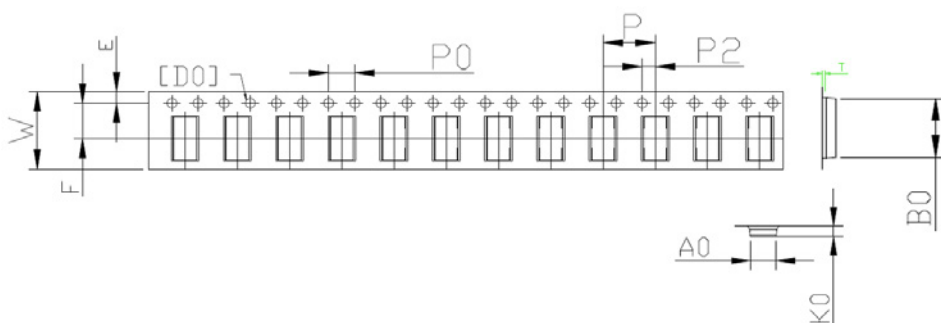

	Dimensions (mm)										
	P0	P	T	P2	W	A0	B0	K0	E	F	D0
Minimum	3.90	7.90	0.25	1.90	11.70	3.90	5.85	1.65	1.65	5.40	1.50
Typical	4.00	8.00	0.30	2.00	12.00	4.00	5.95	1.75	1.75	5.50	1.50
Maximum	4.10	8.10	0.35	2.10	12.30	4.10	6.05	1.85	1.85	5.60	1.60

Reel Specification

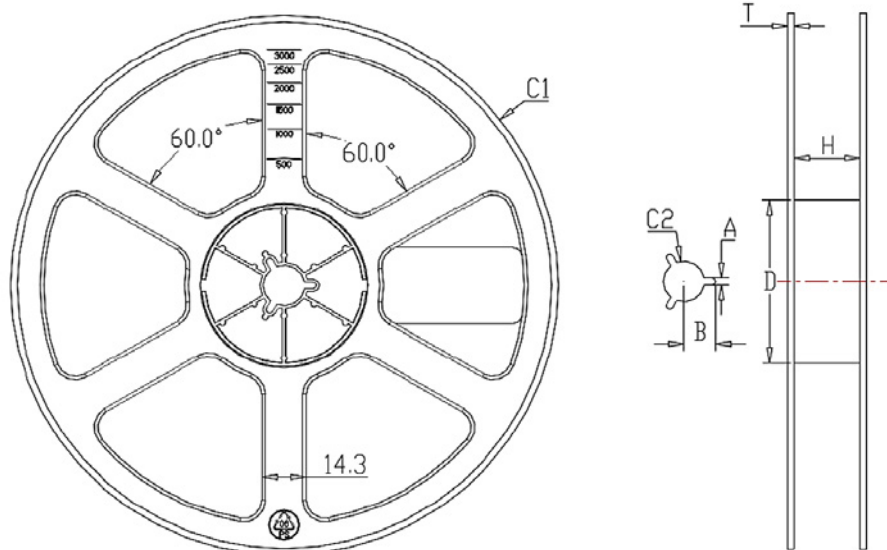

	Dimensions (mm)						
	C1	C2	A	B	H	T	D
Tolerance	±1.0	±0.2	±0.2	±0.2	±0.5	±0.2	±0.5
Nominal	Ø178	13.5	2.3	10.4	12.5	1.6	Ø54

Handling Precautions

Pyroelectric Infrared Sensors should be kept away from indirect and direct sunlight, the headlights of cars, wind, and exposure to strong vibration and strong shock.

Do not use in water, alcohol ETA, corrosive gas or under sea breeze.

Do not expose to corrosive substances.

Do not drop or apply any mechanical stress.

The performance of this device can be affected by ESD. Precautions should be used when handling and installing the sensor. Precision devices such as this sensor can be damaged or caused not to meet published specification due to ESD. Please note that there is limited ESD protection built-in as the device is optimised for low power consumption and low noise operation. Human Body Model (HBM), per JS-001: 2,000 V.

The sensor is classed as Moisture Sensitivity Level 3 (MSL-3). The package should be handled according to IPC/JEDEC J-STD-20.

Pyroelectric Infrared Sensors should be stored in normal working environments.

Solderability will be degraded by exposure to high temperatures, high humidity, corrosive atmospheres, and long-term storage.

KEMET recommends that ambient storage conditions are < 30°C and < 60% relative humidity and that maximum storage temperature does not exceed 110°C. Atmospheres should be free of chlorine and sulfur-bearing compounds.

Temperature fluctuations should be minimized to avoid condensation on the parts.

For optimized solderability sensors stock should be used promptly, preferably within 24 months of receipt.

KEMET Electronics Corporation Sales Offices

For a complete list of our global sales offices, please visit www.kemet.com/sales.

Disclaimer

All product specifications, statements, information and data (collectively, the "Information") in this datasheet are subject to change. The customer is responsible for checking and verifying the extent to which the Information contained in this publication is applicable to an order at the time the order is placed. All Information given herein is believed to be accurate and reliable, but it is presented without guarantee, warranty, or responsibility of any kind, expressed or implied.

Statements of suitability for certain applications are based on KEMET Electronics Corporation's ("KEMET") knowledge of typical operating conditions for such applications, but are not intended to constitute – and KEMET specifically disclaims – any warranty concerning suitability for a specific customer application or use. The Information is intended for use only by customers who have the requisite experience and capability to determine the correct products for their application. Any technical advice inferred from this Information or otherwise provided by KEMET with reference to the use of KEMET's products is given gratis, and KEMET assumes no obligation or liability for the advice given or results obtained.

Although KEMET designs and manufactures its products to the most stringent quality and safety standards, given the current state of the art, isolated component failures may still occur. Accordingly, customer applications which require a high degree of reliability or safety should employ suitable designs or other safeguards (such as installation of protective circuitry or redundancies) in order to ensure that the failure of an electrical component does not result in a risk of personal injury or property damage.

Although all product-related warnings, cautions and notes must be observed, the customer should not assume that all safety measures are indicated or that other measures may not be required.

When providing KEMET products and technologies contained herein to other countries, the customer must abide by the procedures and provisions stipulated in all applicable export laws and regulations, including without limitation the International Traffic in Arms Regulations (ITAR), the US Export Administration Regulations (EAR) and the Japan Foreign Exchange and Foreign Trade Act.

KEMET is a registered trademark of KEMET Electronics Corporation.

Mouser Electronics

Authorized Distributor

Click to View Pricing, Inventory, Delivery & Lifecycle Information:

KEMET:

[USEQMSM1011600](#) [USEQMSEA220980](#) [USEQMSM1220900](#) [USEQMSEA011680](#) [USEQMSKL221600](#)
[USEQMSKS221600](#) [USEQMSM1221600](#) [USEQMSKL011600](#) [USEQMSEA221680](#) [USEQMSK1220900](#)