

Tilt Sensor Switch

Item No.	RBS152100T	Description	Ball-Contact	Version	12
Page	1 of 8		Publish Date	Jul. 03, 2018	

● FUNCTIONS

One Axis 15° Tilt Detecting in horizontal position

● APPLICATIONS

1. Wake up systems for power saving, such like remote controllers.
2. One Axis 15° tilt Detecting in horizontal position installed above or under PCB.

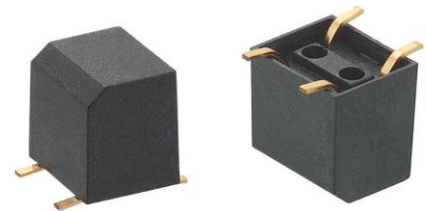

● FEATURES

1. Suitable for horizontal PCB.
2. Switch state: SMD Normal Open.
3. Housing made of high insulation plastic material, free from electric conduction and rust problem.
4. Gold-plated ball and terminals, low possibility of oxidization.
5. All plastic materials subject to industrial purpose, resist high temperature and meet fireproof function.
6. Simple ON and OFF signals, easy for design.
7. RoHS compliance, an ideal substitute for mercury switch.
8. A more economical tilt detection option than IC design solution.
9. All made in Taiwan and examined before shipment.

● PATENTS

1. U.S.A. Patent No. US 7,176,396 B1
2. Taiwan Patent No. I 297161
3. China Patent No. ZL 200610072563.7



Tilt Sensor Switch

Item No.	RBS152100T	Description	Ball-Contact	Version	12
Page	2 of 8		Publish Date	Jul. 03, 2018	

● DIMENSIONS / OPERATION / P.C.B. LAYOUT (Unit: mm, Tolerance: ±0.25mm)

Fig. 1

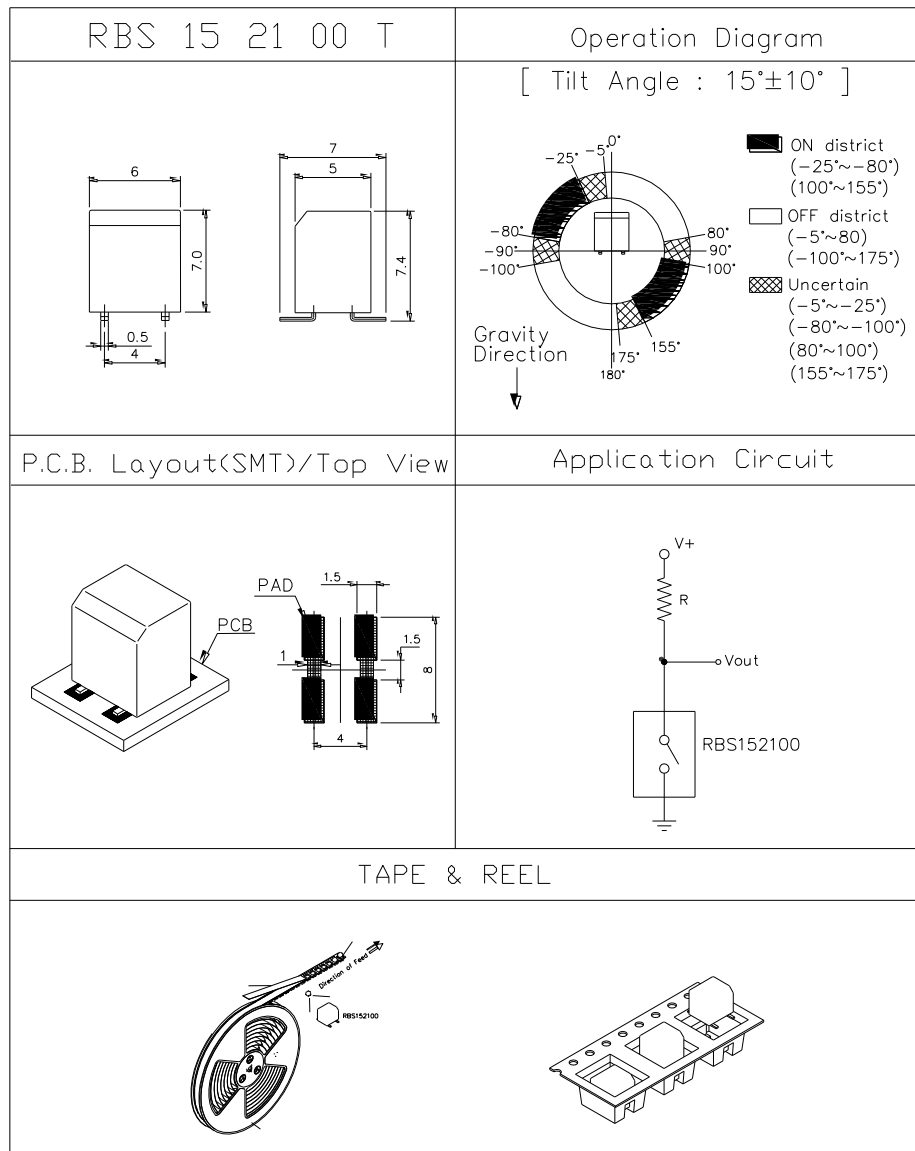

Tilt Sensor Switch

Item No.	RBS152100T	Description	Ball-Contact	Version	12
Page	3 of 8		Publish Date	Jul. 03, 2018	

● Current/Voltage Suggested

Input Current (mA)	Operating Voltage (V)	Condition
1.0	5	--

● ELECTRICAL CHARACTERISTICS

1.	Contact Rating	10 mA, 5VDC
2.	Contact Resistance	10Ω max.
3.	Operation Diagram	Refer to Fig. 1
4.	Insulation Resistance	10 MΩ min. at 100VDC
5.	Dielectric Strength	500VDC min. for 1 minute
6.	Capacitance	5pF max.
7.	Conductive Rate	90% min.



Tilt Sensor Switch

Item No.	RBS152100T	Description	Ball-Contact	Version	12
Page	4 of 8		Publish Date	Jul. 03, 2018	

● RELIABLE TEST ITEMS

Reliable Test for RBS152100T

	Test Item	Contents
1	IR Reflow	Peak temp.=255~260°C
2	Operating Temperature	-25°C ~ 85°C
3	Storage Temperature	-40°C ~ 85°C
4	Humidity	40°C / 95%RH
5	Mechanical Life	2 Hz horizontal 1,000,000 times
6	Electrical Life	100,000 times

● SOLDERING CONDITION

Following soldering conditions are for reference only, please use soldering information that solder paste manufacturer recommends.

Condition	Soldering Temperature	Soldering Time	Wattage of Manual Soldering	Type
Suitable Production Process				
IR Reflow	Please refer to following < Table of classification Reflow profile > and Fig. 2		-	SMD
Manual Soldering	300±5°C	< 3 seconds max.	30W or Temperature-controlled manual soldering	SMD



Tilt Sensor Switch

Item No.	RBS152100T	Description	Ball-Contact	Version	12
Page	5 of 8		Publish Date	Jul. 03, 2018	

< Table of classification Reflow profile >

Item	Pb process	Pb free process
Pre-heat and Soak		
Temperature min.(T _{min})	100°C	150°C
Temperature max.(T _{max})	150°C	200°C
Time (T _{min} to T _{max})(t _s)	60-120 seconds	60-120 seconds
Average Rate of temperature rising up (T _{max} to T _p)	3°C/second max.	3°C/second max.
Liquidous Temperature (T _L)	183°C	217°C
Time at Liquidous (t _L)	60-150 seconds	60-150 seconds
Peak package body Temperature (T _p)*	230°C ~235°C *	255°C ~260°C *
Classification temperature(T _c)	235°C	260°C
Time(tp)** within 5 °C of the specified classification temperature (T _c)	20** seconds	30** seconds
Average ram-down Rate (T _p to T _{max})	6°C/second max.	6°C/second max.
Time 25 °C to peak temperature	6 minutes max.	8 minutes max.
* Tolerance for peak profile temperature (T _p) is defined as a supplier minimum and a user maximum.		
** Tolerance for time at peak profile temperature (tp) is defined as a supplier minimum and a user maximum.		



Tilt Sensor Switch

Item No.	RBS152100T	Description	Ball-Contact	Version	12
Page	6 of 8		Publish Date	Jul. 03, 2018	

Fig. 2

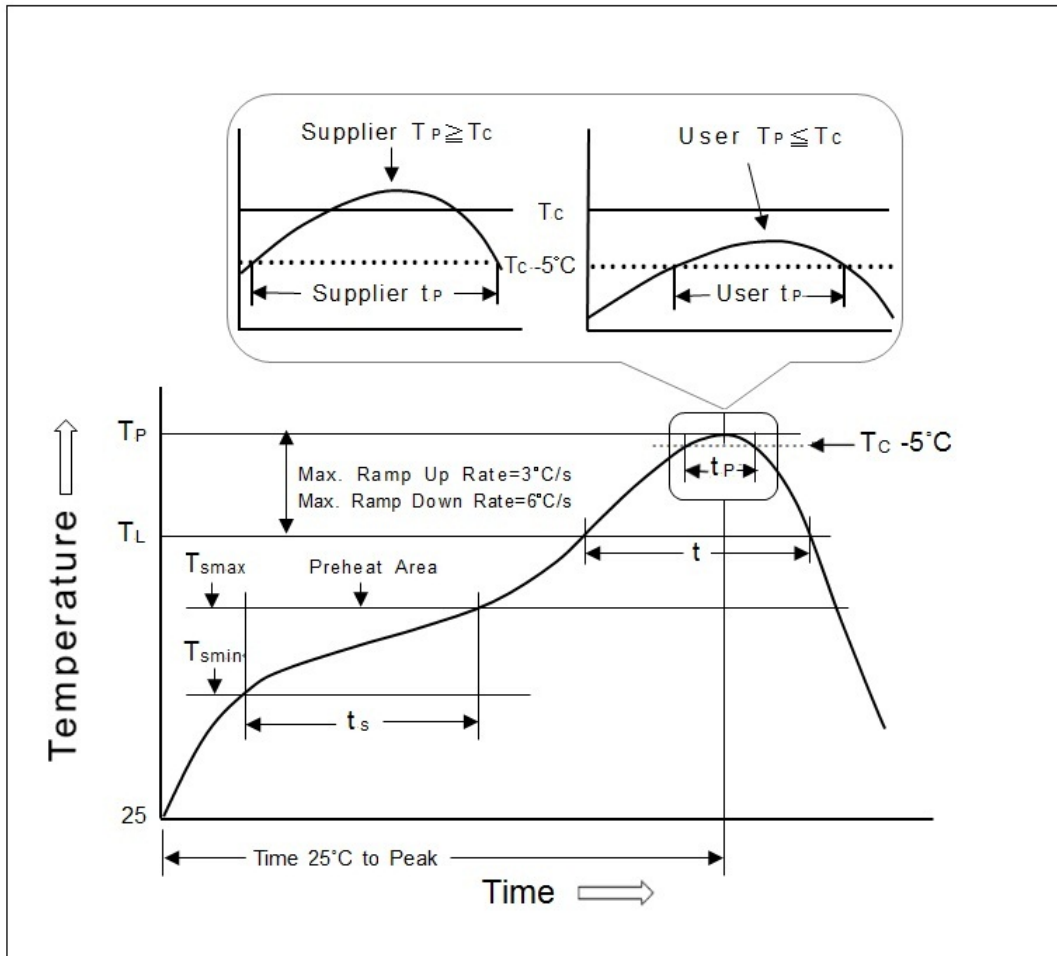

Tilt Sensor Switch

Item No.	RBS152100T	Description	Ball-Contact	Version	12
Page	7 of 8		Publish Date	Jul. 03, 2018	

● PACKAGE

	Part Number	Package	Quantity	Total	Dimension (mm)
1.	RBS152100T	Tape & reel	700 pcs	700 pcs	φ330*17H
		Inner box	2 Reels	1,400 pcs	355L*340W*68H
		Carton	10 boxes	14,000 pcs	703L*364W*380H

※ Package shown as below for reference.

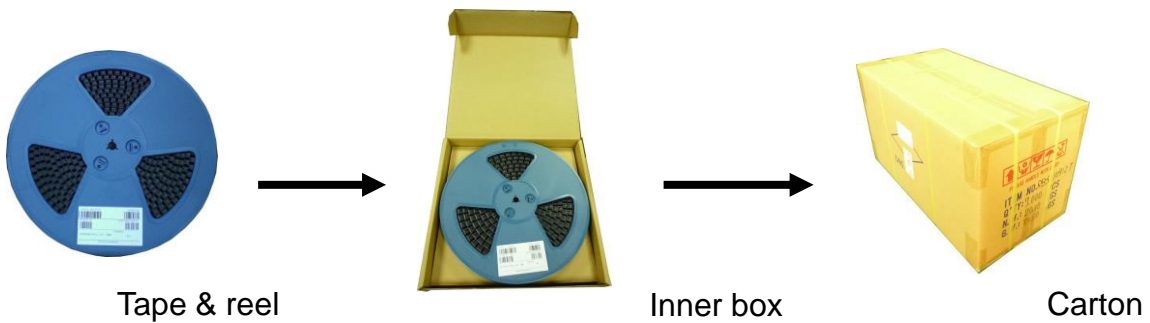

Tilt Sensor Switch

Item No.	RBS152100T	Description	Ball-Contact	Version	12
Page	8 of 8		Publish Date	Jul. 03, 2018	

● NOTE

1. Suggestion for usage: For vibration usage or application, we suggest to add hysteresis for IC; if vibration is heavy, optical type of sensor switch is recommended.
2. For the continued product improvement as one of the company policy, specifications may change or update without notice. The latest information can be obtained through our sales offices. Normally, all products are supplied under our standard conditions.
3. If buyer's products will stay in power supply for a long time which needs very high stability, optical sensor switch is strongly recommended.

● PRECAUTIONS FOR USE

1. If the products is intended to be used for other endurance equipment requiring higher safety and reliability such as life support system, space and aviation devices, disaster and safety system, it's necessary to make verification of conformity or contact us for the details before using.
2. Do not try to clean the switch with a solvent or similar substance after the soldering process.
3. Use water-soluble flux may damage the switch.
4. Please follow the soldering instruction accordingly, otherwise might lead to defective.
5. Do not use switch in the environment of high humidity, because such an environment may cause the leakage current between the terminals.
6. Please do not exceed the rated load as there will be a risk of disabling the product function.
7. In the circuit, switch should not be near or directly connected with the magnetic component solder joints (for example: relays, transformers, etc.).



Mouser Electronics

Authorized Distributor

Click to View Pricing, Inventory, Delivery & Lifecycle Information:

[OncQue:](#)

[RBS152100T](#)