

# IS31LT3954A\_IS32LT3954A DEMO BOARD GUIDE

## DESCRIPTION

The IS31LT3954A/IS32LT3954A is a DC-to-DC switching converter that integrates an N-channel MOSFET to operate in a buck configuration. The device can operate from a wide input voltage between 4.5V and 38V and provides a constant current of up to 3A for driving a single LED or multiple series connected LEDs.

The external resistor,  $R_{ISET}$ , is used to set a constant LED output current, while allowing the output voltage to be automatically adjusted for a variety of LED configurations.

The IS31LT3954A/IS32LT3954A operates in a fixed frequency mode during switching. There is an external resistor connected between the VCC and TON pins used to configure the on-time (switching frequency). The switching frequency is dithered for spread spectrum operation which will spread the electromagnetic energy into a wider frequency band. This function is helpful for optimizing EMI performance.

A logic input PWM signal applied to the enable (EN) pin will adjust the average LED current. The LED brightness is proportional to the duty cycle of the PWM signal.

True average output current operation is achieved with fast transient response by using cycle-by-cycle, controlled on-time method.

In addition, IS31LT3954A/IS32LT3954A integrates various fault protections for robust operation. Detection of these faults is reported by the FAULTB I/O pin. Multiple devices can have their FAULTB pins connected to create a “One-Fail-All-Fail” system operation.

The IS31LT3954A/IS32LT3954A is available in an SOP-8-EP package with an exposed pad for enhanced thermal dissipation. It operates from 4.5V to 38V over the temperature range of -40°C to +125°C.

## QUICK START

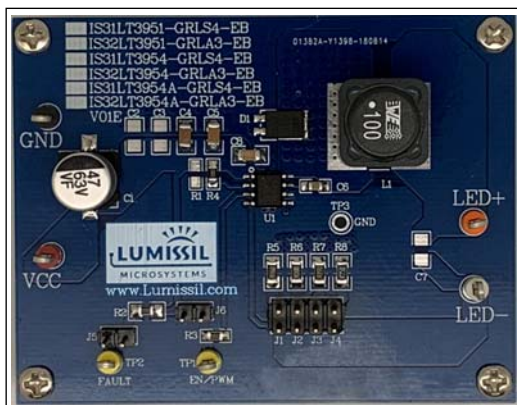

Figure 1: Photo of IS31LT3954A/IS32LT3954A Evaluation Board

## FEATURES

- Wide input voltage supply from 4.5V to 38V
  - Withstand 40V load dump
- True average output current control
- 3A maximum output over operating temperature range
- Cycle-by-cycle current limit
- Integrated high-side MOSFET switch
- Dimming via direct logic input or power supply voltage
- Internal control loop compensation
- Under-voltage lockout (UVLO) and thermal shutdown protection
- 2μA low power shutdown
- Spread spectrum to optimize EMI
- Robust fault protection and reporting function:
  - Pin-to-GND short
  - Component open/short faults
  - Adjacent pin-to-pin short
  - LED open/short
  - Thermal shutdown
- Shared fault flag for multiple device operation to meet “One-Fail-All-Fail”
- AEC-Q100 Qualified
  - IS32LT3954A only

## RECOMMENDED EQUIPMENT

- 38VDC power supply
- 1 pcs of LED panel (3W LEDs, 4LEDs in parallel and then 10 LEDs in series on each panel)
- Multi-meter

## RECOMMENDED INPUT AND OUTPUT RATINGS

- Input: 4.5~38VDC
- Output: 1~10 LEDs in series/3A

## ABSOLUTE MAXIMUM RATINGS

- Input voltage  $\leq$  42VDC

**Caution: Do not exceed the conditions listed above, otherwise the board will be damaged.**

## PROCEDURE

The IS31LT3954A/IS32LT3954A DEMO Board is fully assembled and tested. Follow the steps listed below to verify board operation.

**Caution: Do not turn on the power supply until all connections are completed.**

- 1) Connect the positive terminal of the power supply to the VCC of the board and the negative terminal of the power supply to the GND of the board.

## IS31LT3954A\_IS32LT3954A DEMO BOARD GUIDE

- 2) Connect the negative of the one of the LED panel (LED arrays) to the LED- terminal. And connect the positive of the LED panel (LED arrays) to the LED+ terminal.
- 3) Select  $R_{ISET}$  register on the DEMO Board by JP1~JP4 to set output current, that  $I_{OUT}=0.2/R_{ISET}$ .
- 4) Select EN/PWM pin to VCC by JP6 or connect to a PWM signal generator. Note: when connect to the PWM signal, the JP6 must be open to avoid PWM generator damage.
- 5) Set FAULTB pin to VCC by JP5 or feedback to a MCU. Note: when feedback to the MCU, the JP5 must be open and pulled up on MCU site to avoid MCU damage.
- 6) Turn on the power supply and the LED panels (LED arrays) will be lighted up.

### ORDER INFORMATION

| Part No.             | Temperature Range            | Package             |
|----------------------|------------------------------|---------------------|
| IS31LT3954A-GRLS4-EB | -40°C to +125°C (Industrial) | SOP-8-EP, Lead-free |
| IS32LT3954A-GRLA3-EB | -40°C to +125°C (Automotive) |                     |

For pricing, delivery, and ordering information, please contact Lumissil's analog marketing team at [analog@Lumissil.com](mailto:analog@Lumissil.com) or (408) 969-6600.

### DETAILED DESCRIPTION

#### OUTPUT CURRENT SETTING

The LED current is configured by an external sense resistor,  $R_{ISET}$ , with a value determined as follows Equation (1):

$$I_{LED} = V_{FB} / R_{ISET} \quad (1)$$

Where  $V_{FB} = 0.2V$  (Typ.).

Note that  $R_{ISET} = 0.0667\Omega$  is the minimum allowed value of sense resistor to maintain switch current below the specified maximum value.

**Table 1**  $R_{ISET}$  Resistance Versus Output Current

| $R_{ISET}$ ( $\Omega$ ) | Nominal Average Output Current (mA) |
|-------------------------|-------------------------------------|
| 0.2                     | 1000                                |
| 0.1                     | 2000                                |
| 0.0667                  | 3000                                |

The  $R_{ISET}$  should be a 1% resistor with enough power tolerance and good temperature characteristic to ensure accurate and stable output current.

#### FREQUENCY SELECTION

During switching the IS31LT3954A/IS32LT3954A operates in a consistent on-time mode. The on-time is adjusted by an external resistor,  $R_{TON}$ , which is connected between the VCC and TON pins.

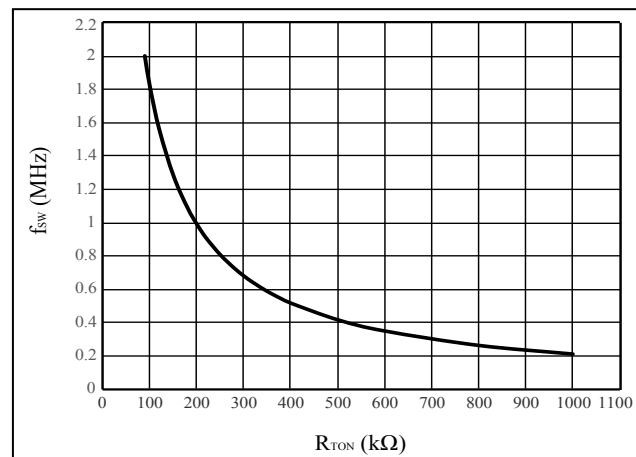

**Figure 2** Operating Frequency vs.  $R_{TON}$  Resistance

The approximate operating frequency can be calculated by below Equation (2) and (3):

$$t_{ON} = \frac{k \times (R_{TON} + R_{INT}) \times V_{OUT}}{V_{CC}} \quad (2)$$

$$f_{sw} = \frac{1}{k \times (R_{TON} + R_{INT})} \quad (3)$$

Where  $k = 0.00458$ , with  $f_{sw}$  in MHz,  $t_{ON}$  in  $\mu s$ , and  $R_{TON}$  and  $R_{INT}$  (internal resistance, 20k $\Omega$ ) in k $\Omega$ .

Higher frequency gets smaller components size but increases the switching losses and high-side MOSFET gate driving current, and may not allow sufficiently high or low duty cycle. Lower frequency gives better performance at larger components size.

#### INDUCTOR

Inductor value involves trade-offs in performance. Larger inductance reduces inductor current ripple that

obtains smaller output current ripple, however it also brings in unwanted parasitic resistance that degrades the performance. Smaller inductance has compact size and lower cost, but introduces higher ripple in the LED string. Use the following equations to estimate the approximate inductor value:

$$L = \frac{(V_{CC} - V_{LED}) \times V_{LED}}{f_{SW} \times \Delta I_L \times V_{CC}} \quad (4)$$

Where  $V_{CC}$  uses the minimum input voltage in volts,  $V_{LED}$  is the total forward voltage of LED string in volts,  $f_{SW}$  is the operation frequency in hertz.  $\Delta I_L$  is the current ripple in the inductor. Select an inductor with a rating current over output average current and the saturation current over the Over Current Protection (OCP) current threshold  $I_{SWLIM}$ .

Since IS31LT3954A/IS32LT3954A is a Continuous Conduction Mode (CCM) buck driver which means the valley of the inductor current,  $I_{MIN}$ , should not drop to zero all the time, the  $\Delta I_L$  must be smaller than 200% of the average output current.

$$I_{MIN} = I_{LED} - \frac{\Delta I_L}{2} > 0 \quad (5)$$

Besides, the peak current of the inductor,  $I_{MAX}$ , must be smaller than  $I_{SWLIM}$  to prevent device from triggering OCP, especially the output current is set to high level.

$$I_{MAX} = I_{LED} + \frac{\Delta I_L}{2} < I_{SWLIM} \quad (6)$$

On the other hand, the  $\Delta I_L$  has to be higher than 10% of the average output current all the time to ensure the system stability. For the better performance, recommend to choose the inductor current ripple  $\Delta I_L$  between 10% and 50% of the average output current.

$$0.1 \times I_{LED} \leq \Delta I_L \leq 0.5 \times I_{LED} \quad (7)$$

Below figure shows the inductance selection based on operating frequency and LED current at 30% inductor current ripple. If the lower operating frequency is adopted, either the larger inductance or current ripple should be used.

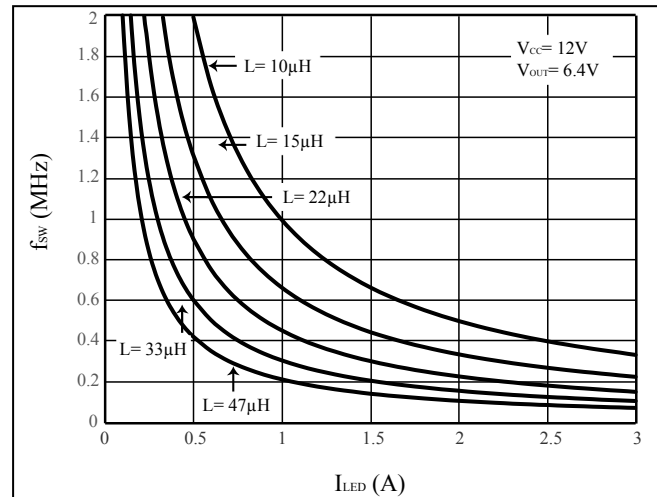

**Figure 3** Inductance Selection Based On 30% Current Ripple

## FAULT HANDLING

The IS31LT3954A/IS32LT3954A is designed to detect the following faults and report via open drain FAULTB pin:

- Pin open
- Pin-to-ground short (except LX pin)
- Pin-to-neighboring pin short
- Output LED string open and short
- External component open or short (except diode)
- Thermal shutdown

Please check Table 2 for the details of the fault actions.

## FAULTB PARALLEL INTERCONNECTION

FAULTB is a fault reporting output pin and as well as an input pin. Externally pulling FAULTB pin low will disable the output. For lighting systems with multiple IS31LT3954A/IS32LT3954A drivers which require the complete lighting system be shut down when a fault is detected, the FAULTB pin can be used in a parallel connection. A fault output by one device will pull low the FAULTB pins of the other parallel connected devices and simultaneously turn them off. This satisfies the “One-Fail-All-Fail” operating requirement. Note that the FAULTB pin is an open drain structure. An external pull up resistor to FAULTB pin is needed. The recommended value is 47kΩ.

## PCB LAYOUT CONSIDERATION

As for all switching power supplies, especially those providing high current and using high switching frequencies, layout is an important design step. If layout is not carefully done, the operation could show instability as well as EMI problems.

The high dV/dt surface and dI/dt loops are big noise emission source. To optimize the EMI performance, keep the area size of all high switching frequency points with high voltage compact. Meantime, keep all

## IS31LT3954A\_IS32LT3954A DEMO BOARD GUIDE

---

traces carrying high current as short as possible to minimize the loops.

- (1) Wide traces should be used for connection of the high current paths that helps to achieve better efficiency and EMI performance. Such as the traces of power supply, inductor  $L_1$ , current recirculating diode  $D_1$ , LED load and ground.
- (2) Keep the traces of the switching points shorter. The inductor  $L_1$ , LX and current recirculating diode  $D_1$  should be placed as close to each other as possible and the traces of connection between them should be as short and wide as possible.
- (3) To avoid the ground jitter, the components of parameter setting,  $R_{ISET}$ , should be placed close to the device and keep the traces length to the device pins as short as possible. On the other side, to prevent the noise coupling, the traces of  $R_{ISET}$  should either be far away or be isolated from high-current paths and high-speed switching nodes. These practices are essential for better accuracy and stability.
- (4) The capacitor  $C_{IN}$  should be placed as close as possible to VCC pin for good filtering.
- (5) Place the bootstrap capacitor  $C_{BOOT}$  close to BOOT pin and LX pin to ensure the traces as short as possible.
- (6) The connection to the LED string should be kept short to minimize radiated emission. In practice, if the LED string is far away from the driver board, an output capacitor is recommended to be used and placed on driver board to reduce the current ripple in the connecting wire.
- (7) The thermal pad on the back of device package must be soldered to a sufficient size of copper ground plane with sufficient vias to conduct the heat to opposite side PCB for adequate cooling

# IS31LT3954A\_IS32LT3954A DEMO BOARD GUIDE

**Table 2 Fault Actions**

| Fault Type                        | LED String | Detect Condition   |   | FAULTB Pin                                     |   | Fault Recovering   |
|-----------------------------------|------------|--|---|--|---|--|
| Inductor shorted                  | Dim        | Trigger OCP. Turn off high-side MOSFET immediately. Retry after 1ms.   |   | Pull Low after second OCP cycle.               |   | Inductor shorted removed. No OCP triggered and FAULTB pin recover after 10ms.                                      |
| R <sub>ISET</sub> short           | Dim        | Trigger OCP. Turn off high-side MOSFET immediately. Retry after 1ms.   |   | Pull Low after second OCP cycle.               |   | R <sub>ISET</sub> shorted removed. No OCP triggered and FAULTB pin recover after 10ms.                             |
| R <sub>ISET</sub> open            | Off        | The FB pin voltage exceeds 2V. Turn off high-side MOSFET immediately. Retry after 1ms.   |   | Pull Low immediately.                          |   | R <sub>ISET</sub> open removed. The FB pin voltage drops below 1.55V and FAULTB pin recover after 10ms.            |
| LED string open                   | Off        | No PWM dimming:  | FB pin average voltage drops below 0.2V for 10ms.   | No PWM dimming:                                | Pull Low after 10ms.  | LED open removed. FB average voltage keep at 0.2V for 10ms and FAULTB pin recover.                                 |
|                                   |            | PWM dimming:   | FB pin average voltage drops below 0.2V after 25 $\mu$ s deglitch time and keeps for 128 PWM cycles.                                  | PWM dimming:                                   | Pull low after 128 PWM cycles or the on-time over 20 $\mu$ s. |  |
| LED string shorted                | Off        | No PWM dimming:  | Filter V <sub>LX</sub> to get V <sub>OUT</sub> , if V <sub>OUT</sub> <1V for 10ms   | No PWM dimming:                                | Pull Low after 10ms.  | Shorted removed. V <sub>OUT</sub> >1V for 10ms and FAULTB pin recover.   |
|                                   |            | PWM dimming:   | Filter V <sub>LX</sub> to get V <sub>OUT</sub> , if V <sub>OUT</sub> <1V after 25 $\mu$ s deglitch time and keeps for 128 PWM cycles. | PWM dimming:                                   | Pull low after 128 PWM cycles.                                |  |
| LED string shorted to GND         | Off        | Trigger OCP. Turn off high-side MOSFET immediately. Retry after 1ms.   |   | Pull Low after second OCP cycle.               |   | Shorted removed. No OCP triggered and FAULTB pin recover after 10ms.   |
| BOOT capacitor open               | Dim        | V <sub>CC</sub> -V <sub>SW</sub> >1.8V at high-side MOSFET ON (High-side can't fully turn on). Turn off high-side MOSFET immediately. Retry after 1ms. |   | Pull Low immediately                           |   | BOOT capacitor open removed, V <sub>CC</sub> -V <sub>SW</sub> <1.8V for 10ms and FAULTB pin recover.               |
| BOOT capacitor shorted            | Off        | Bootstrap circuit UVLO and turn off high-side MOSFET immediately.  |   | No PWM dimming:                                | Pull Low after 10ms.  | BOOT capacitor shorted removed. Release from UVLO and FAULTB pin recover after 10ms                                |
|                                   |            |  |   | PWM dimming:                                   | Pull low after 128 PWM cycles.                                |  |
| R <sub>TON</sub> resistor open    | Dim        | On-time exceeds 20 $\mu$ s or trigger OCP, then turn off high-side MOSFET immediately. Retry after 1ms.  |   | Pull Low after 20 $\mu$ s or second OCP cycle. |   | R <sub>TON</sub> resistor open removed. No over 20 $\mu$ s on-time or OCP triggered. FAULTB pin recover after 10ms |
| R <sub>TON</sub> resistor shorted | Dim        | The device operating at minimum on/off time, maybe trigger the other fault conditions.   |   | No reporting                                   |   | R <sub>TON</sub> resistor shorted removed.   |
| EN short to R <sub>ISET</sub>     | Off        | EN/PWM will be pulled low by R <sub>ISET</sub> resistor.   |   | No reporting                                   |   | EN short to R <sub>ISET</sub> removed.   |
| Thermal Shutdown                  | Off        | The die temperature exceeds 165°C  |   | Pull low immediately                           |   | The die temperature cools down below 140°C. FAULTB pin recovers immediately.                                       |

# IS31LT3954A\_IS32LT3954A DEMO BOARD GUIDE

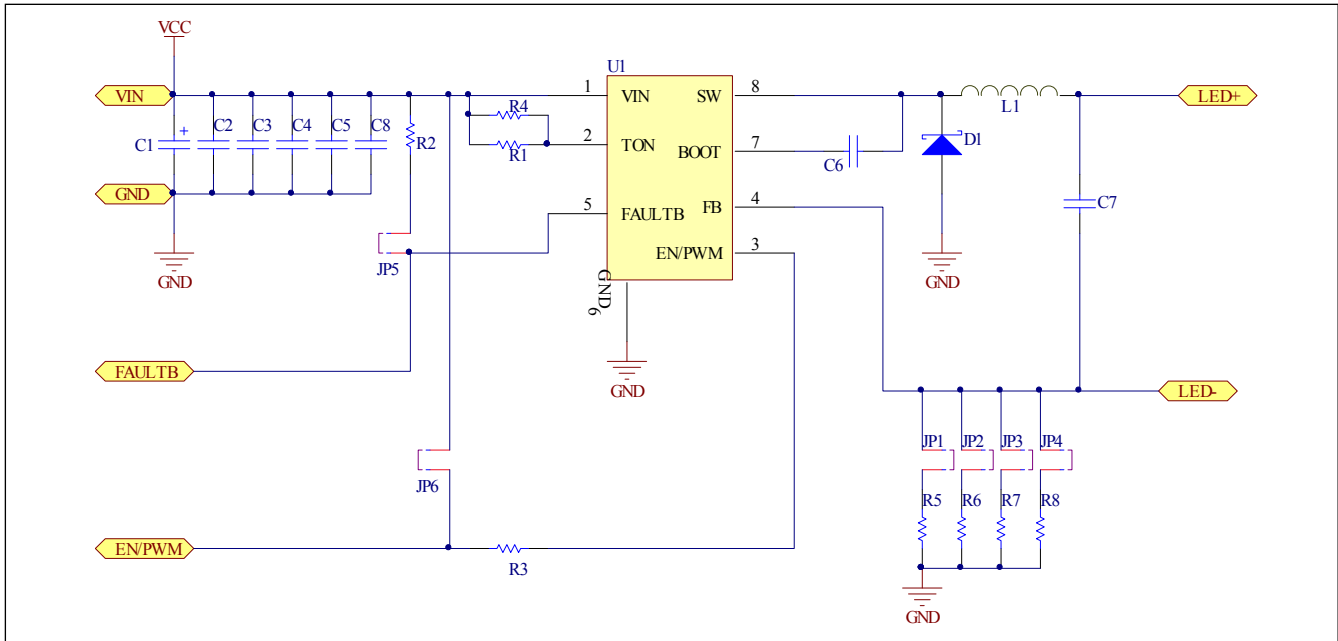

Figure 4: IS31LT3954A/IS32LT3954A Demo Board Schematic

## BILL OF MATERIALS

| Name      | Symbol   | Description                          | Qty | Supplier         | Part No.                                     |
|-----------|----------|--------------------------------------|-----|------------------|--|
| IC        | U1       | Constant current LED driver          | 1   | Lumissil         | IS31LT3954A-GRLS4-TR<br>IS32LT3954A-GRLA3-TR |
| E-Cap     | C1       | CAP,47 $\mu$ F,63V, $\pm$ 20%        | 1   | Panasonic        | EEV-TG1J470P                                 |
| Capacitor | C2,C3,C7 | NC                                   |     |                  |  |
| Capacitor | C4,C5,C8 | CAP,10 $\mu$ F,50V, $\pm$ 10%,SMD    | 3   | Yageo            | AC1206KKX7R9BB106                            |
| Capacitor | C6       | CAP,100nF,50V, $\pm$ 10%,SMD         | 1   | Yageo            | AC0805KKX7R9BB104                            |
| Resistor  | R1       | RES,430k,1/8W, $\pm$ 5%,SMD          | 1   | Yageo            | AC0805JR-07430KL                             |
| Resistor  | R2       | RES,10k,1/8W, $\pm$ 5%,SMD           | 1   | Yageo            | AC0805JR-0710KL                              |
| Resistor  | R3       | RES,1k,1/8W, $\pm$ 5%,SMD            | 1   | Yageo            | AC0805JR-0701KL                              |
| Resistor  | R5~R8    | RES,0.27R,1/4W, $\pm$ 1%,SMD         | 4   | Yageo            | RL1206FR-070R27L                             |
| Resistor  | R4       | NC                                   |     |                  |  |
| Diode     | D1       | 5A,100V, Power DI 5                  | 1   | Diodes           | PDS5100                                      |
| Inductor  | L1       | 10uH $\pm$ 20%,Isat $\geq$ 10.5A,SMD | 1   | Würth Elektronik | 7447709100                                   |

Note: Bill of materials refers to Figure 4 above.

# IS31LT3954A\_IS32LT3954A DEMO BOARD GUIDE

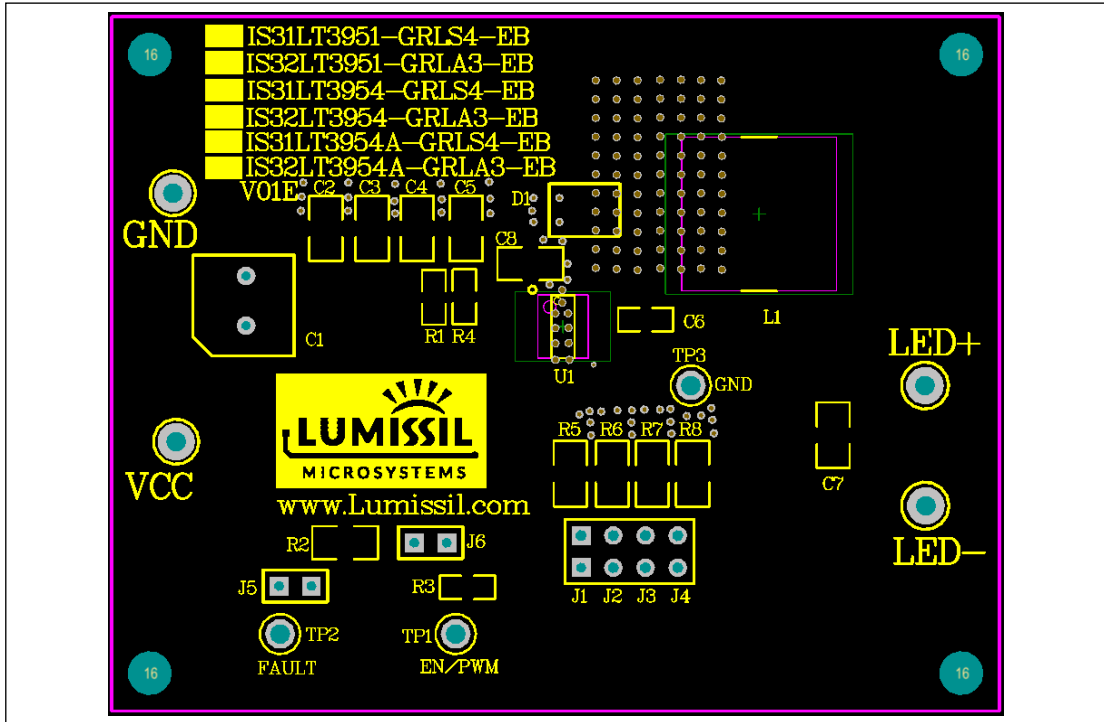

Figure 5: Board Component Placement Guide - Top Layer

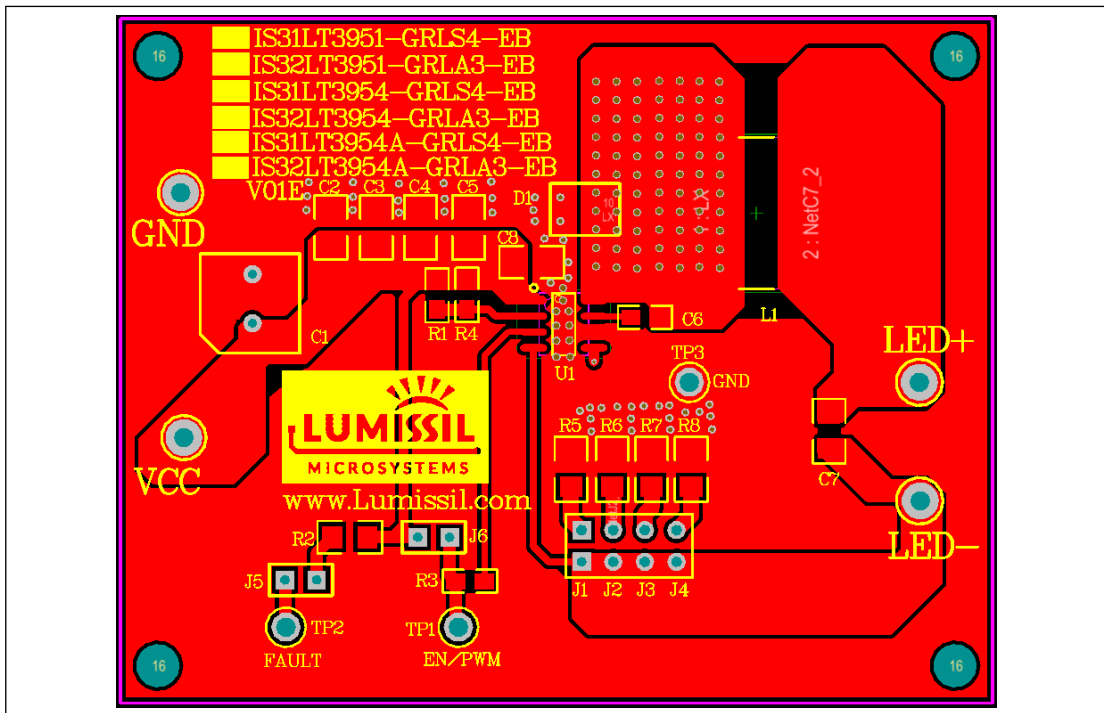
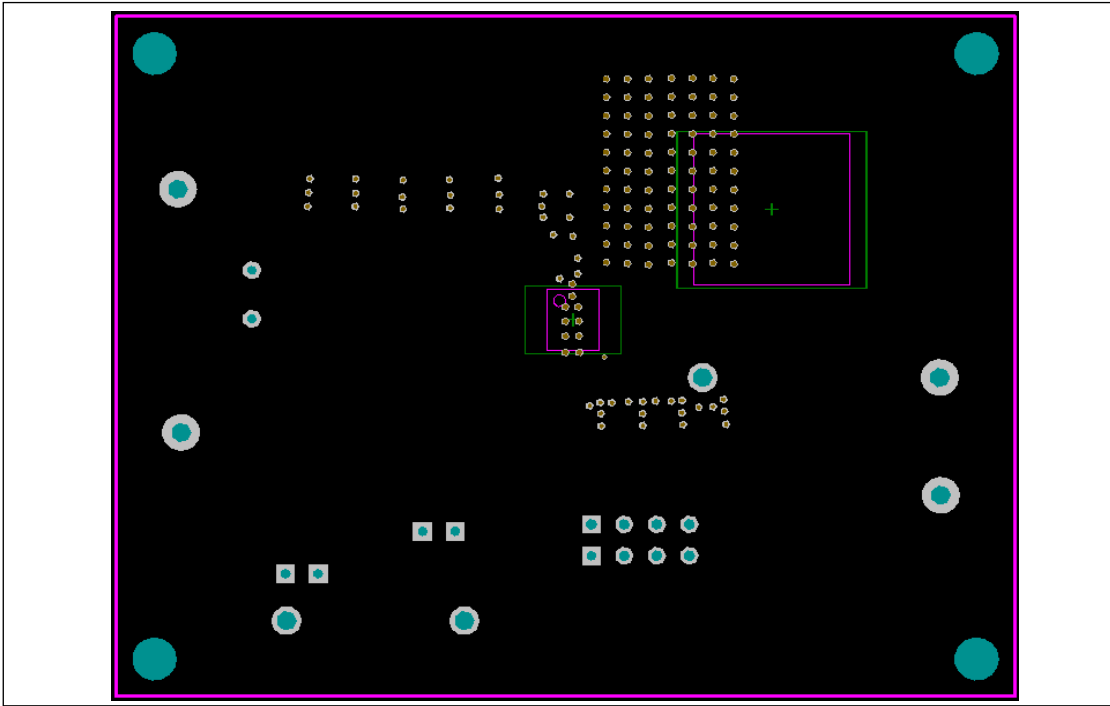
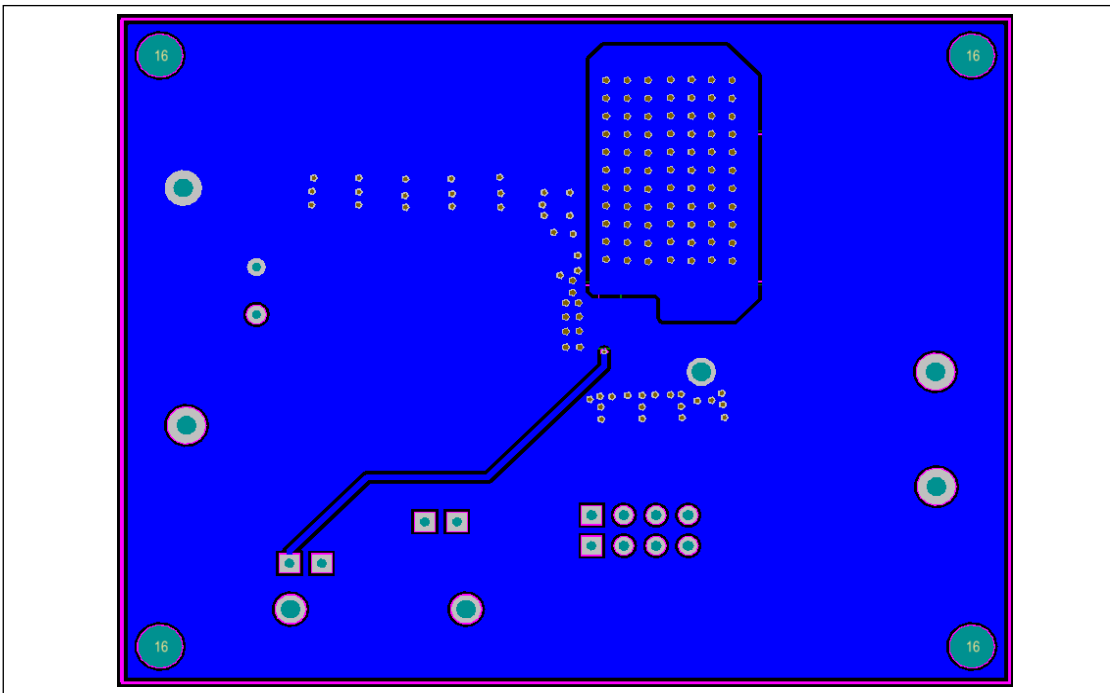

Figure 6: Board PCB Layout - Top Layer





**Figure 7: Board Component Placement Guide - Bottom Layer**



**Figure 8: Board PCB Layout - Bottom Layer**

Copyright © 2020 Lumissil Microsystems. All rights reserved. Lumissil Microsystems reserves the right to make changes to this specification and its products at any time without notice. Lumissil Microsystems assumes no liability arising out of the application or use of any information, products or services described herein. Customers are advised to obtain the latest version of this device specification before relying on any published information and before placing orders for products.

Lumissil Microsystems does not recommend the use of any of its products in life support applications where the failure or malfunction of the product can reasonably be expected to cause failure of the life support system or to significantly affect its safety or effectiveness. Products are not authorized for use in such applications unless Lumissil Microsystems receives written assurance to its satisfaction, that:

- a.) the risk of injury or damage has been minimized;
- b.) the user assume all such risks; and
- c.) potential liability of Lumissil Microsystems is adequately protected under the circumstances



## REVISION HISTORY

| Revision | Detail Information  | Date       |
|----------|---------------------|------------|
| A        | Initial release     | 2018.11.12 |
| B        | Add IS32LT3954A P/N | 2020.04.08 |
| C        | Update BOM list     | 2020.09.15 |

# Mouser Electronics

Authorized Distributor

Click to View Pricing, Inventory, Delivery & Lifecycle Information:

[Lumissil:](#)

[IS31LT3954A-GRLS4-EB](#)