

Jan.1.2022 Copyright 2022 HIROSE ELECTRIC CO., LTD. All Rights Reserved.
In case of consideration for using Automotive equipment / device which demand high reliability, kindly contact our sales window correspondents.

Fig.2(1:1)

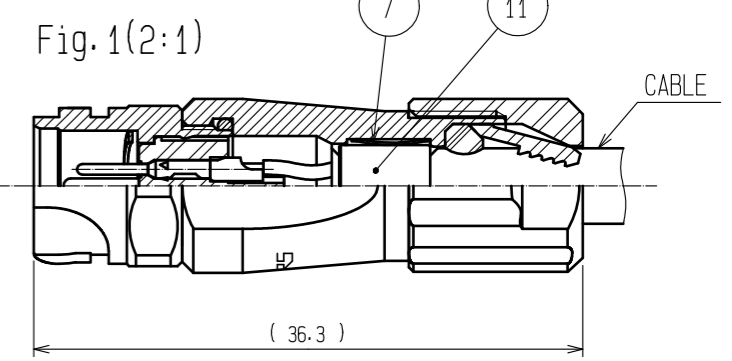
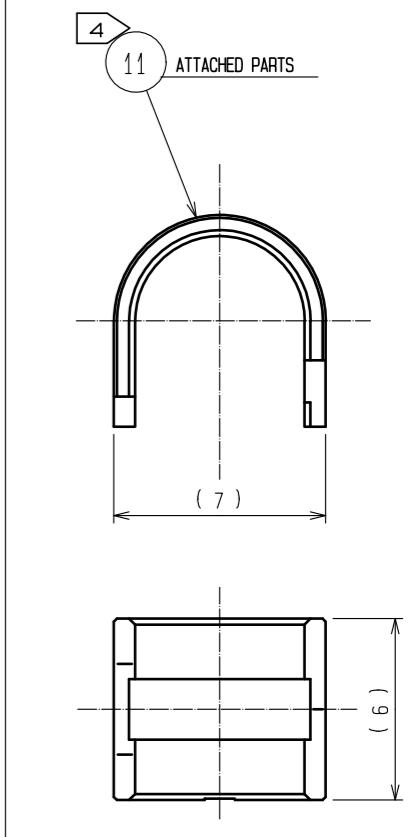
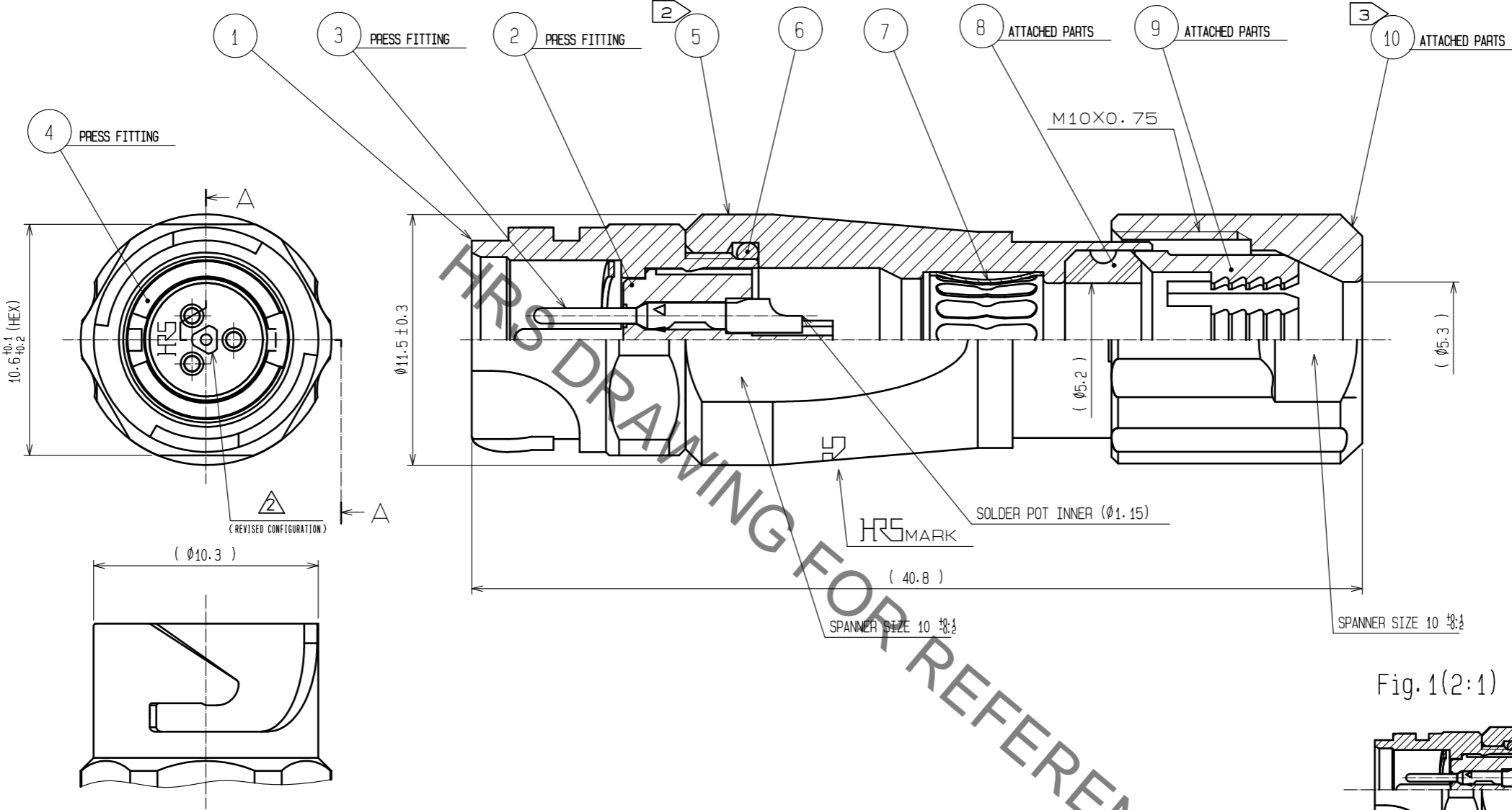
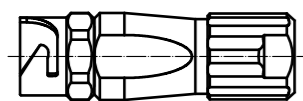

- NOTES
- ① PLATING(REF.NO. ③)
CONTACT AREA : GOLD 0.2μm min
OTHERS : GOLD AND NICKEL
UNDER PLATING : NICKEL 2μm min
 - ② THE RECOMMENDED CLAMP TORQUE OF REF.NO. ⑤ TO BE 1 TO 1.5N·m.
THREAD LOCKER TO THE THREADED PORTION OF REF.NO. ① IS RECOMMENDED TO PREVENT REF.NO. ⑤ FROM LOOSING.
 - ③ RECOMMENDED THREAD LOCKER: LOCTITE 263, HENKEL JAPAN LTD.
 - ④ THE RECOMMENDED CLAMP TORQUE OF REF.NO. ⑩ TO BE 0.8 TO 1N·m.
THREAD LOCKER AND LOCK PRIMER TO THE THREADED PORTION M10X0.75 OF REF.NO. ⑤ IS RECOMMENDED TO PREVENT REF.NO. ⑩ FROM LOOSING.
 - ⑤ RECOMMENDED THREAD LOCKER AND LOCK PRIMER : LOCTITE 263, LOCK PRIMER 7649, HENKEL JAPAN LTD.
 - ⑥ FASTEN REF.NO. ⑪ TO THE CABLE WITH THE CABLE CRIMPING TOOL.
AND MAKE REF.NO. ⑪ CONTACT WITH REF.NO. ⑦ (REFER TO Fig.1).
REFER TO THE TECHNICAL SPECIFICATION ATAD-C0099 FOR DETAILS.
APPLICABLE CABLE CRIMPING TOOL : HR10A-TC-02(CL150-0041-2)(THE HOLE DIAMETER FOR CRIMPING:Ø5.3)
 - ⑦ Fig.2 SHOWS THE APPEARANCE AFTER ASSEMBLY.
 - ⑧ ROTATION EXAMPLES OF REF. NOS ⑤ AND ⑩ TO ① ARE SHOWN.
 - ⑨ APPLICABLE CABLE ASSEMBLY FIXTURE : LF07BJ-T01(CL150-0233-3)
CABLE ASSEMBLY FIXTURE IS USED AS A RECEPTACLE STAND OF EXTRACT
AND THE PART No. ① OF AN ASSEMBLY.

NO.	MATERIAL	FINISH . REMARKS	NO.	MATERIAL	FINISH . REMARKS
6	CHLOROPRENE RUBBER	(BLACK)			
5	ZINC ALLOY	NICKEL PLATING	11	BRASS	NICKEL PLATING
4	PHOSPHOR BRONZE	NICKEL PLATING	10	PPS	(NATURAL·BROWN) UL94V-0
3	COPPER ALLOY	①	9	POLYAMIDE	(NATURAL·MILKY WHITE) UL94V-0
2	PPS	(BLACK) UL94V-0	8	CHLOROPRENE RUBBER	(BLACK)
1	ZINC ALLOY	NICKEL PLATING	7	PHOSPHOR BRONZE	NICKEL PLATING

UNITS	SCALE	COUNT	DESCRIPTION OF REVISIONS	DESIGNED	CHECKED	DATE
mm	4 : 1	3	DIS-C-00001700	HY. KISHI	HY. KOBAYASHI	17. 08. 11

APPROVED	MR. YOSHIDA	05. 01. 05	DRAWING NO.	EDC3-114150-00
CHECKED	MO. SATOH	05. 01. 05	PART NO.	LF07WBJ-3P
DESIGNED	YH. YAMADA	05. 01. 05	CODE NO.	CL136-2003-8-00
DRAWN	YH. YAMADA	05. 01. 05		

Mouser Electronics

Authorized Distributor

Click to View Pricing, Inventory, Delivery & Lifecycle Information:

[Hirose Electric:](#)

[LF07WBJ-3P](#)