

Aug.1.2021 Copyright 2021 HIROSE ELECTRIC CO., LTD. All Rights Reserved.
In case of consideration for using Automotive equipment / device which demand high reliability, kindly contact our sales window correspondents.

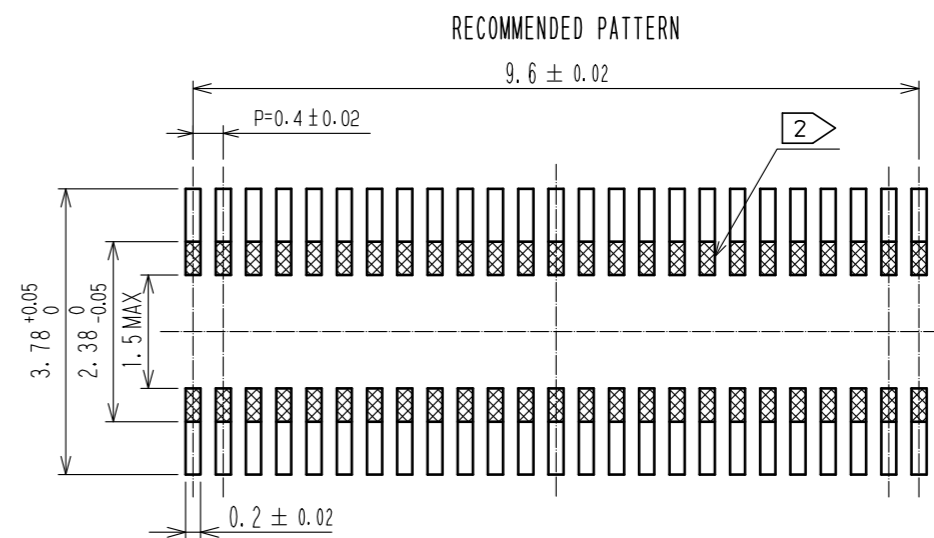

RECOMMENDED METAL MASK THICKNESS: 120 μm
RECOMMENDED MASK OPENING RATIO: 80% FOR LEAD PAD

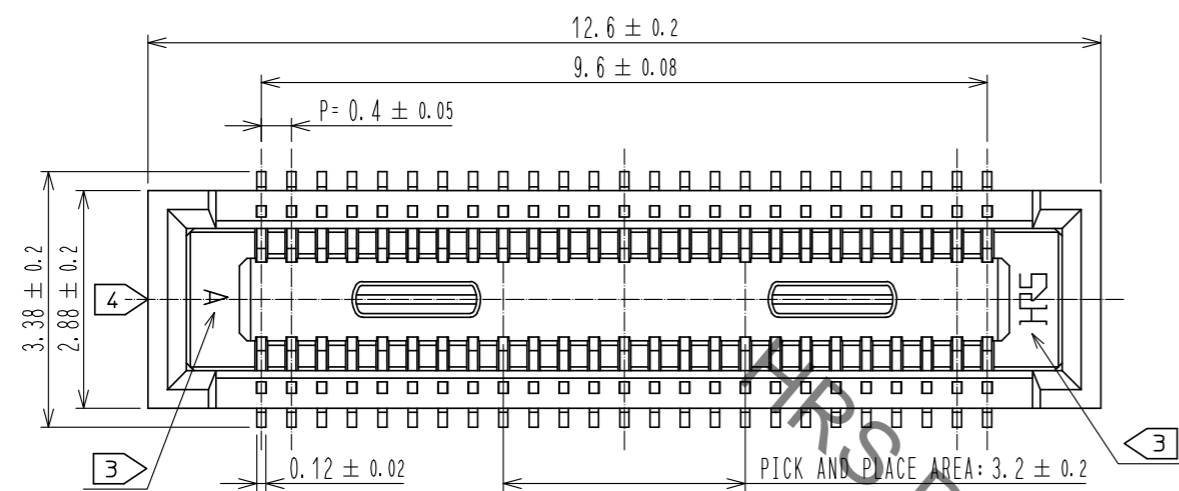
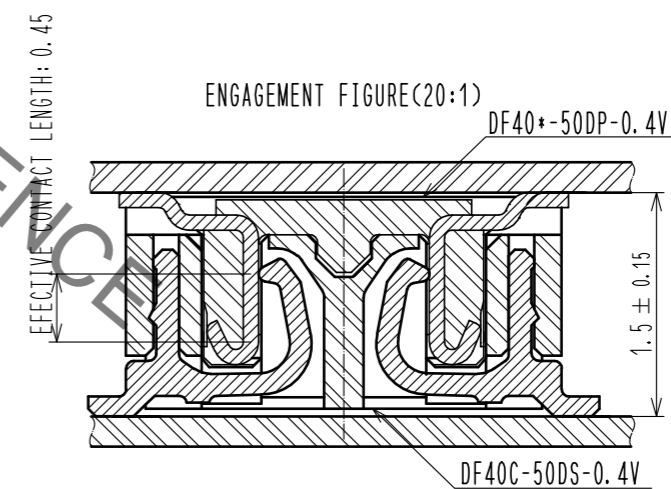
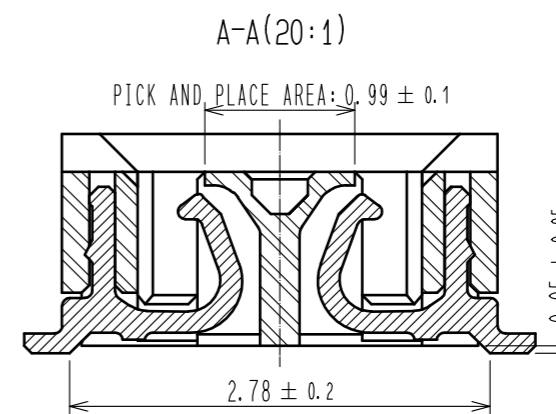
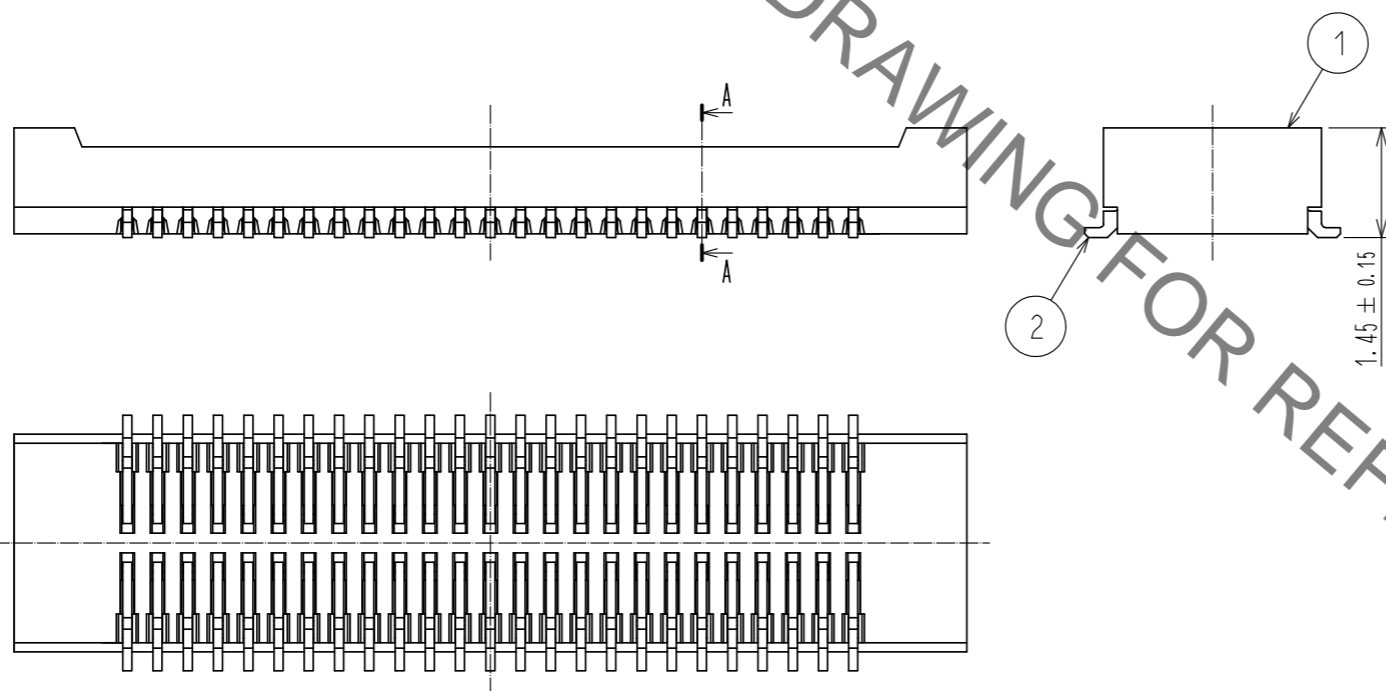

- NOTES) 1. ALL LEADS METAL FITTINGS CO-PLANARITY SHALL BE 0.1mm MAX.
 2. IS NO PATTERN AREA OTHER THAN THE SAME CIRCUIT.
 3. HRS MARK AND CAV NO. IS INDICATED IN APPROXIMAL POSITION SHOWN.
 4. GATE POSITION IS POSITIONED IN APPROXIMAL AREA SHOWN.

2	PHOSPHOR BRONZE	CONTACT AREA: GOLD 0.05 μm MIN	6	PS	CLEAR, REINFORCEMENT COLLAR			
		SMT LEAD: GOLD 0.05 μm MIN	5	PS	BLACK			
		UNDERPLATING: NICKEL 1 μm MIN	4	POLYESTER	CLEAR, COVER TAPE			
1	LCP	BLACK, UL94V-0	3	PS	CLEAR, EMBOSSED CARRIER TAPE			
NO.	MATERIAL	FINISH . REMARKS	NO.	MATERIAL	FINISH . REMARKS			
UNITS mm		SCALE 10 : 1	COUNT 	DESCRIPTION OF REVISIONS		DESIGNED	CHECKED	DATE
HRS HIROSE ELECTRIC CO., LTD.		APPROVED : MO. ISHIDA	16. 10. 05	DRAWING NO.		EDC-311341-58-01		
		CHECED : TS. MIYAZAKI	16. 10. 05	PART NO.		DF40C-50DS-0.4V (58)		
		DESIGNED : SH. HOSODA	16. 10. 05	CODE NO.		CL684-4009-0-58		
		DRAWN : SN. NUMAZAKI	16. 10. 04			1/2		

Aug.1.2021 Copyright 2021 HIROSE ELECTRIC CO., LTD. All Rights Reserved.
In case of consideration for using Automotive equipment / device which demand high reliability, kindly contact our sales window correspondents.

EMBOSSED CARRIER TAPE PACKAGING(5:1)

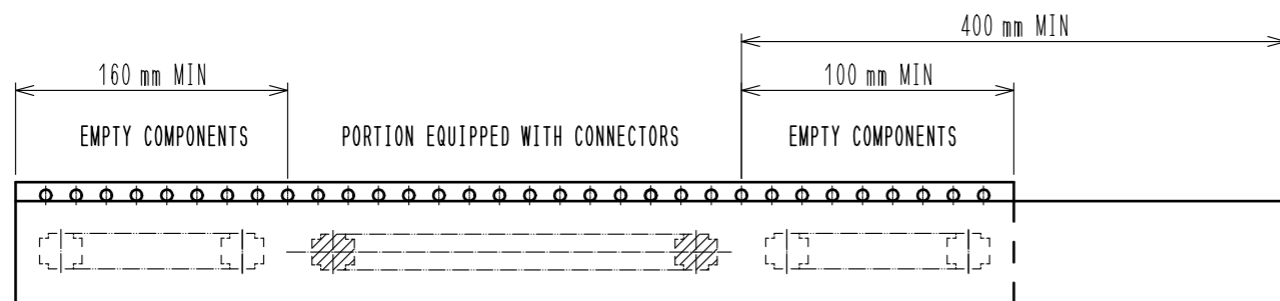
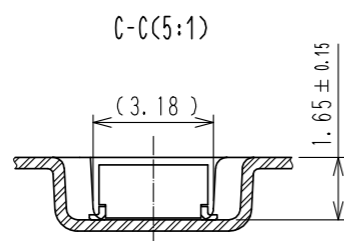
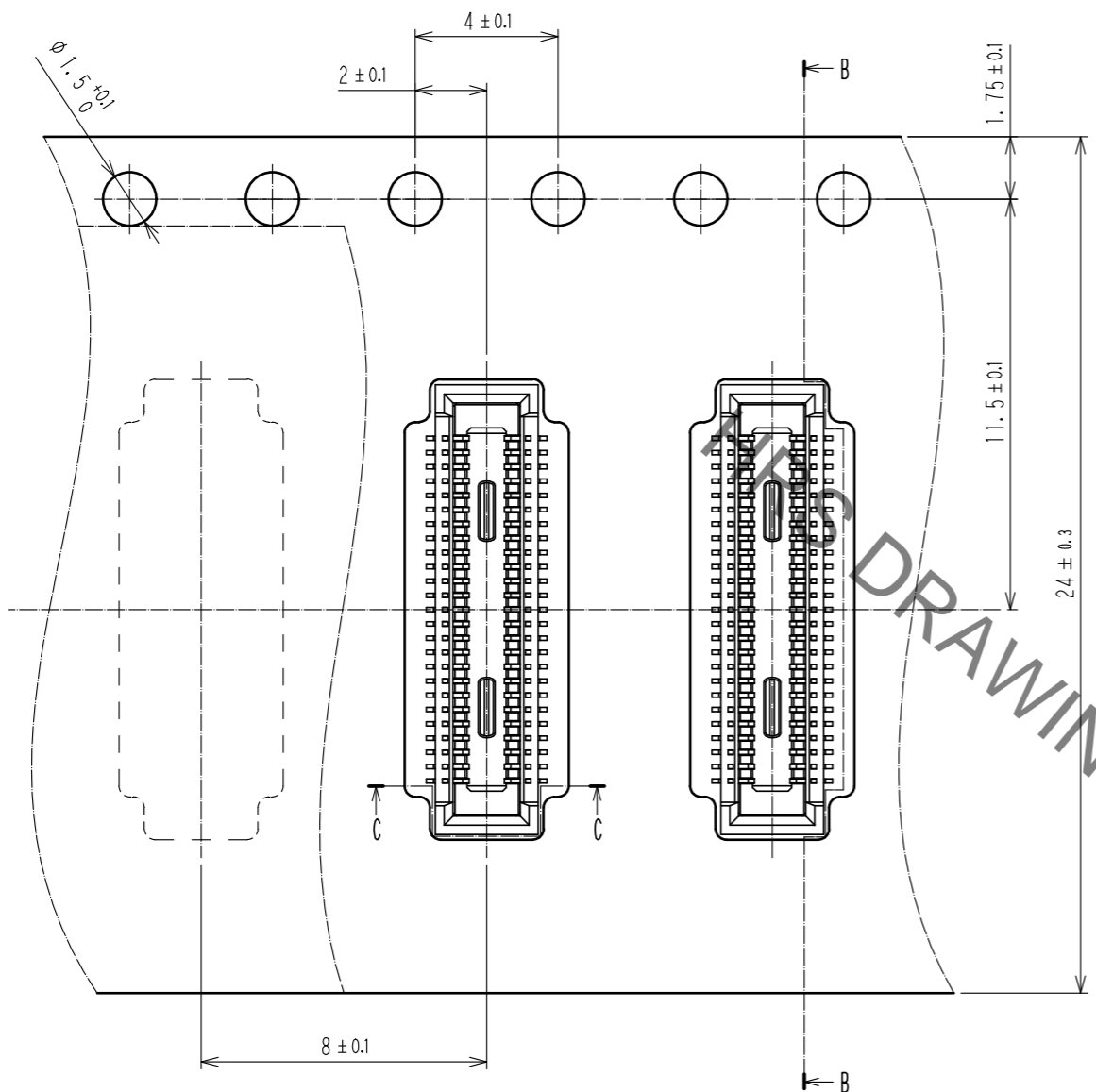

STYLE AND DIMENSION OF REEL(FREE)

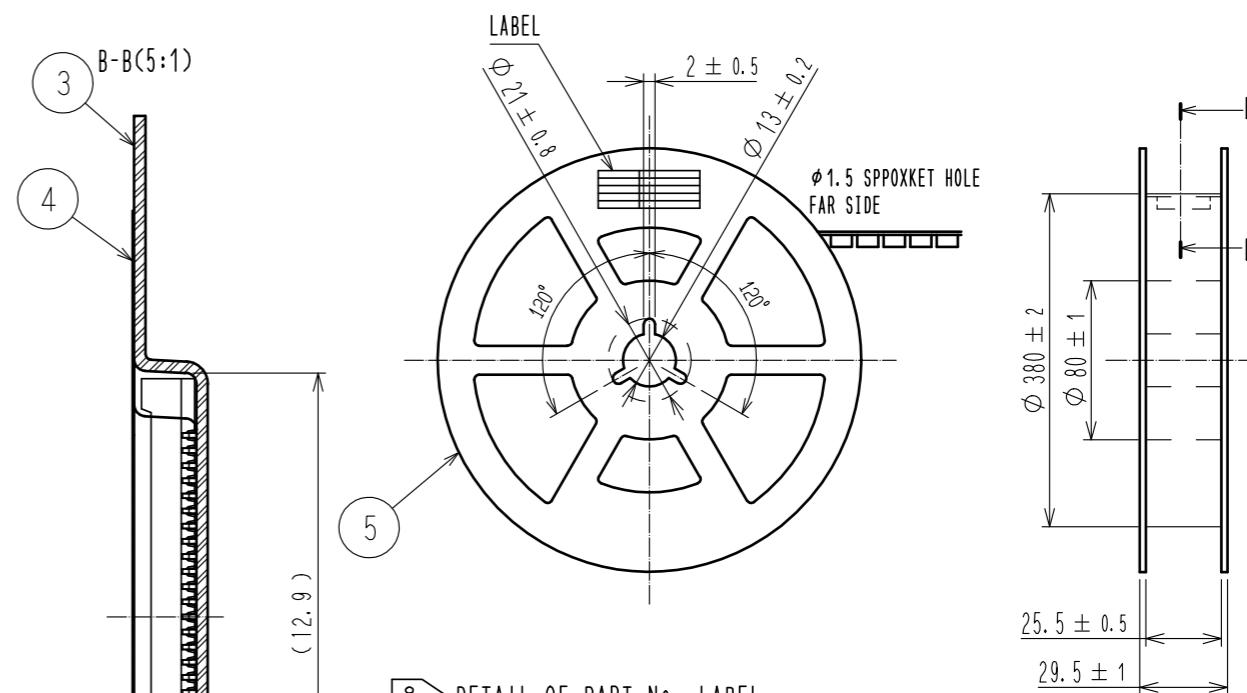

8 > DETAIL OF PART No. LABEL

製造年月日	** ** *
製品コード	CL684-4009-0-58
製品名	DF40C-50DS-0.4V(58)
数量	1000
納入者	ヒロセ電機(株)

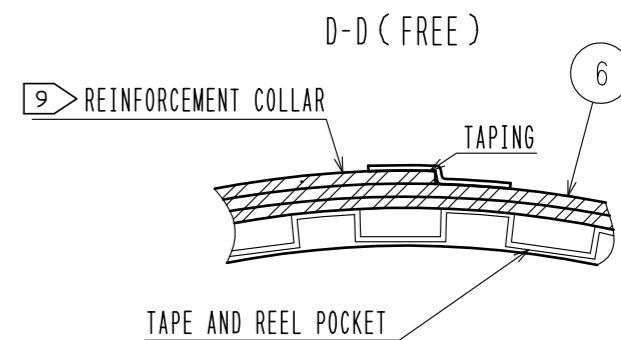

- NOTES
- PER REEL 1000 CONNECTORS.
 - THE DIMENSIONS IN PARENTHESES ARE FOR REFERENCE.
 - REFER TO JIS C 0806(PACKING OF COMPONENTS FOR AUTOMATIC HANDLING)
 - DETAIL OF PART No. LABEL IS WRITTEN IN JAPANESE.
PART No. LABEL DESCRIBES THE FOLLOWING INFORMATION FROM TOP.
PRODUCTION DATE:
PRODUCT CODE: CL684-4009-0-58
PART NUMBER: DF40C-50DS-0.4V(58)
NUMBER OF PIECES: 1000 PIECES
SUPPLIER NAME: HIROSE ELECTRIC CO., LTD.
 - AFTER PACKAGING, ROLL 2 METERS OF THE REINFORCEMENT COLLAR TO OUTER CIRCUMFERENCE OF TAPE AND REEL POCKET, AND TAPE DOWN AT THE END THE COLLAR.

HRS	DRAWING NO.	EDC-311341-58-01
	PART NO.	DF40C-50DS-0.4V(58)
	CODE NO.	CL684-4009-0-58
		2/2

Mouser Electronics

Authorized Distributor

Click to View Pricing, Inventory, Delivery & Lifecycle Information:

[Hirose Electric:](#)

[DF40C-50DS-0.4V\(58\)](#)