

Tous droits strictement réservés. Reproduction ou communication à des fins interdites sans autorisation écrite du propriétaire. Propriété de FCI. Droits de reproduction FCI.

A FCI

All rights strictly reserved. Reproduction or issues in third parties in any form whatever is not permitted without written authority from the proprietor. Property of FCI. Copyright FCI.

REFERENCE SPECIFICATIONS

- DIN 41652 PART 2
- DRAFT IEC 352-5
- IEC-512 (TESTS PROCEDURE)

PHYSICAL CHARACTERISTICS

- INSULATOR MATERIAL:
- PBT COLOR BLACK-RAL 7001/STANDARD MATERIAL
- CONTACT MATERIAL: - PHOSPHOR BRONZE
- GROUNDING DEVICE MATERIAL: - BRASS
- ACCESSORIES: BRASS

ELECTRICAL CHARACTERISTICS

- MAXIMUM RATING CURRENT: 5A AT 20°C / 2.5A AT 70°C
- NOMINAL CURRENT: 5A (STANDARD CONDITIONS)
- CONTACT RESISTANCE: straight terminations: <10mΩ
- Right angled termination: <25mΩ for 9 to 37 way
- <35mΩ for 50 way
- VOLTAGE PROOF: >1000 V.r.m.s.
- RATED VOLTAGE: 300 V.r.m.s.
- insulation resistance: >5000mΩ
- creepage and clearance distance: >1mm
- average wiping length: 2mm

MECHANICAL CHARACTERISTICS

- RETENTION AGAINST TORQUE: - Threaded insert: 0.7 N.m minimum
- Female screw lock: 0.5 N.m minimum
- INSERTION AND WITH DRAWAL FORCE: <n x 3.40 N (n number of cts)
- GAUGE RETENTION FORCE: >0.20 N (gauge PM)
- THICKNESS GAUGE = $\varnothing 0.99 \pm 0.005$ / SURFACE ROUGHNESS:
- Ra=0.10µ mini- 0.25µ maxi
- CONTACT RETENTION IN INSULATOR: mini 16N for straight contact
- mini 20N for right angled contact
- VIBRATIONS: 10-2000Hz / 1.5 mm - 20g / 3 x 2 HRS
- INTERRUPTION <1µs (NOT APPLICABLE FOR PL3)
- SHOCK: ACC. HALF SINE 50g- 11m.s-6x3 SHOCKS
- INTERRUPTION <1µs

PERFORMANCE LEVELS

MECHANICAL ENDURANCE ONLY			MECHANICAL ENDURANCE AND INDUSTRIAL ATMOSPHERE TEST(1)		
P/N: DXXXXCXXXXXX	PERFORMANCE LEVELS		P/N: DXXXXCXXXXXX	PERFORMANCE LEVELS	
4	200 OPERATIONS	PL3	4	salt spray: 24 hours	PL3
6	400 OPERATIONS	PL1	6	250 op + test (1 or 2)-10 days + 250 op	PL1

1) INDUSTRIAL ATMOSPHERE TEST: 3 GASES available for contacts and grounding device
 IN ACCORDANCE WITH IEC-68-2-60-TTD - TEST ke - MTH C OR IEC 512-6 TEST IIg
 MIXED GASES: H2S=10 PPB±5.10-9vol/vol +N2O=200±50.10-9 vol/vol + CL2=10±5.10-9vol/vol
 TEMPERATURE = 30±1°C / RELATIVE HUMIDITY= 70±3°C
 (2) INDUSTRIAL ATMOSPHERE TEST: 4 GASES available for contacts active area only
 BELCORE TEST: MIXED GASES: H2S=10 PPB±5 vol/vol +N2O=200ppb±50 vol/vol + CL2 =10ppb±3vol/vol + S2O=100ppb±30vol/vol
 TEMPERATURE = 30±1°C / RELATIVE HUMIDITY= 70±2°C

ENVIRONMENTAL CHARACTERISTICS

- CLIMATIC CATEGORY: 55/125/56
 TEMPERATURE RANGE -55°C TO +125°C
 DAMP HEAT STEADY STATE 56 DAYS

METALLIZED HOLE DIMENSION

P.C.B. HOLE DEFINITION (NOTE -1 AND -2)	HOLE PRESS-FIT CONTACT SnPb $\varnothing A$	HOLE PRESS-FIT CONTACT Sn $\varnothing B$	HOLE PRESS-FIT HARPOONS SnPb $\varnothing B$	HOLE PRESS-FIT HARPOONS Sn $\varnothing A$
DRILL DIAMETER	$\varnothing 1.15$ REF (NOTE -3)	$\varnothing 1.15$ REF (NOTE -3)	$\varnothing 3.22$ REF (note-3)	$\varnothing 3.22$ REF (note-3)
DRILLED HOLE	$\varnothing 1.12 - 1.18$	$\varnothing 1.12 - 1.18$	$\varnothing 3.19 - 3.25$	$\varnothing 3.19 - 3.25$
COPPER PLATING	25µ MINI (recommended 50µ maxi)	25µ MINI (recommended 50µ maxi)	25µ MINI (recommended 50µ maxi)	25µ MINI (recommended 50µ maxi)
TIN LEAD PLATING	15µ MAXI (recommended 5µ mini)		25µ MINI (recommended 50µ maxi)	
FINISH HOLE(AFTER REFLOW)	$\varnothing 0.94 - 1.09$	$\varnothing 1.00 - 1.09$	$\varnothing 3.02 - 3.20$	$\varnothing 3.08 - 3.20$
TIN PLATING		0.8 to 1.2µ		0.8 to 1.2µ

NOTE1: THESE DIMENSIONS MUST BE RESPECT TO SECURE PRESS-FIT PIN PERFORMANCES.
 NOTE-2: ACCORDING TO IEC -352-5 SPEC.
 NOTE-3: MAJOR REQUIREMENT FOR PRESS-FIT PIN PERFORMANCE

PLATING FOR TIN LEAD VERSIONS

- CONTACT:
- GOLD OVER NICKEL ON MATING SURFACES
- TIN LEAD OVER NICKEL ON TERMINATION PARTS
- SHELL AND ACCESSORIES TIN LEAD OVER COPPER

PLATING FOR TIN VERSIONS, TERMINATIONS LF ONLY

NOTE RoHS INFORMATIONS
 - The "LF" products meet European union Directives and other country regulations as described in GS-22-008
 - Active Part: Gold over Nickel
 - Termination plating spec: 0.5 to 3 µm Nickel, 0.5 to 1.5 µm Sn
 - Shell plating: 2 to 4 µm Cu + 3 to 10 µm Sn (pure bright)
 - Accessories: Sn pure bright
 - Packaging spec: see GS-14-920

PRESS-FIT PERFORMANCE

	PRESS-FIT CONTACTS	PRESS-FIT HARPOONS
INSERTION FORCE	< 100N	< 120N
SnPb/Sn EXTRACTION FORCE	> 30N	> 30N
Copper EXTRACTION FORCE	> 20N	> 20N

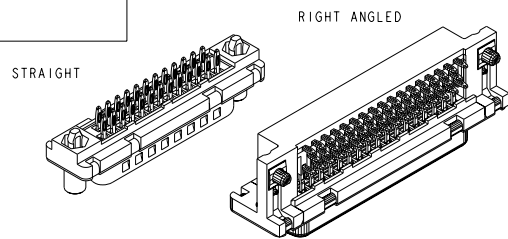
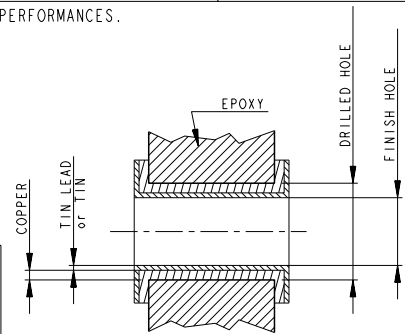

A FCI	www.fciconnect.com		surface - <input checked="" type="checkbox"/>	tolerance ISO 406	projection	mm
			ISO 1302	ISO 1101		
Dr	JOUBERT	01/10/96	Product family		size A3	Scale 1:1
Eng	PESSON	01/10/96	Spec ref			
Chr	LEGARE	01/10/96	Material		SEE NOTES	ECN LS05-0056
Appr	LEGARE	01/10/96				
DELTA D PRESSFIT CONNECTORS			dwg no		C01-8646-0001	
GENERAL CHARACTERISTICS			- CUSTOMER COPY		Rev. E	
catalog no					sheet 1 of 1	

Mouser Electronics

Authorized Distributor

Click to View Pricing, Inventory, Delivery & Lifecycle Information:

[FCI / Amphenol:](#)

[D09S91C6PX00LF](#) [D09P80C6GV00LF](#) [D09P80C6GX00LF](#) [D09P81C6GL00LF](#) [D09P81C6GV00LF](#)
[D09P82C4GV00LF](#) [D09P82C4GX00LF](#) [D09P90C6GV00LF](#) [D09P90C6PX00LF](#) [D09P91C4GV00LF](#)
[D09P91C4PL00LF](#) [D09P91C4PV00LF](#) [D09P91C4PX00LF](#) [D09P91C6GV00LF](#) [D09P91C6GX00LF](#)
[D09P91C6PL00LF](#) [D09P91C6PV00LF](#) [D09P91C6PX00LF](#) [D09S80C6GV00LF](#) [D09S80C6PA00LF](#)
[D09S81C4GL00LF](#) [D09S81C4GX00LF](#) [D09S81C6GL00LF](#) [D09S81C6GV00LF](#) [D09S81C6GX00LF](#)
[D09S82C6GL00LF](#) [D09S90C6GV00LF](#) [D09S90C6GX00LF](#) [D09S90C6PV00LF](#) [D09S90C6PX00LF](#)
[D09S91C4GV00LF](#) [D09S91C4GX00LF](#) [D09S91C4PL00LF](#) [D09S91C6GL00LF](#) [D09S91C6GV00LF](#)
[D09S91C6GX00LF](#) [D09S91C6PL00LF](#) [D15P81C6GL00LF](#) [D15P81C6GX00LF](#) [D15P82C4PA00LF](#)
[D15P82C6GL00LF](#) [D15P90C6PA00LF](#) [D15P90C6PV00LF](#) [D15P90C6PX00LF](#) [D15P91C4PA00LF](#)
[D15P91C4PV00LF](#) [D15P91C4PX00LF](#) [D15P91C6GV00LF](#) [D15P91C6PA00LF](#) [D15P91C6PV00LF](#)
[D15P91C6PX00LF](#) [D15S81C4GX00LF](#) [D15S82C4GL00LF](#) [D15S82C6GV00LF](#) [D15S90C6GV00LF](#)
[D15S90C6GX00LF](#) [D15S90C6PA00LF](#) [D15S90C6PV00LF](#) [D15S91C4GV00LF](#) [D15S91C4PL00LF](#)
[D15S91C4PV00LF](#) [D15S91C4PX00LF](#) [D15S91C6GV00LF](#) [D15S91C6PA00LF](#) [D15S91C6PL00LF](#)
[D15S91C6PV00LF](#) [D15S91C6PX00LF](#) [D25P81C4GV00LF](#) [D25P81C6GL00LF](#) [D25P82C4GV00LF](#)
[D25P82C6GV00LF](#) [D25P82C6GX00LF](#) [D25P82C6PA00LF](#) [D25P90C4PV00LF](#) [D25P90C6GL00LF](#)
[D25P90C6PA00LF](#) [D25P91C4PV00LF](#) [D25P91C4PX00LF](#) [D25P91C6GX00LF](#) [D25P91C6PA00LF](#)
[D25P91C6PL00LF](#) [D25P91C6PX00LF](#) [D25S80C4GL00LF](#) [D25S80C6GX00LF](#) [D25S81C4GX00LF](#)
[D25S81C6GL00LF](#) [D25S81C6GV00LF](#) [D25S82C4GL00LF](#) [D25S82C6GL00LF](#) [D25S82C6GV00LF](#)
[D25S82C6GX00LF](#) [D25S82C6PA00LF](#) [D25S90C4PV00LF](#) [D25S90C6PV00LF](#) [D25S90C6PX00LF](#)
[D25S91C4GL00LF](#) [D25S91C4GV00LF](#) [D25S91C4GX00LF](#) [D25S91C4PA00LF](#) [D25S91C4PL00LF](#)