

REVISIONS

ISS	ZONE	DESCRIPTION\PER REQUEST\DATE
D	B-8	NO.6 WAS CHANGED\RD-DM91091701L\11-12-02'
D1	B-6	CANCELLED L AND M KEY CODING\N/A\02-13-03'
E	C-4	ADD 4 ROUND RIBS ON CLIP, FKLC00001B WAS FKLC00001A \RD-DM06032401B\ 24-Mar-06
E1	B-4	ADDED: ±0.20, REMOVED 8mm\ECO\8-05-06'
F	B-6	ADDED L M N KEY CODING \RD-DM93081001L\ 27-Sep-07

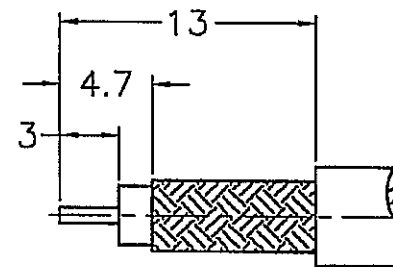

RECOMMENDED CABLE STRIPPING DIM'S (建議剝線尺寸)

1. CRIMPED FERRULE HEX. CRIMP SIZE .213"
2. CRIMPED CONTACT PIN SQ. CRIMP SIZE .042"

CONFIGURATION CONTROL:
NO CHANGES PERMITTED TO DRAWING WITHOUT PPAP QUALIFIED CUSTOMER APPROVAL

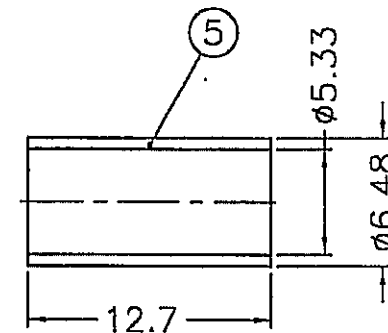
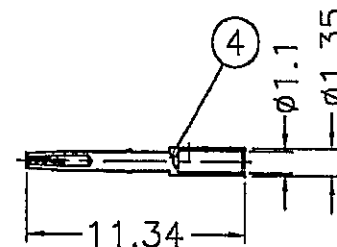
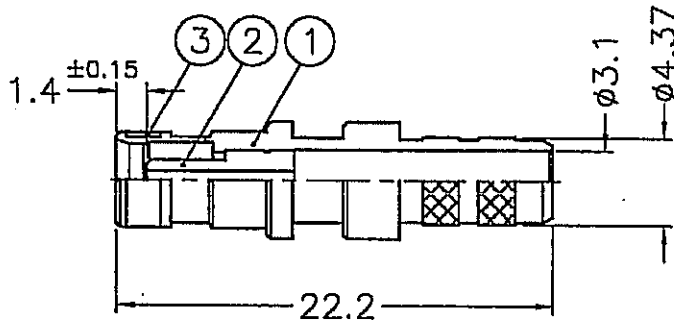
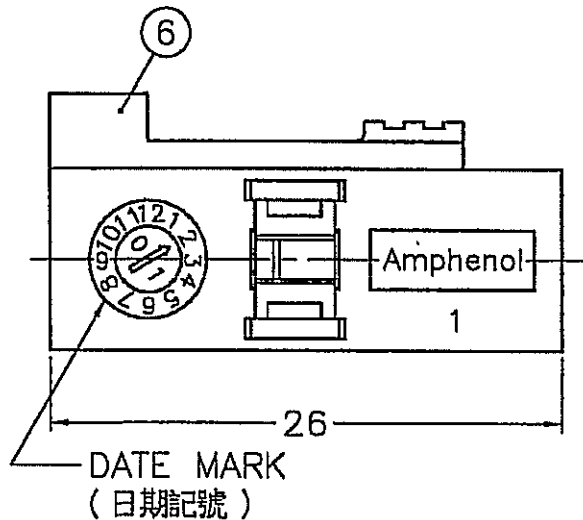

TABLE

KEY CODING	PART NO.	DRAWING NO.	ITEM NO.	LOCK COVER
A	FA1-NASJ-C04-0	FK6121AW-008-NT30G-50	FK6121AA57NC5F	FKLC30101D
B	FA1-NBSJ-C04-0	FK6121BW-008-NT30G-50	FK6121AB57NC5F	FKLC30102D
C	FA1-NCSJ-C04-0	FK6121CW-008-NT30G-50	FK6121AC57NC5F	FKLC30103D
D	FA1-NDSJ-C04-0	FK6121DW-008-NT30G-50	FK6121AD57NC5F	FKLC30104D
E	FA1-NESJ-C04-0	FK6121EW-008-NT30G-50	FK6121AE57NC5F	FKLC30105D
F	FA1-NFSJ-C04-0	FK6121FW-008-NT30G-50	FK6121AF57NC5F	FKLC30106D
G	FA1-NGSJ-C04-0	FK6121GW-008-NT30G-50	FK6121AG57NC5F	FKLC30107D
H	FA1-NHSJ-C04-0	FK6121HW-008-NT30G-50	FK6121AH57NC5F	FKLC30108D
I	FA1-NISJ-C04-0	FK6121IW-008-NT30G-50	FK6121AI57NC5F	FKLC30109D
K	FA1-NKSJ-C04-0	FK6121KW-008-NT30G-50	FK6121AK57NC5F	FKLC30110D
Z	FA1-NZSJ-C04-0	FK6121ZW-008-NT30G-50	FK6121AZ57NC5F	FKLC30111D
L	FA1-NLSJ-C04-0	FK6121LW-008-NT30G-50	FK6121AL57NC5F	FKLC30112D
M	FA1-NMSJ-C04-0	FK6121MW-008-NT30G-50	FK6121AM57NC5F	FKLC30113D
N	FA1-NNSJ-C04-0	FK6121NW-008-NT30G-50	FK6121AN57NC5F	FKLC30114D

NOTES: FINISH (PLATING THICKNESS IN MICRO-INCHES)

1. BRASS PER QQ-B-626, ALLOY 360, 1/2 H ; JIS H3250 C 3604BD OR EQUIVALENT
2. NICKEL PL. 60 MIN. THICK OVER COPPER STRIKE
3. BERYLLIUM COPPER PER QQ-C-530, ALLOY 173, 1/2 H ; FUJII FX301 OR EQUIVALENT
4. GOLD PL. 30 MIN. THICK OVER NICKEL PL. 100 MIN. THICK OVER COPPER STRIKE
5. TEFLON MIL-P-19468 OR EQUIVALENT
6. BERYLLIUM COPPER JIS C1720R-1/4H OR EQUIVALENT
7. COPPER PER ASTM B-75 ALLOY C12200 OR EQUIVALENT
8. NYLON66(WITH 33% GLASS FIBER) PER NYTEX COMPOSITES CO., LTD. GRADE MG-0033N-V0 OR EQUIVALENT
9. PBT(WITH 15% GLASS FIBER) PER CHANG CHUN GRADE 4115202

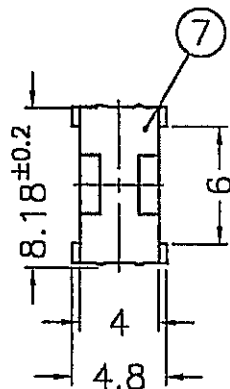

DIMENSIONS ARE IN MILLIMETERS

UNLESS OTHERWISE SPECIFIED TOLERANCES

- 0.5-6 = ±0.2
- 6-30 = ±0.4
- 30-120 = ±0.6
- 120-315 = ±1
- 315-1000 = ±1.6
- 1000-2000 = ±2.4

PART NO.	FA1-NXSJ-C04-0
APPROVED	Angela W DATE 28-Sep-07
CHECKED	Angela W DATE 28-Sep-07
DRAWN	Evan DATE 27-Sep-07
FILE NO.	F:\DWG\FK\6121XX\008\50\NT30G-FSZ

Amphenol	
Danbury,CT,USA-Tainan,Taiwan-Shenzhen,China	
TITLE	FAKRA SMB CRIMP JACK (FOR RG-58A/U, 58C/U CABLE)
DRAWING NO.	FK6121XX-008-NT30G-50
ITEM NO.	FK6121AAX57NC5F

NO.	DESCRIPTION	MATERIAL	FINISH	Q'TY	DRAWING NO.
7	LOCK COVER	NATURAL	1	FKLC00001B	
6	LOCK COVER	NATURAL	1	SEE TABLE	
5	FERRULE	NATURAL	1	FKFR00201A	
4	CONTACT PIN	NATURAL	1	FKCP00401A	
3	RETAINER RING	NATURAL	1	FKRR00101A	
2	INSULATOR	NATURAL	1	FKNS00501A	
1	BODY	NATURAL	1	FKBD00501A	

Mouser Electronics

Authorized Distributor

Click to View Pricing, Inventory, Delivery & Lifecycle Information:

[Amphenol:](#)

[FA1-NDSJ-C04-0](#)