

REV. A	SHEET 1 OF 2	ZPEKL-( )-( )
REVISIONS		
LTR	DESCRIPTION	DATE
A	INITIAL RELEASE	9-15-06

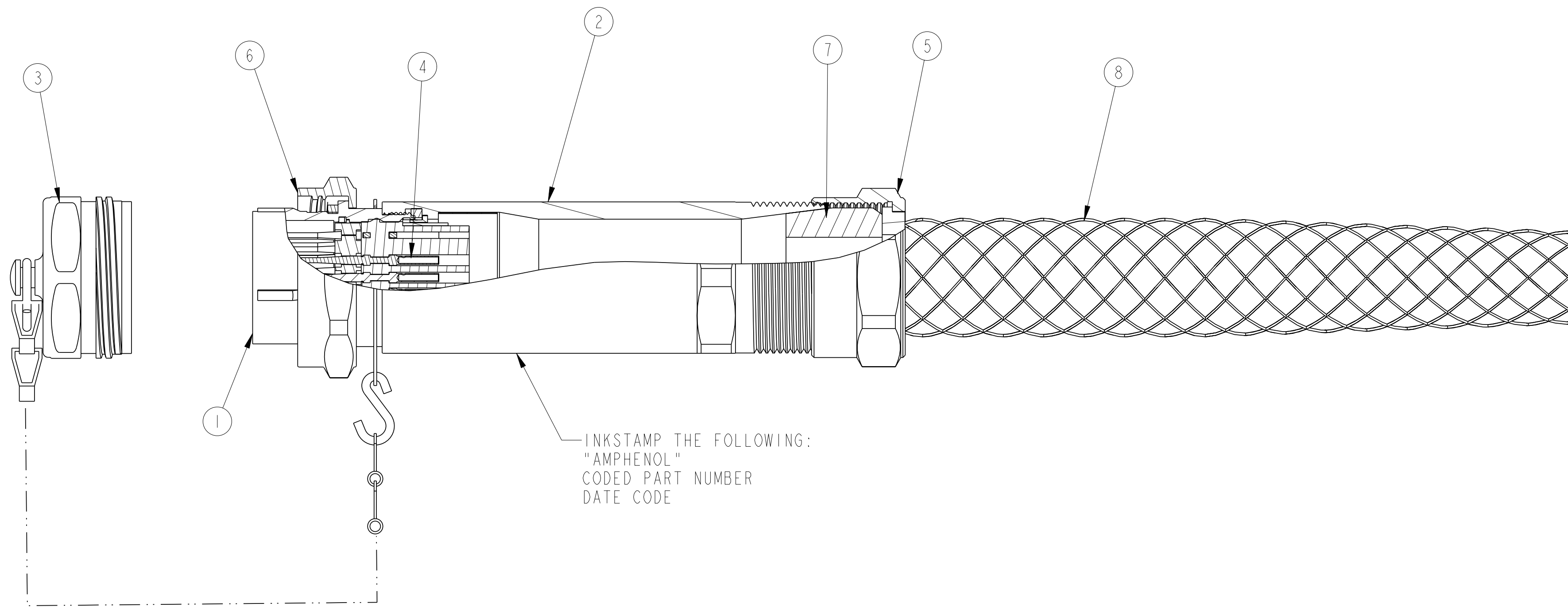

INKSTAMP THE FOLLOWING:  
 "AMPHENOL"  
 CODED PART NUMBER  
 DATE CODE

SECTION A-A  
 SCALE 1.000

POS	QTY	PART NUMBER	DESCRIPTION	NOTE
8	1	ZP-50( )-( )E	BASKETWEAVE CABLE GRIP	
7	1	ZP-63( )-( )C	GROMMET	
6	1	ZP-70( )-10A	COUPLING NUT	
5	1	ZP-73( )-10A	HEX NUT	
4	1	ZP-( )-( )	INSERT ASSEMBLY	
3	1	ZP-W-55( )-A	COVER ASSEMBLY	
2	1	ZP-W-24( )	CABLE ADAPTER ASSEMBLY	
1	1	ZP-W-13( )-200	SHELL ASSEMBLY	

PARTS LIST

4. IDENTIFY PACKAGE WITH AMPHENOL ASSEMBLY NUMBER.
3. UNITS MEET THE APPLICABLE REQUIREMENTS FOR MIL-C-5015.
2. SEE SEPERATE PARTS LIST FOR COMPONENT PARTS AND QUANTITIES.
1. PACKAGE PER PRODUCTION PROCESS SHEET. ALL PARTS SHOWN ASSEMBLED FOR REFERENCE.

NOTES:

THE USE OF THIS DOCUMENT IS UNLIMITED. HOWEVER, DOCUMENTS REFERENCED HEREON MAY CONTAIN LIMITED RIGHTS DATA.

UNLESS OTHERWISE SPECIFIED  
 SPECIFICATIONS  
 LINEAR DIMENSIONS ARE IN INCHES  
 TOLERANCES:  
 .XXXX = ±.0005 ANGLES= ±2°  
 .XXX = ±.010  
 .XX = ±.03  
 .X = ±.1  
 DIM. & TOL. PER ASME Y14.5M;  
 DRM PER MIL-DTL-31000;  
 OTHER Amphenol Stds. PER 9-3800  
 LEGENDS:  
 =FLAG NOTE CALL OUT REFERENCE ONLY

APPROVALS	DATE
PREPARED BY P. BRUNING	14-Sep-06
ENGINEER IN CHARGE P. BRUNING	
DESIGN MANAGER D. GALLUSSER	
DESIGN ACTIVITY GROUP C&I	
THIRD ANGLE PROJECTION	

**AMPHENOL CORPORATION**  
 40-60 DELAWARE AVENUE  
 SIDNEY, N.Y. 13838

**STARLINE PLUG ASSEMBLY  
 W/ COVER, BASKETWEAVE GRIP AND  
 LONG CABLE ADAPTER**

SIZE	CAGE CODE	DOCUMENT NO.	REV.
C	77820	ZPEKL-( )-( )	A

SCALE: 0.3 REF: ZPEKL-1416-321PN SHEET 1 OF 2

N/A	PRO/ENGINEER INFORMATION
N/A	Pro/e Model Used: ZPEKL.ASSEM
N/A	Drawing Name: ZPEKL-xx-xxx
N/A	NEXT ASSEMBLY

ZPEKL-( )-( ) DOCUMENT NO. SHEET 1 OF 2 REV. A

ZPEKL-( )-( ) DOCUMENT NO. SHEET 1 OF 2 REV. A

4

3

2

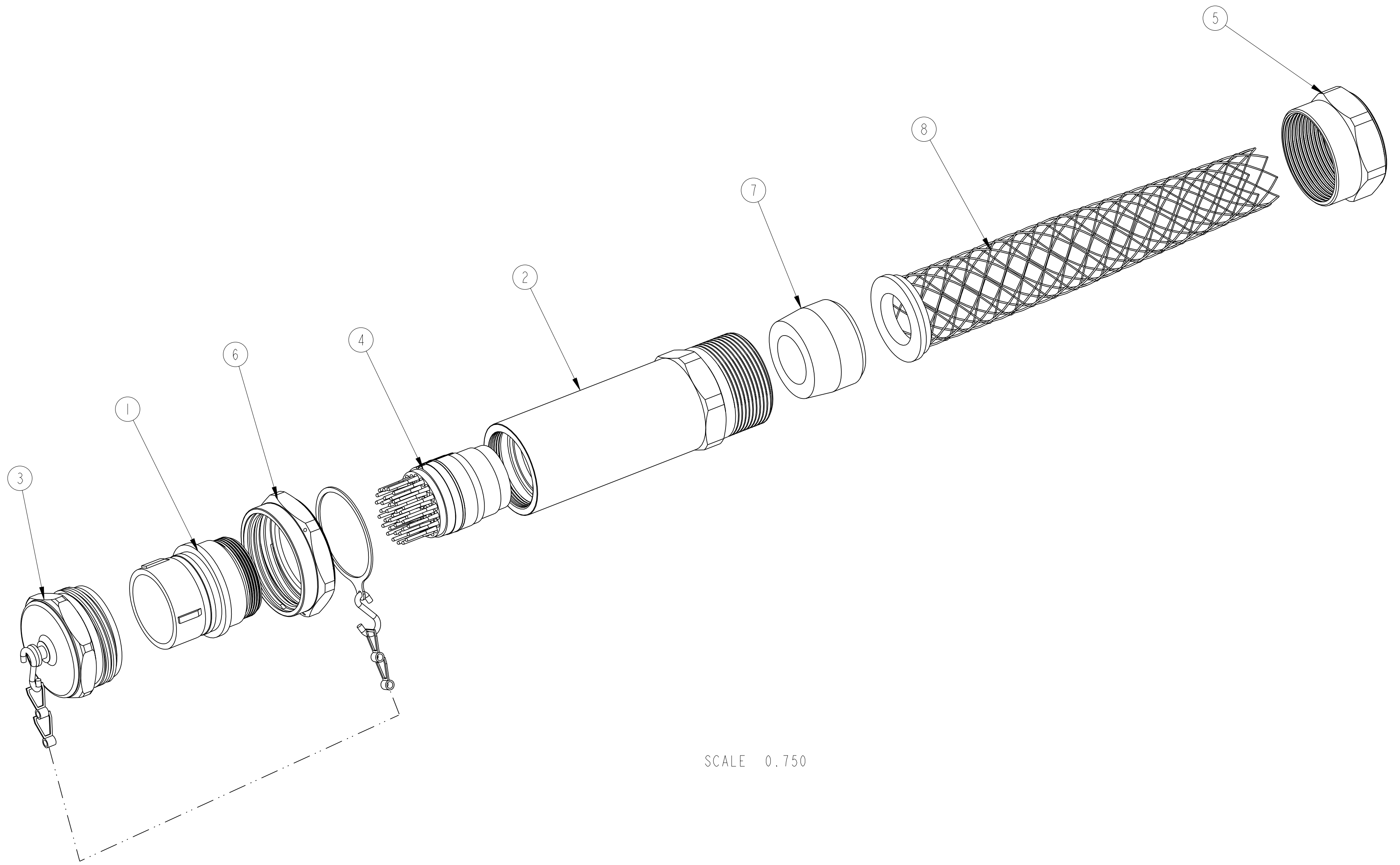

SCALE 0.750

THE USE OF THIS DOCUMENT IS UNLIMITED. HOWEVER, DOCUMENTS REFERENCED HEREON MAY CONTAIN LIMITED RIGHTS DATA.

RELEASED / Oct. 02 2006, 01:35 PM

SIZE C	CAGE CODE 77820	DOCUMENT NO. ZPEKL-( )-( )	REV. A
SCALE: 0.3		REF: ZPEKL-1416-321PN	SHEET 2 OF 2

3

2

1

# Mouser Electronics

Authorized Distributor

Click to View Pricing, Inventory, Delivery & Lifecycle Information:

[Amphenol:](#)

[ZPEKL-1216-355SN](#) [ZPEKL-34C28-42P](#) [ZPEKL-2020-38P](#)