

# MIL-ST Fiber Optic Connectors For Military & Commercial Use



**Amphenol**

 *Fiber Systems  
International*

# MIL-ST Connectors

## About Mil-ST Connectors

Amphenol Fiber Systems International (AFSI) offers rugged military fiber optic ST connectors for deployable and fixed communication systems. These connectors meet the stringent requirements of MIL-C-83522. AFSI's connectors are designed to provide the best possible optical performance in applications with severe environmental conditions.

The M83522 connector features a higher spring force than commercial ST connectors, allowing it to meet the shock and vibration requirements of MIL-C-83522. Stainless steel construction provides excellent mechanical strength and superior corrosion resistance. The boot is attached either by compression ring or by a threaded adapter.

US Navy approved Commercial-off-the-Shelf (COTS) ST connectors provide the same robustness with a spring force more consistent with commercial ST connectors. The COTS product is designed for use in shock-isolated environments, or to interface with commercial electronics and non-mil-spec ST adapters. It is also appropriate for applications where corrosion resistance and mechanical strength are desirable.

## Features and Benefits

- DFAR 252.225-7014 (Domestic Specialty Metals) compliant
- RoHS compliant
- Superior optical performance in extreme environmental conditions
- Super and Ultra PC polish capabilities
- Robust construction:
  - High grade stainless steel body (17-4 SS)
  - Zirconia ceramic ferrules and sleeves
  - Fungus-resistant, self-extinguishing boot
- Mil-qualified series: high spring force for shock and vibration resistance critical in military applications
- Navy approved COTS: for moderate shock and vibration environments



## Applications

- US Navy shipboard, surface and submarine, mission critical combat and communications systems
- Mobile tactical shelters
- Electronic battlefield networks
- Mobile emergency telecommunications stations
- Deployable outdoor, harsh environment

## Materials

- Ferrule: Zirconia
- Body: Stainless steel
- Boot: Fungus resistant, self-extinguishing thermoplastic

## MIL-C-83522 Connector Performance Specifications

### Specification

Insertion loss  
 Return loss  
 Tensile loading  
 Mating durability  
 Impact  
 Dust  
 Thermal shock  
 Vibration  
 Temperature humidity  
 Salt spray  
 Flammability  
 Temperature cycling  
 Shock  
 Fungus resistant

### Measurement Requirement

< 0.75 dB (MIL-C-83522 allows for <1.0 dB)  
 > 30 dB (multimode)  
 > 230 N  
 > 500 cycles  
 8 times, 1.5 meters  
 MIL-STD-202, Method 110  
 MIL-STD-1678, Method 4020  
 MIL-STD-1344, Method 2005  
 DOD-STD-1678, Method 4030  
 MIL-STD-1344, Method 1001  
 MIL-STD-1344, Method 1012  
 -55°C to 125°C Op, -65°C to +200°C Non-Op  
 MIL-STD-901D, Grade A, Type A, Class I  
 MIL-STD-810, Method 508

## ST Connector Typical Performance Specifications

### Specification

Insertion loss (typical)  
 Return loss

### Inspection Detail

EIA/TIA-455-34, Method A  
 EIA/TIA-455-107

### Single Mode

-0.2 dB  
 -50 dB

### Multimode

-0.3 dB  
 -30 dB

## Military ST Connector

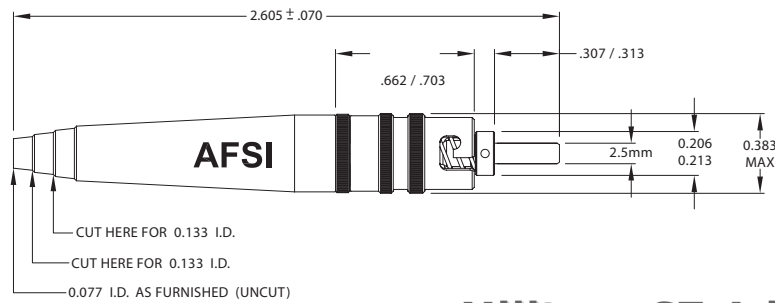

## Military ST Adapter

### Panel Cut-Out

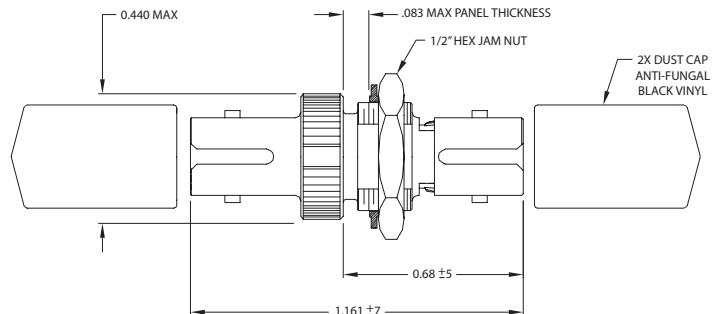
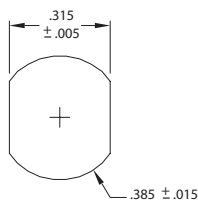

# MIL-ST Connectors

---

## Part Numbers & Descriptions

Description	MIL-SPEC Part Number	AFSI Part Number
MIL-ST Connector, MM, Compression Ring Boot	M83522/16DNX	MSTC1000
MIL-ST Connector, MM, Screw On Boot	M83522/16DNX	MSTC1001
MIL-ST Connector, SM, Compression Ring Boot	M83522/16DNY	MSTC2000
MIL-ST Connector, SM, Screw On Boot	M83522/16DNY	MSTC2001
MIL-ST Adapter, SM & MM	M83522/17NY	MSTA2000

## COTS Ordering Numbers

Description	COTS Numbers
COTS ST Connector, MM, Compression Ring Boot	MSTC1100
COTS ST Connector, MM, Screw On Boot	MSTC1101
COTS ST Connector, SM, Compression Ring Boot	MSTC2100
COTS ST Connector, SM, Screw On Boot	MSTC2101
ST Connector, MM, Closed Bayonet	MSTC1110

## How to Order

For more information on how to order or to obtain a price quote, please call us at 800.472.4225. For international calls please dial 1.214.547.2400 or email us at [info@fibersystems.com](mailto:info@fibersystems.com)

## About AFSI

Amphenol Fiber Systems International (AFSI) designs, manufactures, markets and supports reliable and innovative fiber optic interconnect solutions that withstand the harsh environments of military, oil & gas, mining and broadcast applications. After more than a decade in business, AFSI continues to uphold its position as a global leader in fiber optic interconnect components and systems such as termini, M28876, MIL-ST, TFOCA and the TFOCA-II<sup>®</sup> connector, which AFSI developed and patented. Altogether, AFSI has delivered millions of fiber optic connectors in more than 22 countries. Whenever there is a need for superior cost-effective fiber optic systems and products that will stand up to demanding operating environments, you can rely on AFSI for engineering know-how, top-quality products and expert technical support.

For more information about AFSI, please visit our web site at [www.fibersystems.com](http://www.fibersystems.com)

Amphenol Fiber Systems International, Inc.  
1300 Central Expressway North, Suite 100  
Allen, TX 75013  
Phone: 214.547.2400 - 800.472.4225  
Fax: 214.547.9344  
[www.fibersystems.com](http://www.fibersystems.com)  
[info@fibersystems.com](mailto:info@fibersystems.com)

# Mouser Electronics

Authorized Distributor

Click to View Pricing, Inventory, Delivery & Lifecycle Information:

[Amphenol:](#)

[MSTC1001](#) [MSTC2001](#) [MSTM1000-1](#)