

Portable reference source industrial monitoring kit

REF2510R

The ReferenceMate portable reference source enables users in the field to easily verify sensor performance and the integrity of the cabling between the sensor and the online system. A built-in reference accelerometer assures that a 1 g test level is maintained for sensors weighing up to 250 grams. Frequency of operation (61.4 Hz for imperial measurements, 100 Hz to confirm sensor calibration value, and 159.2 Hz for metric measurements) and measurement type (peak/RMS) are push button selected. The REF2510R kit includes all the accessories needed for simple vibration data collection.

LEDs notify the user when battery condition falls below operational levels or if the unit is overloaded. For calibration verification, reference test points are provided to verify the output of the internal sensor.

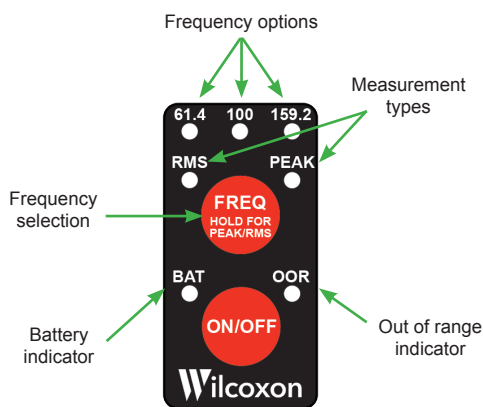

Front panel controls to make selections at the push of a button

Included in the REF2510R kit:

- Handheld shaker with protective boot
- 4x AA batteries
- Calibration sheet
- Belt clip
- Wrench
- Carrying case with foam insert
- 1/4-28 to 1/4-28 SF6 mounting stud



Key features

- Quickly and easily verify sensor operation and cable integrity in the field
- User-selectable operating frequency and measurement type (peak or RMS)
- Crossover frequencies for easy velocity verification
- Selections retained after powering off
- Rugged boot offers protection in harsh industrial environments
- Up to 40 hours of battery life
- Manufactured in an approved ISO 9001 facility

Certifications



Note: Due to continuous process improvement, specifications are subject to change without notice. This document is cleared for public release.

Portable reference source industrial monitoring kit

REF2510R

SPECIFICATIONS

Operating frequency ¹ , ±1.5%	61.4 Hz	100.0 Hz	159.2 Hz
Acceleration output ² , ±3%	1.0 g (9.81 m/s ²)	1.0 g (9.81 m/s ²)	1.0 g (9.81 m/s ²)
Velocity output ²	1.0 ips (25.4 mm/s)	0.61 ips (15.6 mm/s)	0.39 ips (9.8 mm/s)
Displacement output ²	2.6 mils (65.9 μm)	0.98 mils (24.8 μm)	0.39 mils (9.8 μm)
Operating cycles, 250 gram load ³	1,280	320	240
Mounting thread	1/4-28 female		
Mounting torque, max	10 in-lb (112 N-cm)		
Distortion, 100-250 gram load	≤7%		
Load, min to max	none to 8.8 oz (250 grams)		
Automatic switch off time	approx. 90 ± 10 sec defeatable		
Temperature range:			
Operating	-10° to +55°C (+15° to +130°F)		
Storage	-40° to +85°C (-40° to +185°F)		
Ramp-up time	≤3 sec		
Internal battery	4x AA alkaline batteries		
DC power	6 VDC ±5%, 1A, center positive		
Shaker dimensions	diameter: 2.59 in. (6.6 cm), height: 10.33 in. (26.2 cm)		
Weight, with batteries	900 grams (32 oz)		
Case material	6061 aluminum, black hard-coated anodized		
IP rating	IP54		
Boot material	thermoplastic rubber		

Notes: ¹ User-selectable.
² Peak or RMS.
³ Using supplied alkaline batteries.

Optional accessories: REF001 universal mounting kit; REF002 metric mounting kit; REF003 universal AC adaptor; MD055 two-pole magnet; TAA01 triaxial accelerometer angled adaptor

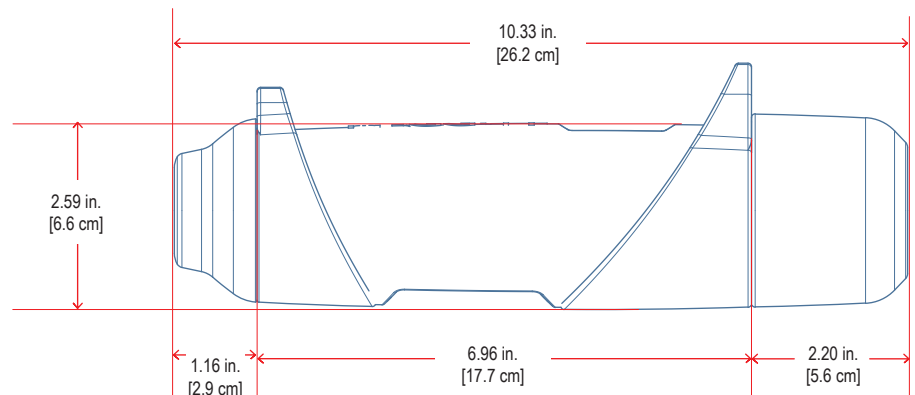
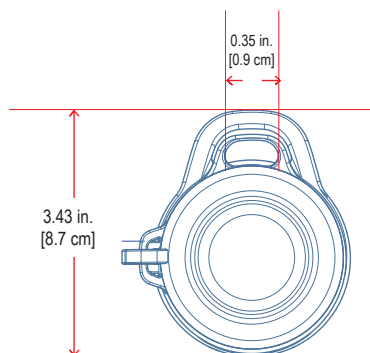

Note: Due to continuous process improvement, specifications are subject to change without notice. This document is cleared for public release.

Mouser Electronics

Authorized Distributor

Click to View Pricing, Inventory, Delivery & Lifecycle Information:

[Amphenol:](#)

[REF2510R](#)