

NOTES:

1. RECOMMENDED SOLDER INSTRUCTION SEE SHEET 2
2. METALSHELLS: COPPER ALLOY; min. 315µin TIN over 40-80µin NICKEL
3. INSULATORS: PBT GF UL 94 V-0; BLACK
4. CONTACTS: COPPER ALLOY
PLATING: 30µin HARD GOLD over min. 50µin NICKEL
5. THREADED LOCKS: COPPER ALLOY; min. 200µin TIN over 80µin NICKEL
6. COLLARS: COPPER ALLOY; min. 200µin TIN over 80µin NICKEL
7. STUD BOLTS / 4-40 UNC: STEEL; TIN PLATED
8. FRAME: ZINC DIE CAST; NICKEL PLATED
9. RUBBER GASKET: TPE; BLUE
10. O-RING: SILICON; BLUE
11. SEALING COMPOUND: PUR; BLUE
12. P.C.B. HOLE DRILLINGS AND RECOMMENDED PANEL CUT-OUT ON SHEET 2
13. RECOMMENDED TORQUE FOR MOUNTING SCREW
35Ncm (3.1 in.LB) / max.40Ncm (3.5 in.LB)
14. CONNECTOR IS PART MARKED: 6STD15PCR99B70A CONEC ABC

AT ALL TIMES WATER RESISTANT CONNECTORS NOT IN USE SHOULD BE COVERED WITH A CONEC WATER RESISTANT CAP OR WATER TIGHT HOOD.

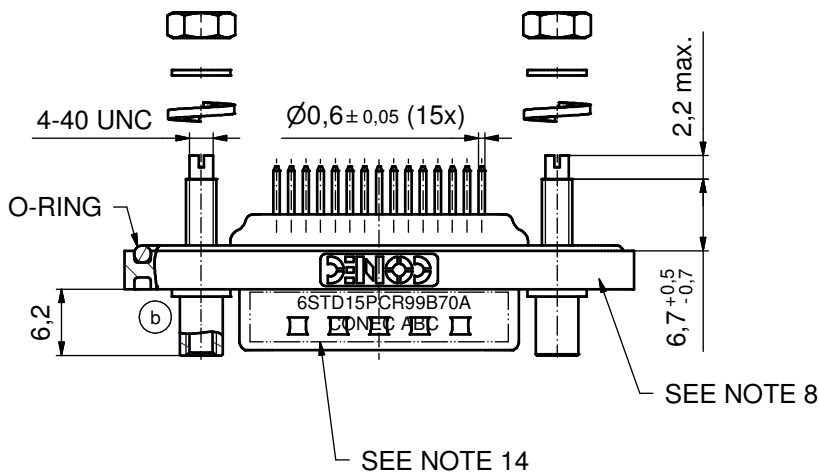
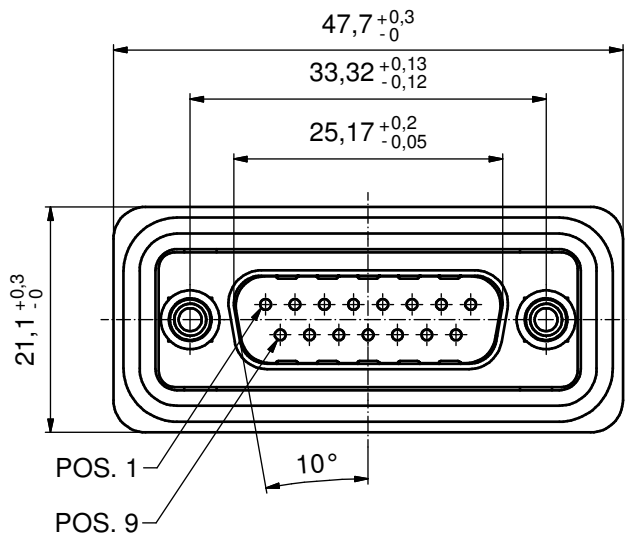

SEE NOTE 8

SEE NOTE 14

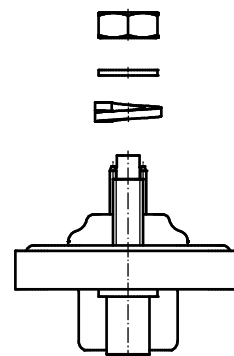
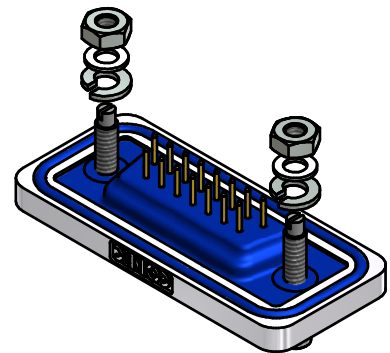
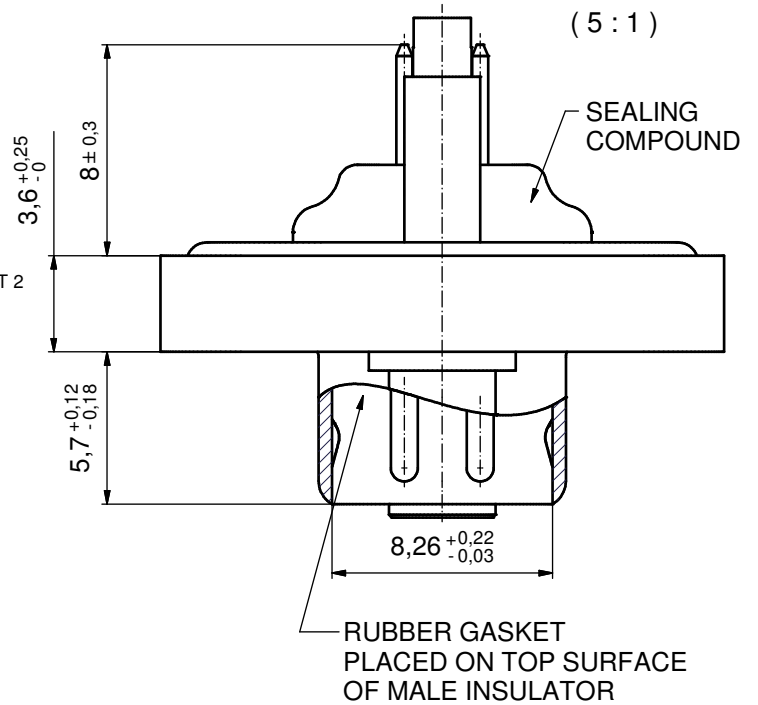

CONNECTOR WILL BE SUPPLIED WITH:
 2 x NUTS
 2 x FLAT WASHERS
 2 x SPRING WASHERS

Directive 2002/95/EC RoHS compliant

APPROVAL # FREIGABE # DEBLOCAGE # AUTORIZACION # APPROVAL	
CUSTOMER APPROVAL DATE:	
NAME:	TITLE:
COMPANY NAME:	
APPROVAL # FREIGABE # DEBLOCAGE # AUTORIZACION # APPROVAL	

THIS DRAWING MAY NOT BE COPIED OR REPRODUCED IN ANY WAY, AND MAY NOT BE PASSED ON TO A THIRD PARTY WITHOUT WRITTEN PERMISSION. OWNERSHIP AND COPYRIGHT OF CONEC GmbH			
DO NOT ALTER CAD DRAWING BY HAND			
1 x b	A5061	27.01.14	K.H.
a	Original		
rev.	description	date	name

tolerance		dim. in mm
date	name	
drawn	03.01.11	Henneboel
appd.	03.01.11	Fischer
norm		
d-old		

scale:	2:1 (5:1)	
material:	SEE NOTES	
title:	D-SUB MALE 15pos. SOLDER PIN STRAIGHT with threaded lock and 4-40 UNC stud bolt	
dwg no:	15K1A772	DIN-A3
part no:	6STD15PCR99B70A	sh:1/2



Solder Instruction

1. Insert contacts into the PCB.
2. Operate the soldering iron at 350°C, 50 Watt max. and use a pencil tip.
3. Put tip to solder wire and contact.
4. After 1 second bring in solder.
5. Heat for 3 seconds longer. Do not heat contact more than 4 seconds in total.
6. Remove soldering iron.
7. Wait until solder gets rigid again.
8. Do not solder adjacent contacts consecutively, alternate position within the connector to minimize heat build up.

P.C.B. HOLE DRILLINGS (P.C.B. TOP SIDE)

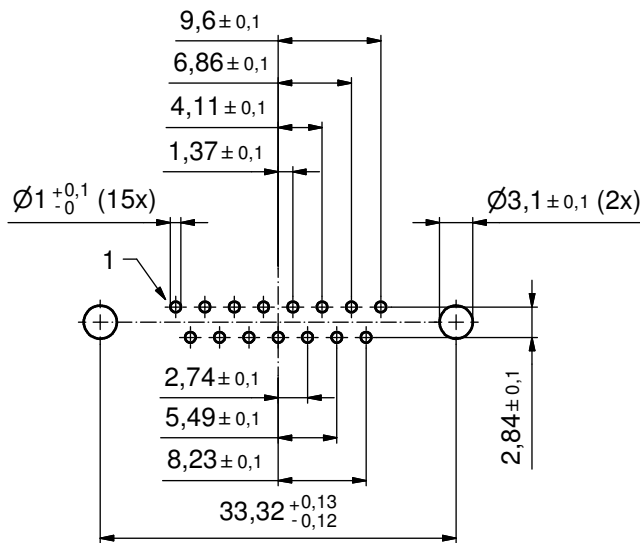

RECOMMENDED PANEL CUT-OUT

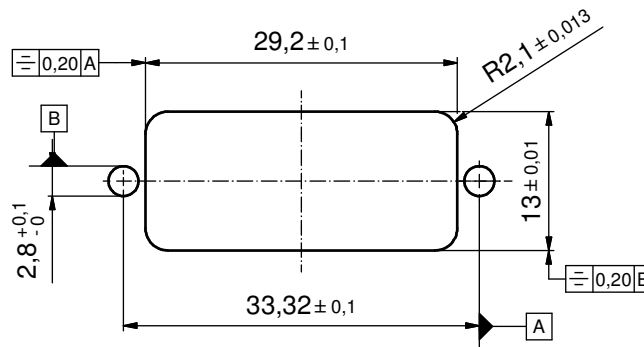

THIS DRAWING MAY NOT BE COPIED OR REPRODUCED IN ANY WAY, AND MAY NOT BE PASSED ON TO A THIRD PARTY WITHOUT WRITTEN PERMISSION. OWNERSHIP AND COPYRIGHT OF CONEC GmbH DO NOT ALTER CAD DRAWING BY HAND	tolerance		dim. in mm		scale: 3:1	
					material: SEE SHEET 1	
	drawn	03.01.11	Henneboel		title: P.C.B. HOLE DRILLINGS RECOMMENDED PANEL CUT-OUT D-SUB MALE 15pos. SOLDER PIN STRAIGHT	
	appd.	03.01.11	Fischer			
	norm					
	d-old					
	a	Origin			dwg no: 15K1A772	DIN-A3
	rev.	description			date	name
					part no: SEE SHEET 1	

Mouser Electronics

Authorized Distributor

Click to View Pricing, Inventory, Delivery & Lifecycle Information:

[Amphenol:](#)

[6STD15PCR99B70A](#)