

NOTES:

1. MATERIALS AND FINISHES:
 BODY & COUPLING NUT - BRASS, SILVER PLATING
 CONTACT - BRASS, GOLD PLATING
 OUTER CONTACT - BeCu, SILVER PLATING
 CONTACT - PHOSPHOR BRONZE, GOLD PLATING
 RETAINING RING - PHOSPHOR BRONZE, NATURAL
 GASKET - SILICONE RUBBER, RED
 FERRULE - COPPER, SILVER PLATING
 INSULATORS - PTFE, NATURAL

2. ELECTRICAL:
 A. IMPEDANCE: 50 OHM
 B. FREQUENCY RANGE: DC - 11 GHz

3. MECHANICAL:
 A. DURABILITY: 500 CYCLES MIN.
 B. TEMPERATURE RANGE: -65°C TO +165°C

4. PACKAGING:
 A. QUANTITY: SINGLE PACK
 B. MARKING: BAG TO BE MARKED
 "AMPHENOL RF, 82-4474, AND DATE CODE"

5. CABLE ASSEMBLY INSTRUCTIONS:
 A. TRIM CABLE AS SHOWN.
 B. INSERT CABLE CENTER CONDUCTOR TO CONTACT.
 C. SOLDER CONTACT TO CABLE OR CRIMP CONTACT TO CABLE.
 D. CRIMP WITH AMPHENOL TOOL 227-944 (M22520/5-01) AND
 DIE SET 227-1221-25 CAVITY B (M22520/5-25 CLOSURE B) (0.100 HEX)
 E. CRIMP WITH AMPHENOL TOOL 227-944 (M22520/5-01) AND
 DIE SET 227-1221-25 CAVITY A (M22520/5-25 CLOSURE A) (0.429 HEX)

6 SHOWS CABLE ENTRY DIMENSIONS.

THIRD ANGLE PROJ.

REVISIONS

REV	DESCRIPTION	DATE	ECO	APPR
--	RELEASE TO MFG.	--	--	--
W	DESIGN UPDATED	18-Oct-18	09423	BEW

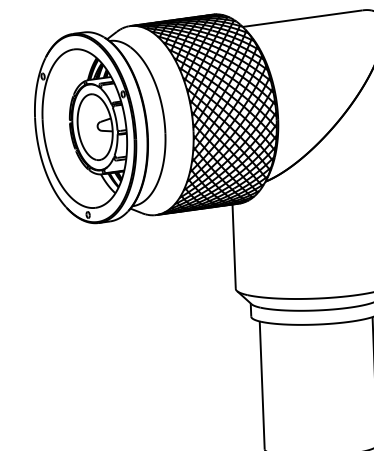

SCALE 1.200

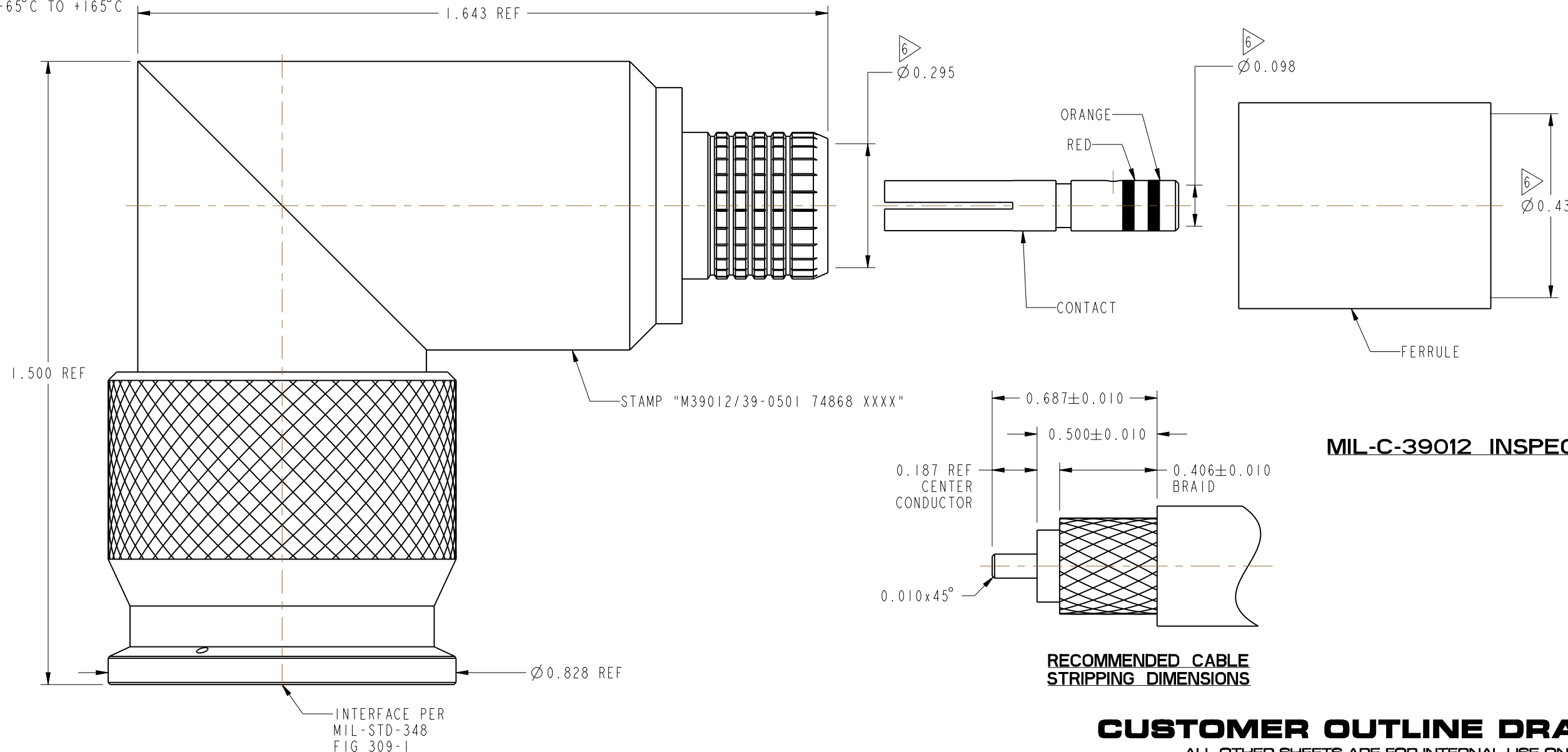

MIL-C-39012 INSPECTION

RECOMMENDED CABLE STRIPPING DIMENSIONS

CUSTOMER OUTLINE DRAWING

ALL OTHER SHEETS ARE FOR INTERNAL USE ONLY

UNLESS OTHERWISE SPECIFIED, DIMENSIONS ARE IN INCHES AND TOLERANCES ARE: 2 PLACE DECIMAL 3 PLACE DECIMAL ANGLES ±.015 (0,381 mm) ±.005 (0,127 mm) ± 1°	MATERIAL	DRAWN	DATE	TITLE		Amphenol RF www.amphenolrf.com
	SEE NOTES	A ARUN PRABU	30-Mar-16	SC RA PLUG MIL-CRIMP (CATEGORY D) FOR RG 9, 214, 225, 393/U CABLE		
	REFERENCE	ENGINEER	DATE	SCALE: 3.5:1.0 SHEET 2 OF 2		DRAWING NO.82-4474
	M39012/39-0501 & DOR 309266-51	K. CAPOZZI	30-Mar-16	DWG SIZE	REV	ITEM NO.82-4474
CONFIGURATION LEVEL: In Work	APPROVED	DATE	B	W	PART NO.82-4474	
FINISH	K. CAPOZZI					

NOTICE - These drawings, specifications, or other data (1) are, and remain the property of Amphenol corp. (2) must be returned upon request; and (3) are confidential and not to be disclosed to any person other than those to whom they are given by Amphenol Corp. the furnishing of these drawings, specifications, or other data by Amphenol Corp., or to any other person to anyone for any purpose is not to be regarded by implication or otherwise in any manner licensing, granting rights to permitting such holder or any other person to manufacture, use or sell any product, process or design, patented or otherwise, that may in any way be related to or disclosed by said drawings, specifications, or other data.

Mouser Electronics

Authorized Distributor

Click to View Pricing, Inventory, Delivery & Lifecycle Information:

[Amphenol:](#)

[082-4474](#)