

NOTES:

1. MATERIALS AND FINISHES:

- FERRULE - BRASS, NICKEL PLATING
- HEX NUT - BRASS, NICKEL PLATING
- LOCK WASHER - BRASS, NICKEL PLATING
- BODY - BRASS, NICKEL PLATING
- CONTACT - BRASS, GOLD PLATING
- GASKET - SILICONE RUBBER, RED
- SLEEVE - DELRIN, NATURAL
- INSULATOR - PTFE, NATURAL

2. ELECTRICAL:

- A. IMPEDANCE: 50 OHM
- B. FREQUENCY RANGE: 0-11 GHz
- C. DIELECTRIC WITHSTANDING VOLTAGE: 1500 VRMS, MIN.

3. MECHANICAL:

- A. DURABILITY: 500 CYCLES MIN.
- B. TEMPERATURE RANGE: -40°C TO +85°C

4. CRIMPED FERRULE HEX CRIMP SIZE .178"

5. CRIMPED CONTACT PIN HEX CRIMP SIZE .068"

6. MAX. PANEL THICKNESS=3.5 MM

7 SHOWS CABLE ENTRY DIMENSIONS.

THIRD ANGLE PROJ.

REVISIONS

REV	DESCRIPTION	DATE	ECO	APPR
NC	INITIAL RELEASE	16-Sep-09	----	CW
B	SYNC, REDRAWN IN THE PRO/E	02-Feb-18	06782	SH

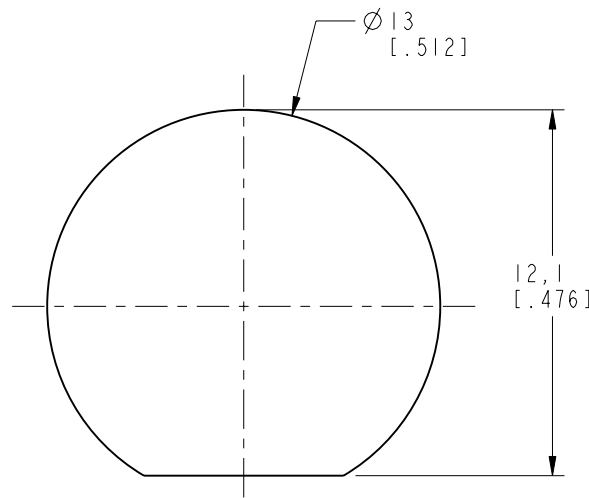

RECOMMENDED MOUNTING HOLE

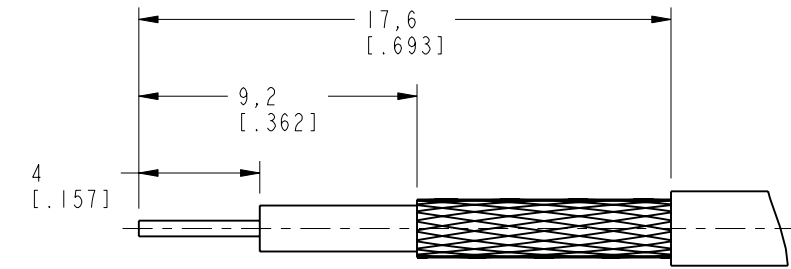

RECOMMENDED CABLE STRIPPING DIM'S

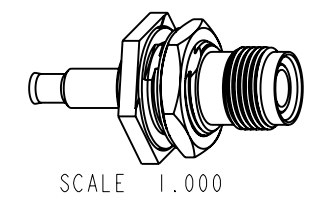

SCALE 1.000

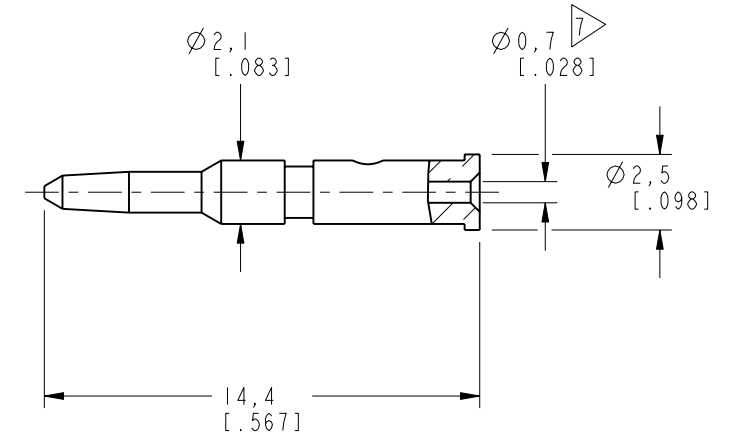
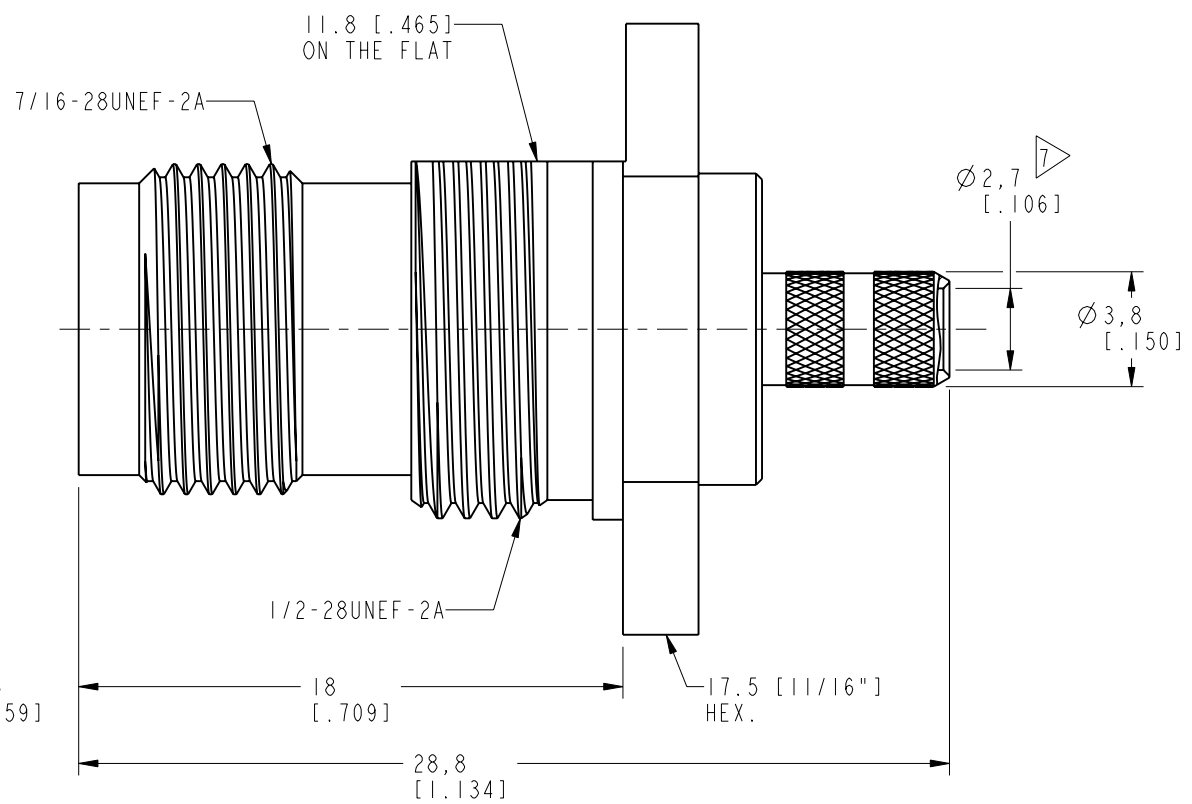
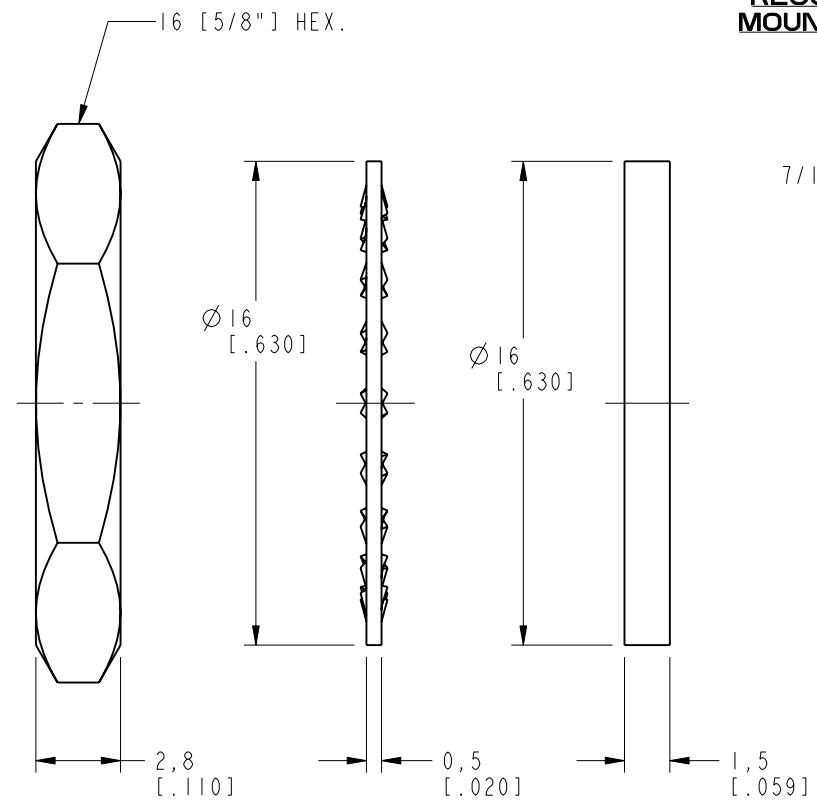
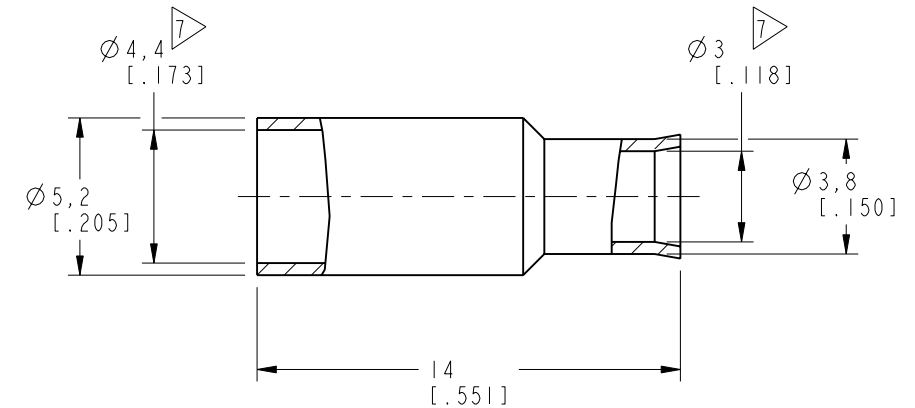
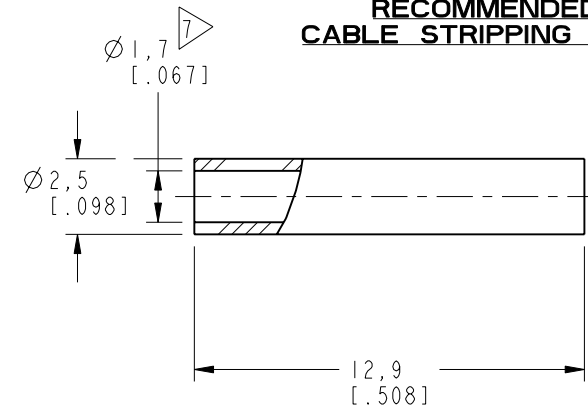

CUSTOMER OUTLINE DRAWING
ALL OTHER SHEETS ARE FOR INTERNAL USE ONLY

UNLESS OTHERWISE SPECIFIED, DIMENSIONS ARE IN METRIC AND TOLERANCES ARE:
 <0.5mm ±0.05mm 0.5 - 6mm ±0.1mm 6 - 30mm ±0.2mm 30 - 120mm ±0.3mm ANGLES ±1°

NOTICE - These drawings, specifications, or other data (1) are, and remain the property of Amphenol corp. (2) must be returned upon request; and (3) are confidential and not to be disclosed to any person other than those to whom they are given by Amphenol Corp. the furnishing of these drawings, specifications, or other data by Amphenol Corp., or to any other person to anyone for any purpose is not to be regarded by implication or otherwise in any manner licensing, granting rights to permitting such holder or any other person to manufacture, use or sell any product, process or design, patented or otherwise, that may in any way be related to or disclosed by said drawings, specifications, or other data.

MATERIAL	-
REFERENCE AND CONFIGURATION LEVEL:	In Work
FINISH	-

DRAWN	M. ZHANG	DATE	02-Feb-18
ENGINEER	TONY	DATE	31-May-00
APPROVED	S. HSIEH	DATE	02-Feb-18
CAD FILE			

TITLE		TNC REVERSE POLARITY BULKHEAD CRIMP JACK	
SCALE:	4.0:1.0	SHEET	2 OF 2
DWG SIZE	B	REV	B

Amphenol RF	
www.amphenolrf.com	
DRAWING NO.	T87052302-NT3G
ITEM NO.	526421ABD00NA5F
PART NO.	122192RP

Mouser Electronics

Authorized Distributor

Click to View Pricing, Inventory, Delivery & Lifecycle Information:

[Amphenol:](#)

[122192RP](#)