



T H E R M O M E T R I C S
A C O M M I T M E N T T O E X C E L L E N C E

Coolant Temperature Sensor (CTS) WTF083B001



Thermometrics Coolant Temperature Sensor (CTS) monitors the temperature of the coolant that is being pumped around the battery to cool the battery module in Electric Vehicles (EV) and Plug-in Hybrid Electric Vehicles (PHEV). The purpose of this sensor is to relay signal to the battery management system (BMS) in the event of overheating. Should this happen, the vehicle can be stopped and the charging switched off before the heat causes any permanent damage to the battery.

Applications

- Battery Coolant Temperature
- HVAC Refrigerant Temperature

Features

- IP67 Compliant
- Compact design with integrated connector
- Customizable to meet application installation needs
- Variety of RvT curves and terminal plating available
- Operating Temperature Range: -40°C ~ 100°C
- Fast response

Amphenol
Advanced Sensors

CTS Specifications

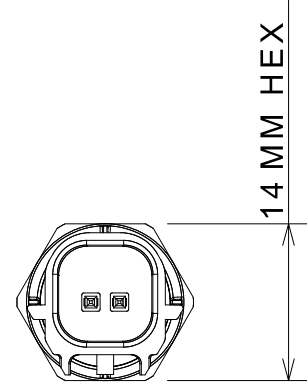
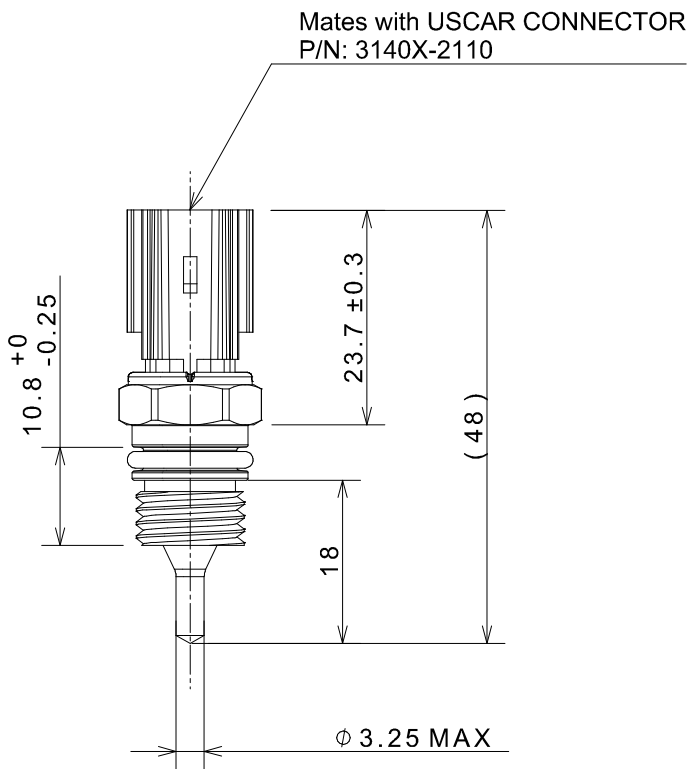

- Part Number : WTF083B001
- Operating Temperature Range: -40°C~ 100°C
- Storage Temperature Range: -40°C~ 125°C
- R@25 °C: 2825Ω ± 1.3%
- Response Time : 5 Seconds from 25 °C to 85 °C in water
- Temperature Accuracy: R@25 °C ± 0.3°C
- Housing Material
 - : PBT-GF15% Connector with 14mm Hex
 - Machined 12L14 Steel, Zinc with trivalent chromium
- Beta(25/85) °C: 3975K ± 0.75%
- Connector: USCAR 064 Sealed(IP67)
- Matching connector: USCAR 3140x-2110

R vs. T					
Temp. (°C)	Resistance (Ω)	Resistance Accuracy		Temperature Accuracy	
		-%	+%	+°C	-°C
-40	94331	-3.9	4.0	0.58	-0.61
-35	68175	-3.6	3.7	0.57	-0.59
-30	49796	-3.4	3.5	0.55	-0.57
-25	36743	-3.2	3.3	0.53	-0.55
-20	27377	-3.0	3.0	0.51	-0.52
-15	20590	-2.8	2.8	0.49	-0.50
-10	15626	-2.6	2.6	0.47	-0.48
-5	11960	-2.4	2.4	0.45	-0.46
0	9231	-2.2	2.2	0.43	-0.43
5	7180	-2.0	2.0	0.40	-0.41
10	5628	-1.8	1.8	0.38	-0.38
15	4444	-1.6	1.6	0.35	-0.35
20	3533	-1.5	1.5	0.32	-0.33
25	2828	-1.3	1.3	0.30	-0.30
30	2278	-1.5	1.5	0.34	-0.34
35	1847	-1.6	1.6	0.39	-0.39
40	1506	-1.8	1.8	0.44	-0.44
45	1235	-1.9	1.9	0.49	-0.49
50	1018	-2.1	2.1	0.54	-0.55
55	844	-2.2	2.2	0.59	-0.60
60	703	-2.3	2.4	0.65	-0.66
65	589	-2.5	2.5	0.70	-0.71
70	495	-2.6	2.6	0.76	-0.77
75	418	-2.7	2.8	0.81	-0.83
80	355	-2.8	2.9	0.87	-0.89
85	303	-2.9	3.0	0.93	-0.95
90	259	-3.1	3.1	0.99	-1.02
95	222	-3.2	3.3	1.05	-1.08
100	192	-3.3	3.4	1.12	-1.15

Mouser Electronics

Authorized Distributor

Click to View Pricing, Inventory, Delivery & Lifecycle Information:

[Amphenol:](#)

[WTF0803B001](#) [WTF083B001](#)