



Mini Coax connector



General information

Design	according to IEC 61076-4-100		
No. of contacts	2,4,6,8 or 10 for board connectors	1-10 for cable connectors	
Grid pattern	4,40mm x 6,25mm (within a twin x between twins) 8,80mm for Mini Coax single-row connectors (between lines)		
Test voltage	max. 1000V for 60s		
Contact resistance	centre contact max. 12mOhm ground contact max. 6mOhm		
Insulation resistance	min. 50Ohm		
Power	max. 40W (at 2,5Ghz)		
Frequency range	DC ... 2,5GHz		
Nominal impedance	500hm		
Return loss	max. -20dB		
VSWR	max. 1,2 (DC ... 2,5GHz for the connector interface with suitable termination)		
Insertion loss	max. 0,25 dB (DC ... 2,5GHz for the connector interface only)		

Near end cross talk (NEXT)	Pin distance	Board-to-Board	Board-to-Cable	Cable-to-Cable
	$\Delta x = 4,40\text{mm}$		50dB	60dB
$\Delta x = 6,25\text{mm}$		60dB	70dB	90dB
$\Delta x = 7,64\text{mm}$		75dB	80dB	90dB
$\Delta x = 8,80\text{mm}$		-	75dB	-
$\Delta x = 12,50\text{mm}$		90dB	90dB	90dB

Temperature range	-55°C ... +125°C		
Termination technology	press-in		
Mating force	max. 10N per line		
Withdrawal force	min. 1N per line		
Mating cycles	500		
Mating distance	12,5mm ... 15mm		
Wiping length	2,5mm		
Acceptable radial mating offset	max. 1,5mm; max. angle 0,5° (for mounting with HARTING counterpart)		
PCB thickness	daughtercard	1,4mm - 3,2mm	
	backplane	1,6mm - 8,0mm	
UL file	E102079		
RoHS - compliant	Yes		
Leadfree	Yes		

Insulator material

Material	LCP (Liquid Cristal Polymer)
Color	nature
UL classification	UL 94-V0
Material group acc. IEC 60664-1	IIIa (175 ≤ CTI < 400)

Contact material

Contact material	Copper alloy
Plating termination zone	Ni for ground pin, Au for centre pin
Plating contact zone	Au over Ni

Cable connectors

Cable connectors are fully assembled on Mini Coax side by HARTING, free conductors side can also be assembled by customer

Recommended configuration of plated through holes for press-in termination

In addition to the hot-air-level (HAL), other PCB surfaces are getting more important. Due to their different properties - such as mechanical strength and coefficient of friction - we recommend the following configuration of PCB through holes.

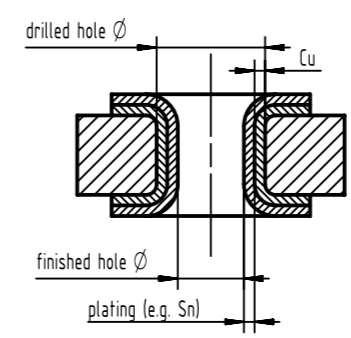

Material	Drilled hole Ø	Plated hole Ø	Thickness
Tin plated PCB (HAL) acc. to EN 60352-5	1,15±0,025 mm		
	Cu		min. 25µm
	Sn		max. 15µm
Chemical tin plated PCB	1,15±0,025mm		
	Cu		min. 25µm
	Sn		min. 0,8mm
Gold /Nickel plated PCB	1,15±0,025mm		
	Cu		min. 25µm
	Ni		3 - 7µm
Silver plated PCB	1,15±0,025mm		
	Cu		min. 25µm
	Ag		0,1 - 0,3µm
Copper plated PCB (OSP)	1,15±0,025mm		
	Cu		min. 25µm
			1,00 - 1,10mm

Technical background - definition of a HARTING coaxial connection

Mini Coax standard straight = female = jack for backplane
Mini Coax standard angled = male = plug for daughtercards

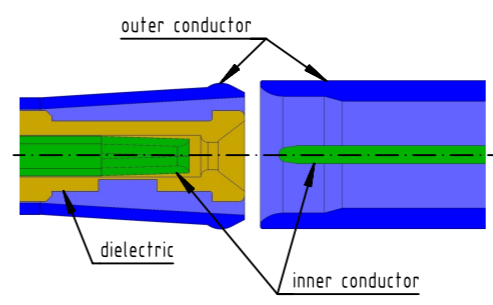

Mating male and female

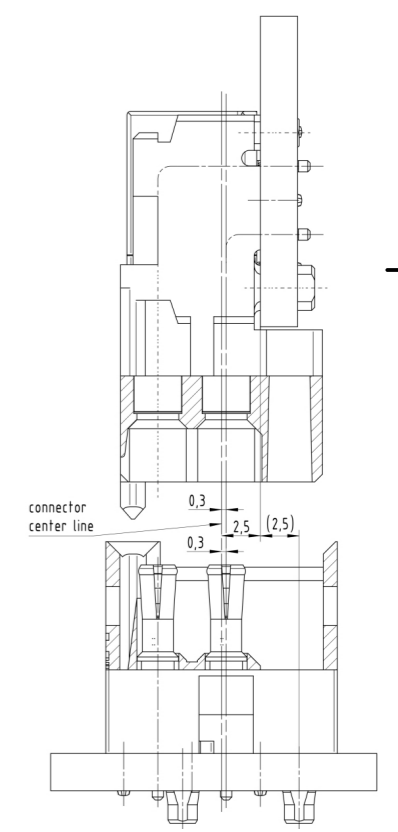

PCB layout for Ground and Signal contacts

Grounding pins per module connected with one-piece plate. 'Ground' for these pins to be layouted as one PCB-layer, 'Signal' to be traced individually on separate PCB-layer.

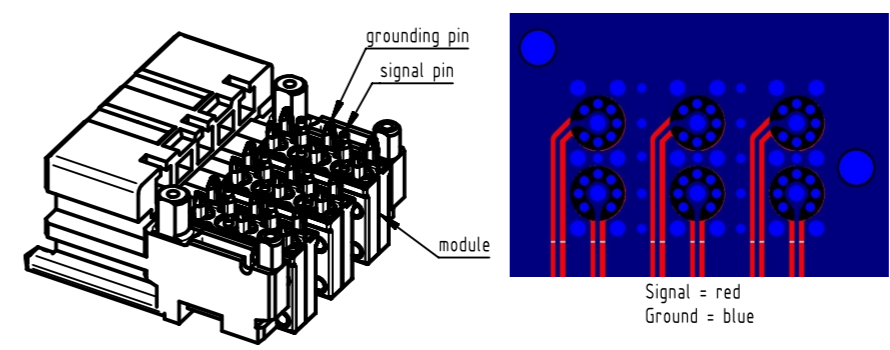

	All Dimensions in mm Original Size DIN A3	Scale 1:1	Free size tol.	Ref. Sub.
	All rights reserved Department EL PD	Created by STORCK	Inspected by DAHMS	Standardisation 302077
HARTING Electronics GmbH D-32339 Espelkamp		Title Mini Coax connector	Date 2020-10-15	State Final Release
		Type DS	Number 07010000101	Doc-Key / ECM-Nr. 100568364/UGD/001/C 500000181362
				Rev. C Page 1/1

Mouser Electronics

Authorized Distributor

Click to View Pricing, Inventory, Delivery & Lifecycle Information:

HARTING:

[07111000024](#) [07111000026](#) [07119000023](#) [07119000024](#) [07311000019](#) [07311000020](#) [07311000021](#)
[07111000023](#) [07311000028](#)