

Push - Pull Audiophile - Output (1608-1650 Series)

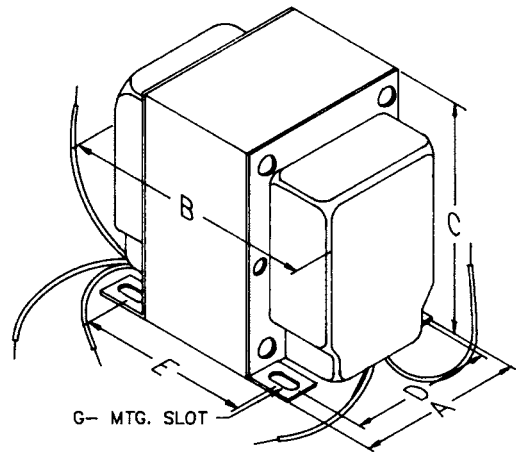

PUSH - PULL "CLASSIC" TUBE TYPE - ULTRA-LINEAR OUTPUT TRANSFORMERS

Tube Audio

- Designed for push-pull tube output circuits.
- Enclosed (shielded), 4 slot, above chassis Type "X" mounting.
- Frequency response 30 Hz. to 30 Khz. at full rated power (+/- 1 db max. - ref. 1 Khz) minimum. Except the 1650E (70 Hz. to 30 Khz. +/- 1 db max. - ref. 1 Khz.)
- Insulated flexible leads 8" min.
- Due to the unique interleaving of the windings BOTH secondary windings must be engaged to meet specifications (see hook-up schematics).
- Negative feedback circuits can be utilized by connecting to the Green & Black wires - 4 Ohm secondary (this winding is always engaged on all load configurations).
- All units include 40% screen taps for Ultra-Linear operation (if desired).
- Typical applications - Push-Pull: triode, Ultra-Linear pentode, and tetrode connected audio output.
- For our NEW improved "easy hook-up" secondary series - see our 1608-1650 "A" series.
- For the "ultimate" in Push-Pull output see our line of epoxy potted output transformers (1650 potted series).

Part Number	Audio Watts (RMS)	Primary Impedance	Max. DC Per Side	Secondary Impedance	Dimensions (Inches)						Wt. Lbs.
					A	B	C	D	E +/- 1/16"	G Slot	
1608	10	8,000 C.T.	100 ma.	4-8-16	2.50	2.75	3.06	2.00	1.69	.203 x .38	2.5
1609	10	10,000 C.T.	100 ma.	4-8-16	2.50	2.75	3.06	2.00	1.69	.203 x .38	2.5
1615	15	5,000 C.T.	100 ma.	4-8-16	2.50	3.25	3.06	2.00	2.19	.203 x .38	3.25
1620	20	6,600 C.T.	158 ma.	4-8-16	2.50	3.50	3.06	2.00	2.44	.203 x .38	3.5
1650F	25	7,600 C.T.	128 ma.	4-8-16	2.50	3.50	3.06	2.00	2.44	.203 x .38	4
1645	30	5,000 C.T.	128 ma.	4-8-16-70 V	2.50	3.75	3.06	2.00	2.69	.203 x .38	4.5
1650H	40	6,600 C.T.	200 ma.	4-8-16	3.13	4.00	3.81	2.50	2.69	.203 x .38	6.5
1650K	50	3,400 C.T.	318 ma.	4-8-16	3.13	4.00	3.81	2.50	2.69	.203 x .38	7
1650N	60	4,300 C.T.	318 ma.	4-8-16	3.13	4.25	3.81	2.50	2.94	.203 x .38	8
1650P	60	6,600 C.T.	200 ma.	4-8-16	3.13	4.25	3.81	2.50	2.94	.203 x .38	8
1650R	100	5,000 C.T.	318 ma.	4-8-16	3.75	4.25	4.56	3.00	3.06	.203 x .38	12
1650T	120	1,900 C.T.	403 ma.	4-8-16	3.75	4.50	4.56	3.00	3.31	.203 x .38	14
1650W	280	1,900 C.T.	806 ma.	4-8-16	4.38	7.50	5.25	3.50	5.88	.203 x .38	28



CANADA
Guelph, Ontario (519) 822-2960
St. Laurent, Quebec (514) 343-9010
USA
Cheektowaga, NY (716) 630-7030

www.hammondmfg.com



EUROPE
Basingstoke, UK 01256 812812

AUSTRALIA
Queenstown, Australia 61-8-8240-2244

Push - Pull Audiophile - Output (1608-1650 Series)

Suggested Tube Types

Part Number	Audio Watts (RMS)	Primary Impedance	Operation	Tube Types
1608	10	8,000 C.T.	Push-Pull (2 Tubes)	6AQ5, 6V6, 6BQ5, EL84, SV83
1609	10	10,000 C.T.	Push-Pull (2 Tubes)	6AQ5, 6V6, 6BQ5, EL84, SV83
1615	15	5,000 C.T.	Push-Pull (2 Tubes)	2A3, 6A3, 6AQ5, 6B4G, 6L6, 6V6
1620	20	6,600 C.T.	Push-Pull (2 Tubes)	6AQ5, 6L6, 6V6
1650F	25	7,600 C.T.	Push-Pull (2 Tubes)	6L6GC, 6V6, 807, 5881, EL34
1645	30	5,000 C.T.	Push-Pull (2 Tubes)	6L6GC, 6V6, 807, 5881, EL34
1650H	40	6,600 C.T.	Push-Pull (2 Tubes)	6L6GC, 807, 5881, EL34
1650K	50	3,400 C.T.	Push-Pull Par. (4 Tubes)	6L6GC, 807, 5881, EL34, 6146B, 6550B
1650N	60	4,300 C.T.	Push-Pull Par. (2 or 4 Tubes)	6L6GC, 807, 5881, EL34, 6146B, 6550B, KT88
1650P	60	6,600 C.T.	Push-Pull (2 Tubes)	6L6GC, 807, 5881, EL34, 6146B, 6550B, KT88
1650R	100	5,000 C.T.	Push-Pull Par. (2 or 4 Tubes)	807, 5881, EL34, 6146B, 6550B, KT88
1650T	120	1,900 C.T.	Push-Pull Par. (4 or 6 Tubes)	6L6GC, 5881, EL34, 6550B, KT88
1650W	280	1,900 C.T.	Push-Pull Par. (6 or 8 Tubes)	6L6GC, 5881, EL34, 6550B, KT88

Note: The above examples of possible combinations are to help you narrow down the choices of transformers for your favorite tube types. How you operate the tubes (push-pull, push-pull parallel, ultra-linear, class, B+, bias, operating points, etc.) will change optimum plate to plate load impedance. Only a few of the most popular tubes are shown. As more tubes become available we will add them to the list. A tube manual or tube manufacturer's technical data sheets should be consulted first, before making a decision on a proper output transformer.

Schematic - All Parts Except 1645

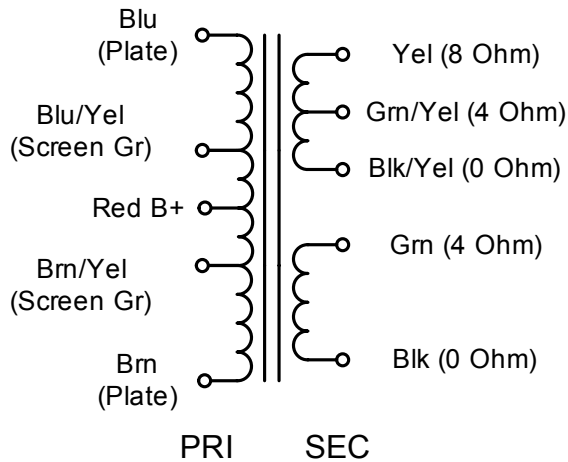

Schematic - 1645 Only

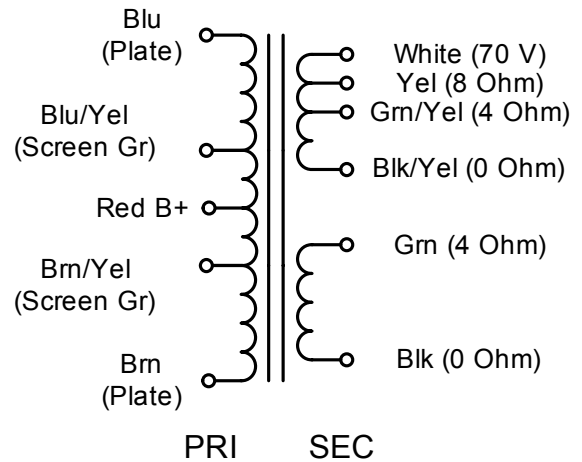

Note: To hook up 4/8/16 ohm secondary loads, see "Secondary Hook-Up Data" below. To hook up secondary to 70V loads, jumper Blk/Yel wire to Grn wire. Connect load to Blk and White wires.

Secondary Hook-Up Data

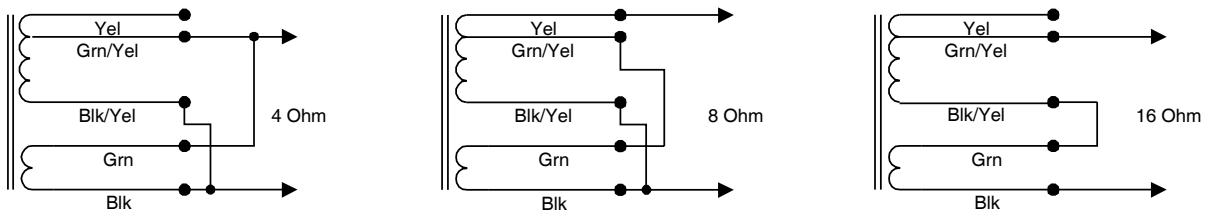

NOTE: Due to the unique interleaving of the windings BOTH secondary windings must be engaged (as shown) to meet specifications

EUROPE

Basingstoke, UK 01256 812812

AUSTRALIA

Queenstown, Australia 61-8-8240-2244

www.hammondmfg.com



CANADA

Guelph, Ontario (519) 822-2960
St. Laurent, Quebec (514) 343-9010

USA

Cheektowaga, NY (716) 630-7030



Push - Pull Audiophile - Output (1608-1650 "A" Series)

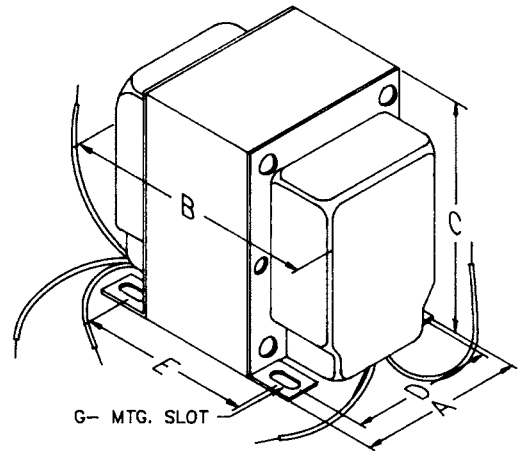

PUSH - PULL "EASY HOOK-UP" "CLASSIC" TUBE TYPE - ULTRA-LINEAR OUTPUT TRANSFORMERS

- NEW & Improved version of our 1608-1650 series output transformers (re-designed secondaries for easy hook-up of secondary loads)
- Designed for push-pull tube output circuits.
- Enclosed (shielded), 4 slot, above chassis Type "X" mounting.
- Frequency response 30 Hz. to 30 KHz. at full rated power (+/- 1 db max. - ref. 1 KHz) minimum. Except the 1650E (70 Hz. to 30 KHz. +/- 1 db max. - ref. 1 KHz.)
- Insulated flexible leads 8" min.
- All units (except the 1650G) include 40% screen taps for Ultra-Linear operation (if desired).
- Typical applications - Push-Pull: triode, Ultra-Linear pentode, and tetrode connected audio output. The 1650G does NOT have primary screen taps and will not support "Ultra-Linear" applications.

Tube Audio

Part Number	Audio Watts (RMS)	Primary Impedance	Max. DC Per Side	Secondary Impedance	Dimensions (Inches)						Wt. Lbs.
					A	B	C	D	E +/- 1/16"	G Slot	
1608A	10	8,000 C.T.	100 ma.	4-8-16	2.50	2.75	3.06	2.00	1.69	.203 x .38	2.5
1609A	10	10,000 C.T.	100 ma.	4-8-16	2.50	2.75	3.06	2.00	1.69	.203 x .38	2.5
1615A	15	5,000 C.T.	100 ma.	4-8-16	2.50	3.25	3.06	2.00	2.19	.203 x .38	3.25
1650E	15	8,000 C.T.	100 ma.	4-8-16	2.50	3.25	3.06	2.00	2.50	.203 x .38	3.5
1620A	20	6,600 C.T.	158 ma.	4-8-16	2.50	3.50	3.06	2.00	2.44	.203 x .38	3.5
1650FA	25	7,600 C.T.	128 ma.	4-8-16	2.50	3.50	3.06	2.00	2.44	.203 x .38	4
1645A	30	5,000 C.T.	128 ma.	4-8-16-70 V	2.50	3.75	3.06	2.00	2.69	.203 x .38	4.5
1650G	35	6,600 C.T.	200 ma.	3.5/8/16/250/500	3.13	3.75	3.81	2.50	2.25	.203 x .38	5
1650HA	40	6,600 C.T.	200 ma.	4-8-16	3.13	4.00	3.81	2.50	2.69	.203 x .38	6.5
1650KA	50	3,400 C.T.	318 ma.	4-8-16	3.13	4.00	3.81	2.50	2.69	.203 x .38	7
1650NA	60	4,300 C.T.	318 ma.	4-8-16	3.13	4.25	3.81	2.50	2.94	.203 x .38	8
1650PA	60	6,600 C.T.	200 ma.	4-8-16	3.13	4.25	3.81	2.50	2.94	.203 x .38	8
1650RA	100	5,000 C.T.	318 ma.	4-8-16	3.75	4.25	4.56	3.00	3.06	.203 x .38	12
1650TA	120	1,900 C.T.	403 ma.	4-8-16	3.75	4.50	4.56	3.00	3.31	.203 x .38	14
1650WA	280	1,900 C.T.	806 ma.	4-8-16	4.38	7.50	5.25	3.50	5.88	.203 x .38	28



CANADA
Guelph, Ontario (519) 822-2960
St. Laurent, Quebec (514) 343-9010
USA
Cheektowaga, NY (716) 630-7030

www.hammondmfg.com



EUROPE
Basingstoke, UK 01256 812812

AUSTRALIA
Queenstown, Australia 61-8-8240-2244

Push - Pull Audiophile - Output (1608-1650 "A" Series)

Suggested Tube Types

Part Number	Audio Watts (RMS)	Primary Impedance	Operation	Tube Types
1608A	10	8,000 C.T.	Push-Pull (2 Tubes)	6AQ5, 6V6, 6BQ5, EL84, SV83
1609A	10	10,000 C.T.	Push-Pull (2 Tubes)	6AQ5, 6V6, 6BQ5, EL84, SV83
1615A	15	5,000 C.T.	Push-Pull (2 Tubes)	2A3, 6A3, 6AQ5, 6B4G, 6L6, 6V6
1650E	15	8,000 C.T.	Push-Pull (2 Tubes)	6AQ5, 6V6, 6BQ5, EL84, SV83
1620A	20	6,600 C.T.	Push-Pull (2 Tubes)	6AQ5, 6L6, 6V6
1650FA	25	7,600 C.T.	Push-Pull (2 Tubes)	6L6GC, 6V6, 807, 5881, EL34
1645A	30	5,000 C.T.	Push-Pull (2 Tubes)	6L6GC, 6V6, 807, 5881, EL34
1650G	35	6,600 C.T.	Push-Pull (2 Tubes)	6L6GC, 807, 5881, EL34
1650HA	40	6,600 C.T.	Push-Pull (2 Tubes)	6L6GC, 807, 5881, EL34
1650KA	50	3,400 C.T.	Push-Pull Par. (4 Tubes)	6L6GC, 807, 5881, EL34, 6146B, 6550B
1650NA	60	4,300 C.T.	Push-Pull Par. (2 or 4 Tubes)	6L6GC, 807, 5881, EL34, 6146B, 6550B, KT88
1650PA	60	6,600 C.T.	Push-Pull (2 Tubes)	6L6GC, 807, 5881, EL34, 6146B, 6550B, KT88
1650RA	100	5,000 C.T.	Push-Pull Par. (2 or 4 Tubes)	807, 5881, EL34, 6146B, 6550B, KT88
1650TA	120	1,900 C.T.	Push-Pull Par. (4 or 6 Tubes)	6L6GC, 5881, EL34, 6550B, KT88
1650WA	280	1,900 C.T.	Push-Pull Par. (6 or 8 Tubes)	6L6GC, 5881, EL34, 6550B, KT88

Note: The above examples of possible combinations are to help you narrow down the choices of transformers for your favorite tube types. How you operate the tubes (push-pull, push-pull parallel, ultra-linear, class, B+, bias, operating points, etc.) will change optimum plate to plate load impedance. Only a few of the most popular tubes are shown. As more tubes become available we will add them to the list. A tube manual or tube manufacturer's technical data sheets should be consulted first, before making a decision on a proper output transformer.

Schematic All Parts Except 1645A, 1650E & 1650G

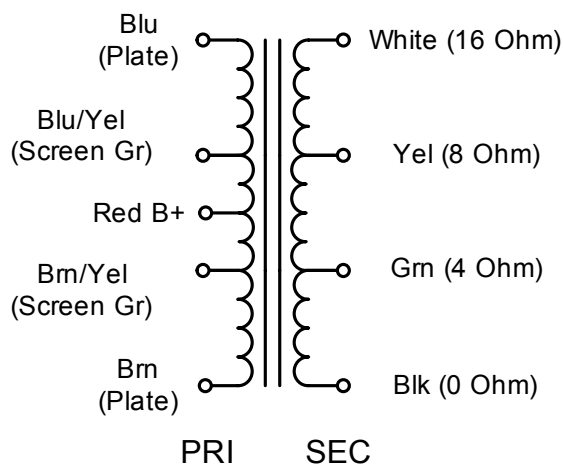

Schematic 1645A Only

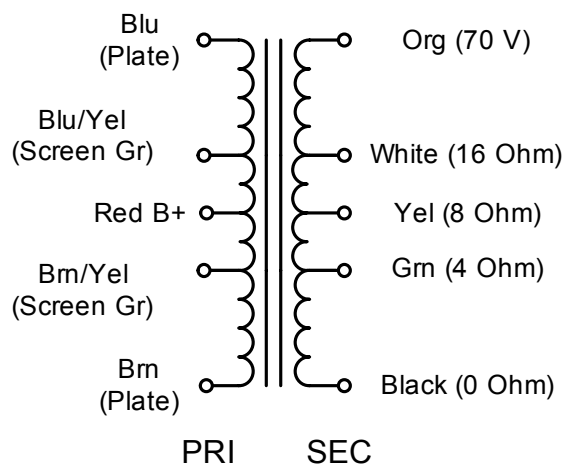

Tube Audio

Schematic - 1650E Only

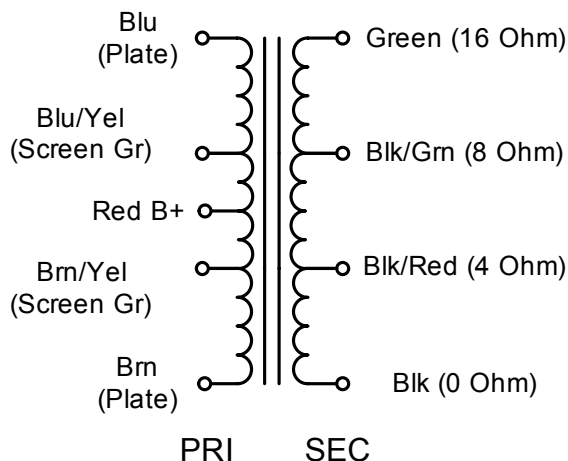

Schematic - 1650G Only

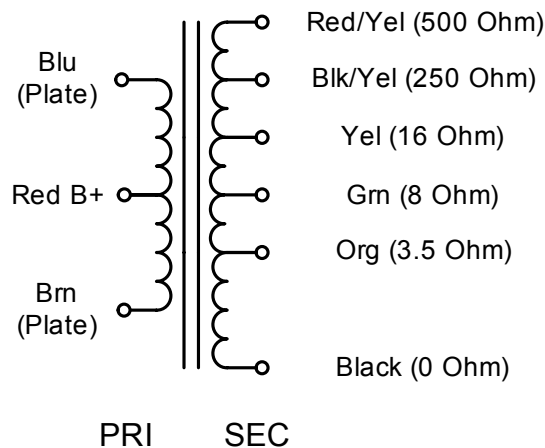

EUROPE

Basingstoke, UK 01256 812812

AUSTRALIA

Queenstown, Australia 61-8-8240-2244

www.hammondmfg.com



CANADA

Guelph, Ontario (519) 822-2960
St. Laurent, Quebec (514) 343-9010

USA

Cheektowaga, NY (716) 630-7030



Mouser Electronics

Authorized Distributor

Click to View Pricing, Inventory, Delivery & Lifecycle Information:

[Hammond:](#)

[1608](#) [1620](#) [1645](#) [1609](#) [1615](#) [1650F](#) [1650P](#) [1650T](#) [1650N](#) [1650R](#) [1650H](#) [1650K](#) [1650W](#) [1650G](#)