

THE INFORMATION CONTAINED IN THIS DRAWING IS THE SOLE PROPERTY OF L-COM, INC. ANY REPRODUCTION IN PART OR WHOLE WITHOUT THE WRITTEN PERMISSION OF L-COM, INC. IS PROHIBITED.

REVISIONS			
REV	DESCRIPTION	DATE	APPROVED
E	ECN 7231: REVISED DESCRIPTION FOR "HOOD", NEW FORMAT, ROHS NOTE	1/9/13	D.FRISIELLO

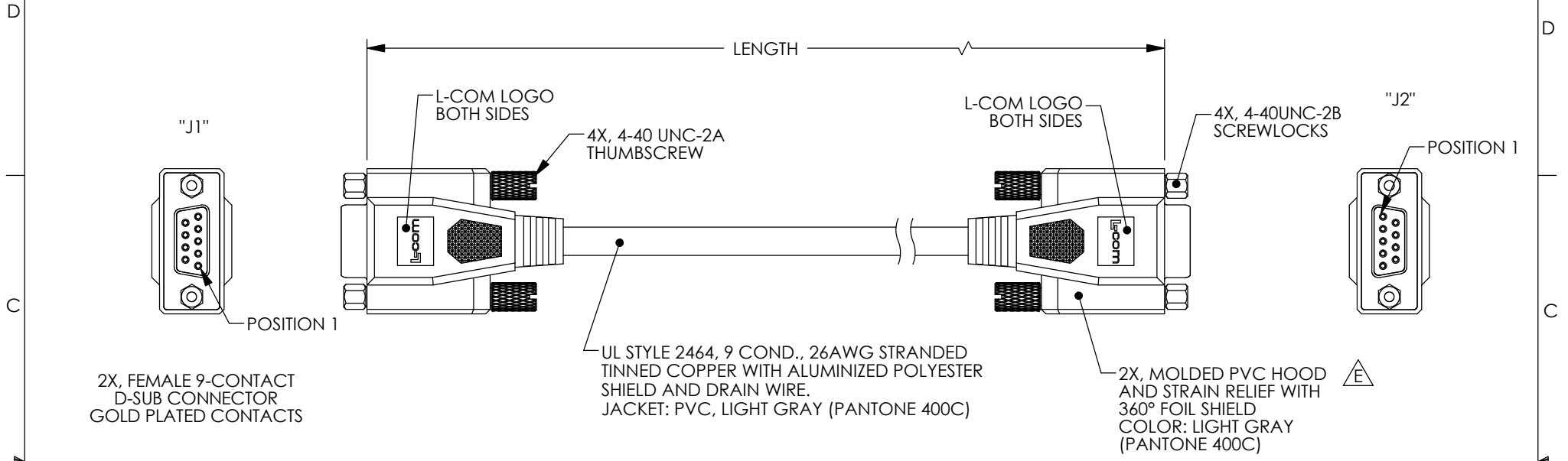

WIRING MAP		
"J1"	WIRE COLOR	"J2"
1	BLACK	1
2	GRAY	3
3	RED	2
4	GREEN	4
5	BROWN	5
6	BLUE	6
7	ORANGE	7
8	YELLOW	8
9	PURPLE	9
SHELL	DRAIN WIRE	SHELL

MODEL NUMBER	LENGTH	
	FEET	METERS
CSNULL9FF-5	5.0	1.52
CSNULL9FF-10	10.0	3.05
CSNULL9FF-25	25.0	7.62

- NOTES:**
1. CABLE ASSEMBLY SHALL BE TESTED FOR CONTINUITY.
  2. CABLE ASSEMBLY SHALL BE INDIVIDUALLY PACKAGED IN ACCORDANCE WITH L-COM SPECIFICATION PS-0031.

**REGULATORY COMPLIANCE:**  
CE2011/65/EU (RoHS DIRECTIVE)



UNLESS OTHERWISE SPECIFIED, DIMENSIONS ARE IN INCHES [mm] OVERALL CABLE LENGTH TOLERANCE: ≤12 [305] = +1 [25] / -0 >12 [305] ≤60 [1524] = +2 [51] / -0 >60 [1524] ≤120 [3048] = +4 [102] / -0 >120 [3048] ≤300 [7620] = +6 [152] / -0 >300 [7620] = +5% / -0%	APPROVALS	DATE		45 BEECHWOOD DRIVE NORTH ANDOVER, MA 01845
	DRAWN BY TJC	6/7/01		CATEGORY <b>D-SUBMINIATURE</b>
ALL OTHER DIMENSIONAL TOLERANCES: .X = ±.2 [5.08] .XX = ±.02 [1.51] .XXX = ±.005 [1.13]	CHECKED BY DFP	7/18/01	PRODUCT DESCRIPTION <b>CABLE, DB9F/DB9F NULL MODEM</b>	
	APPROVED BY CM	7/19/01		
PROJECTION 	CONFIGURATION DETAILS OF UNDIMENSIONED FEATURES MAY VARY		SIZE <b>A</b>	FSCM NO. <b>43321</b>
	COLOR VARIATIONS MAY OCCUR		DWG. NO. <b>CSNULL9FF</b>	REV. <b>E</b>
	CSNULL-FS01		SCALE: NONE	CAD FILE: CSNULL9FF.SLDDRW
			SHEET 1 OF 1	

# Mouser Electronics

Authorized Distributor

Click to View Pricing, Inventory, Delivery & Lifecycle Information:

[infinite Electronics:](#)

[CSNULL9FF-10](#) [CSNULL9FF-25](#) [CSNULL9FF-5](#)