



# **VINCULUM**

**BINDING USB TECHNOLOGIES**

**Future Technology Devices International Ltd.**

**VDIP2**

**Vinculum VNC1L Module**

**Datasheet**

**Document Reference No.: FT\_000017**

**Version 1.0**

**Issue Date: 2010-03-08**

**Future Technology Devices International Ltd (FTDI)**

**Unit 1, 2 Seaward Place, Centurion Business Park, Glasgow, G41 1HH, United Kingdom**

**Tel.: +44 (0) 141 429 2777 Fax: + 44 (0) 141 429 2758**

**E-Mail (Support): [support1@ftdichip.com](mailto:support1@ftdichip.com)**

**Web: <http://www.vinculum.com>**

Neither the whole nor any part of the information contained in, or the product described in this manual, may be adapted or reproduced in any material or electronic form without the prior written consent of the copyright holder. This product and its documentation are supplied on an as-is basis and no warranty as to their suitability for any particular purpose is either made or implied. Future Technology Devices International Ltd will not accept any claim for damages howsoever arising as a result of use or failure of this product. Your statutory rights are not affected. This product or any variant of it is not intended for use in any medical appliance, device or system in which the failure of the product might reasonably be expected to result in personal injury. This document provides preliminary information that may be subject to change without notice. No freedom to use patents or other intellectual property rights is implied by the publication of this document. Future Technology Devices International Ltd, Unit 1, 2 Seaward Place, Centurion Business Park, Glasgow, G41 1HH, United Kingdom. Scotland Registered Number: SC136640

**Copyright © 2010 Future Technology Devices International Limited**

## 1 Introduction

The VDIP2 module is an MCU to embedded USB host controller development module for the VNC1L I.C. device. The VDIP2 is supplied on a PCB designed to fit into a 40 pin DIP socket, and provides access to the UART, parallel FIFO, and SPI interface pins on the VNC1L device, via its AD and AC bus pins. All other Vinculum I/O pins are also accessible. Not only is it ideal for developing and rapid prototyping of VNC1L designs, but also an attractive quantity discount structure makes this module suitable for incorporation into low and medium volume finished product designs.

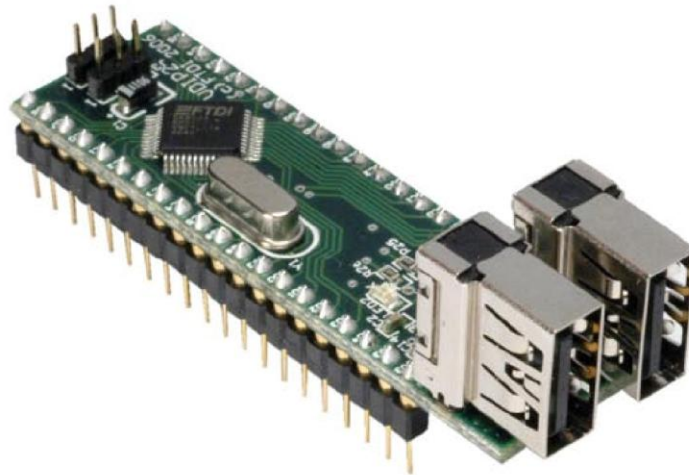

**Figure 1.1- VDIP2**

The Vinculum VNC1L is the first of FTDI's Vinculum family of Embedded USB host controller integrated circuit devices. Not only is it able to handle the USB Host Interface, and data transfer functions but owing to the inbuilt MCU and embedded Flash memory, Vinculum can encapsulate the USB device classes as well. When interfacing to mass storage devices such as USB Flash drives, Vinculum also transparently handles the FAT File structure communicating via UART, SPI or parallel FIFO interfaces via a simple to implement command set. Vinculum provides a new cost effective solution for providing USB Host capability into products that previously did not have the hardware resources available. The VNC1L is available in Pb-free (RoHS compliant) compact 48-Lead LQFP package.

## Table of Contents

<b>1</b>	<b>Introduction .....</b>	<b>1</b>
<b>2</b>	<b>Features .....</b>	<b>3</b>
<b>3</b>	<b>Pin Out and Signal Description .....</b>	<b>4</b>
<b>3.1</b>	<b>Module Pin Out.....</b>	<b>4</b>
<b>3.2</b>	<b>Pin Signal Description .....</b>	<b>5</b>
<b>3.3</b>	<b>I/O Configuration Using The Jumper Pin Header .....</b>	<b>7</b>
<b>3.4</b>	<b>Default Interface I/O Pin Configuration.....</b>	<b>8</b>
<b>3.5</b>	<b>Signal Descriptions - UART Interface .....</b>	<b>9</b>
<b>3.6</b>	<b>Signal Descriptions – Serial Peripheral Interface (SPI) .....</b>	<b>10</b>
3.6.1	SPI Slave Data Read Cycle .....	10
3.6.2	SPI Slave Data Write Cycle .....	11
	SPI Slave Data Timing Diagrams .....	12
3.6.3	12	
<b>3.7</b>	<b>Signal Descriptions - Parallel FIFO Interface .....</b>	<b>13</b>
3.7.1	Timing Diagram – Parallel FIFO Read Transaction .....	14
3.7.2	Timing Diagram - Parallel FIFO Write Transaction .....	15
<b>4</b>	<b>Firmware.....</b>	<b>16</b>
4.1.1	Firmware Support.....	16
4.1.2	Firmware Upgrades.....	16
<b>5</b>	<b>Mechanical Dimensions .....</b>	<b>17</b>
<b>6</b>	<b>Schematic Diagram .....</b>	<b>18</b>
<b>7</b>	<b>Contact Information .....</b>	<b>19</b>
	<b>Appendix A – References.....</b>	<b>20</b>
	<b>Appendix B – List of Figures and Tables .....</b>	<b>21</b>
	<b>List of Figures .....</b>	<b>21</b>
	<b>List of Tables.....</b>	<b>21</b>
	<b>Appendix C – Revision History.....</b>	<b>22</b>

---

## 2 Features

The VDIP2 has the following features:

- Uses FTDI's VNC1L embedded dual USB host controller IC device
- Two vertically mounted USB 'A' type USB socket to interface with USB peripheral devices
- Jumper selectable UART, parallel FIFO or SPI MCU interfaces
- Single 5V supply input from USB connection (no external supply necessary)
- Auxiliary 3.3 V / 200 mA power output to external logic.
- Program or update firmware via USB Flash disk or via UART/Parallel FIFO/SPI interface
- Power and traffic indicator LED's
- VNC1L firmware programming control pins PROG# and RESET# brought out onto jumper interface
- VDIP2 is a Pb-free, RoHS complaint development module.
- Schematics, and firmware files available for download from the [Vinculum website](#)

### 3 Pin Out and Signal Description

#### 3.1 Module Pin Out

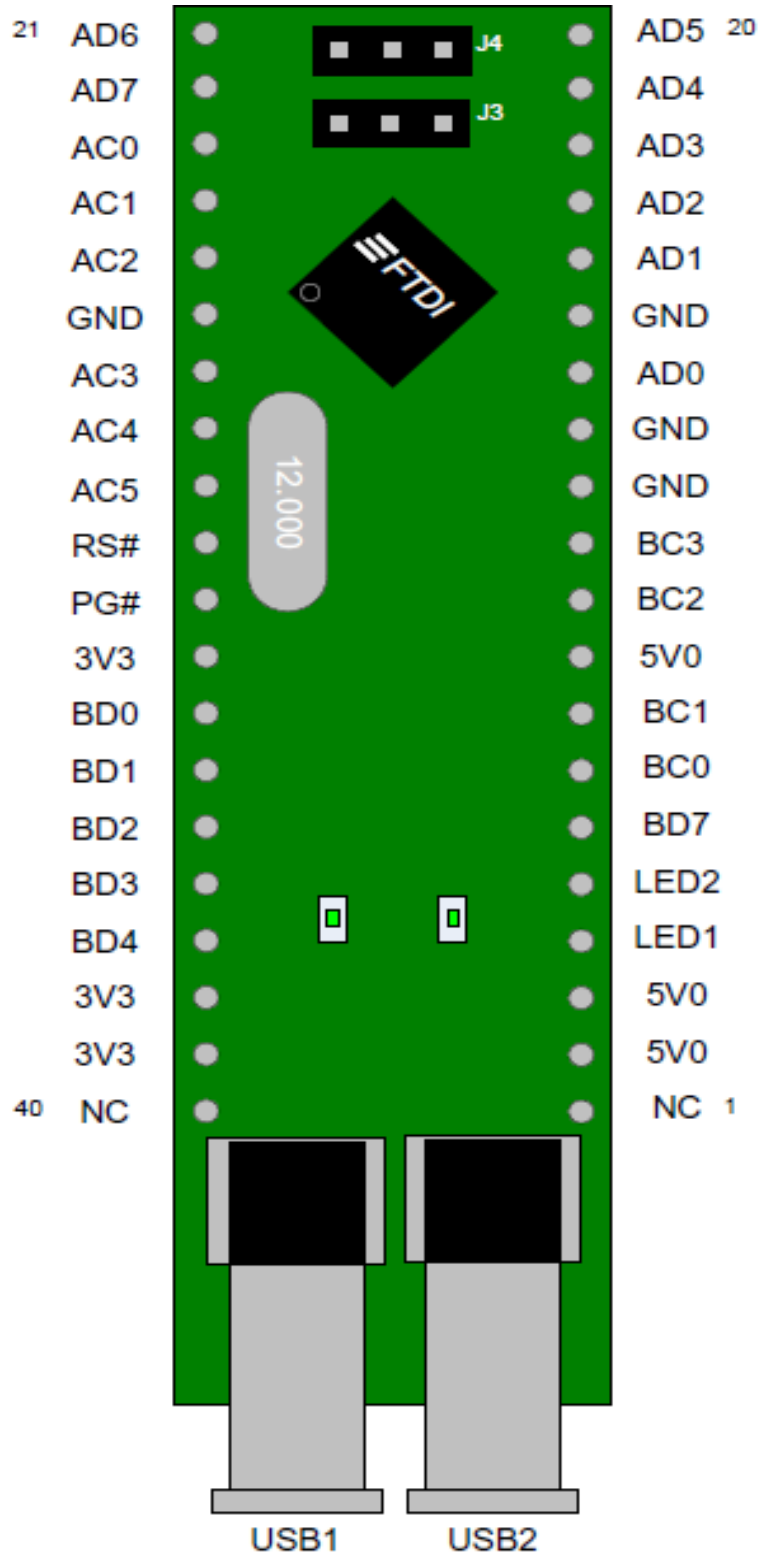

Figure 3.1 – VDIP2 Module Pin Out (Top View)

### 3.2 Pin Signal Description

Pin No.	Name	Pin Name on PCB	Type	Description
1	NC			Not connected
2	5V0	5V0	PWR Input	5.0 V module supply pin. This pin provides the 5.0V output on the USB 'A' type socket, and also the 3.3V supply to VNCL2, via an on-board 3.3 V L.D.O.
3	5V0	5V0	PWR Input	5.0 V module supply pin. This pin provides the 5.0V output on the USB 'A' type socket, and also the 3.3V supply to VNCL2, via an on-board 3.3 V L.D.O.
4	LED1	LD1	Output	USB port 1 traffic activity indicator LED. This pin is hard wired to a green LED on board the PCB. It is also brought out onto this pin which allows for the possibility of bring- ing out an additional LED traffic indicator out of the VDIP2 board. For example, if the VDIP2 USB connector is brought out onto an instrument front panel, an activity LED could be mounted along side it.
5	LED2	LD2	Output	USB port 2 traffic activity indicator LED. This pin is hard wired to a green LED on board the PCB. It is also brought out onto this pin which allows for the possibility of bring- ing out an additional LED traffic indicator out of the VDIP2 board. For example, if the VDIP2 USB connector is brought out onto an instrument front panel, an activity LED could be mounted along side it.
6	BDBUS7	BD7	I/O	5V safe bidirectional data / control bus, BD bit 7
7	BCBUS0	BC0	I/O	5V safe bidirectional data / control bus, BC bit 0
8	BCBUS1	BC1	I/O	5V safe bidirectional data / control bus, BC bit 1
9	5V0	5V0	PWR Input	5.0 V module supply pin. This pin provides the 5.0V output on the USB 'A' type socket, and also the 3.3V supply to VNC1L, via an on-board 3.3 V L.D.O.
10	BCBUS2	BC2	I/O	5V safe bidirectional data / control bus, BC bit 2
11	BCBUS3	BC3	I/O	5V safe bidirectional data / control bus, BC bit 3
12	GND	GND	PWR	Module ground supply pin
13	GND	GND	PWR	Module ground supply pin
14	ADBUS0	AD0	I/O	5V safe bidirectional data / control bus, AD bit 0
15	GND	GND	PWR	Module ground supply pin
16	ADBUS1	AD1	I/O	5V safe bidirectional data / control bus, AD bit 1
17	ADBUS2	AD2	I/O	5V safe bidirectional data / control bus, AD bit 2
18	ADBUS3	AD3	I/O	5V safe bidirectional data / control bus, AD bit 3
19	ADBUS4	AD4	I/O	5V safe bidirectional data / control bus, AD bit 4
20	ADBUS5	AD5	I/O	5V safe bidirectional data / control bus, AD bit 5
21	ADBUS6	AD6	I/O	5V safe bidirectional data / control bus, AD bit 6
22	ADBUS7	AD7	I/O	5V safe bidirectional data / control bus, AD bit 7
23	ACBUS0	AC0	I/O	5V safe bidirectional data / control bus, AC bit 0
24	ACBUS1	AC1	I/O	5V safe bidirectional data / control bus, AC bit 1
26	GND	GND	PWR	Module ground supply pin
27	ACBUS3	AC3	I/O	5V safe bidirectional data / control bus, AC bit 3
28	ACBUS4	AC4	I/O	5V safe bidirectional data / control bus, AC bit 4
29	ACBUS5	AC5	I/O	5V safe bidirectional data / control bus, AC bit 5
30	RESET#	RS#	Input	Can be used by an external device to reset the VNC1L. This pin can be used in combi- nation with PROG# and the UART / parallel FIFO / SPI interface to program firmware into the
31	PROG#	PG#	Input	This pin is used in combination with the RESET# pin and the UART / parallel FIFO /
32	3V3	3V3	PWR Output	3.3V output from VDIP2's on board 3.3V L.D.O.

Table 3.1 - Pin Signal Descriptions

<b>Pin No.</b>	<b>Name</b>	<b>Pin Name on PCB</b>	<b>Type</b>	<b>Description</b>
33	BDBUS0	BD0	I/O	5V safe bidirectional data / control bus, BD bit 0
34	BDBUS1	BD1	I/O	5V safe bidirectional data / control bus, BD bit 1
35	BDBUS2	BD2	I/O	5V safe bidirectional data / control bus, BD bit 2
36	BDBUS3	BD3	I/O	5V safe bidirectional data / control bus, BD bit 3
37	BDBUS4	BD4	I/O	5V safe bidirectional data / control bus, BD bit 4
38	3V3	3V3	PWR Output	3.3V output from VDIP2's on board 3.3V L.D.O.
39	3V3	3V3	PWR Output	3.3V output from VDIP2's on board 3.3V L.D.O.
40	NC			No Connect

**Table 3.1 - Pin Signal Descriptions**

### 3.3 I/O Configuration Using The Jumper Pin Header

Two three way jumper pin headers are provided to allow for simple configuration of the I/O on data and control bus pins of the VDIP2. This is done by a combination of pulling up or pulling down the VNC1L ACBUS5 (pin 46) and ACBUS6 (pin 47). The relevant portion of the VDIP2 module schematic is shown in **Figure 3.2**

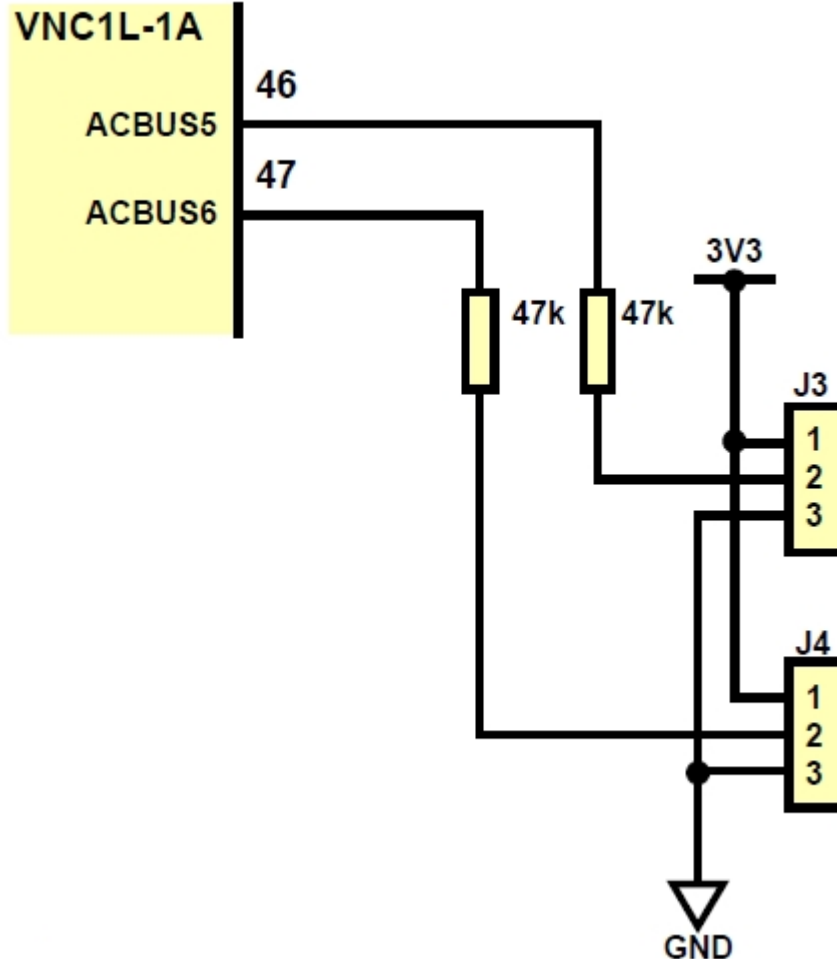

**Figure 3.2 – VDIP2 On-Board Jumper Pin Configuration.**

<i>ACBUS6</i> (VNC1L pin 47)	<i>ACBUS5</i> (VNC1L pin 46)	<i>I/O Mode</i>
Pull-Up	Pull-Up	Serial UART
Pull-Up	Pull-Down	SPI
Pull-Down	Pull-Up	Parallel FIFO
Pull-Down	Pull-Down	Serial UART

**Table 3.2 – VDIP2 Port Selection Jumper Pins**



### 3.4 Default Interface I/O Pin Configuration

The VNC1L device is pre-programmed with default settings for the I/O pins however they can be easily changed to suit a designers needs. The default interface I/O pin configuration of the VNC1L device are shown in **Table 3.3**

Pin No.	Name	Pin Name on PCB	Type	Description	Data and Control Bus Configuration Options			
					UART Interface	Parallel FIFO Interface	SPI Slave Interface	I/O Port
14	ADBUS0	AD0	I/O	5V safe bidirectional data / control bus, AD bit 0	TXD	D0	SCLK	PortAD0
16	ADBUS1	AD1	I/O	5V safe bidirectional data / control bus, AD bit 1	RXD	D1	SDI	PortAD1
17	ADBUS2	AD2	I/O	5V safe bidirectional data / control bus, AD bit 2	RTS#	D2	SDO	PortAD2
18	ADBUS3	AD3	I/O	5V safe bidirectional data / control bus, AD bit 3	CTS#	D3	CS	PortAD3
19	ADBUS4	AD4	I/O	5V safe bidirectional data / control bus, AD bit 4	DTR#	D4	NA	PortAD4
20	ADBUS5	AD5	I/O	5V safe bidirectional data / control bus, AD bit 5	DSR#	D5	NA	PortAD5
21	ADBUS6	AD6	I/O	5V safe bidirectional data / control bus, AD bit 6	DCD#	D6	NA	PortAD6
22	ADBUS7	AD7	I/O	5V safe bidirectional data / control bus, AD bit 7	RI#	D7	NA	PortAD7
23	ACBUS0	AC0	I/O	5V safe bidirectional data / control bus, AC bit 0	TXDEN#	RXF#	NA	PortAC0
24	ACBUS1	AC1	I/O	5V safe bidirectional data / control bus, AC bit 1	NA	TXE#	NA	PortAC1
25	ACBUS2	AC2	I/O	5V safe bidirectional data / control bus, AC bit 2	NA	RD#	NA	PortAC2
27	ACBUS3	AC3	I/O	5V safe bidirectional data / control bus, AC bit 3	NA	WR	NA	PortAC3
28	ACBUS4	AC4	I/O	5V safe bidirectional data / control bus, AC bit 4	NA	NA	NA	PortAC4

**Table 3.3 - Default Interface I/O Pin Configuration**

### 3.5 Signal Descriptions - UART Interface

The UART interface I/O pin description of the VNC1L device are shown in **Table 3.4**

<i>Pin No.</i>	<i>Name</i>	<i>Type</i>	<i>Description</i>
14	TXD	Output	Transmit asynchronous data output
16	RXD	Input	Receive asynchronous data input
17	RTS#	Output	Request To Send Control Output / Handshake signal
18	CTS#	Input	Clear To Send Control Input / Handshake signal
19	DTR#	Output	Data Terminal Ready Control Output / Handshake signal
20	DSR#	Input	Data Set Ready Control Input / Handshake signal
21	DCD#	Input	Data Carrier Detect Control Input
22	RI#	Input	Ring Indicator Control Input. When the Remote Wake Up option is enabled in the EEPROM, taking RI# low can be used to resume the PC USB Host controller from suspend
23	TXDEN#	Input	Enable Transmit Data for RS485 designs

**Table 3.4 - Default I/O Pin Configuration – UART Interface**

### 3.6 Signal Descriptions – Serial Peripheral Interface (SPI)

The SPI I/O pin description of the VNC1L device are shown in **Table 3.5**

Pins No	Name	Type	Description
14	SCLK	Input	SPI Clock input, 12MHz maximum.
16	SDI	Input	SPI Serial Data Input
17	SDO	Output	SPI Serial Data Output
18	CS	Input	SPI Chip Select Input

**Table 3.5 - Data and Control Bus Signal Mode Options – SPI Slave Interface**

#### 3.6.1 SPI Slave Data Read Cycle

When in SPI mode, the timing of a read operation is shown in Figure 3.3

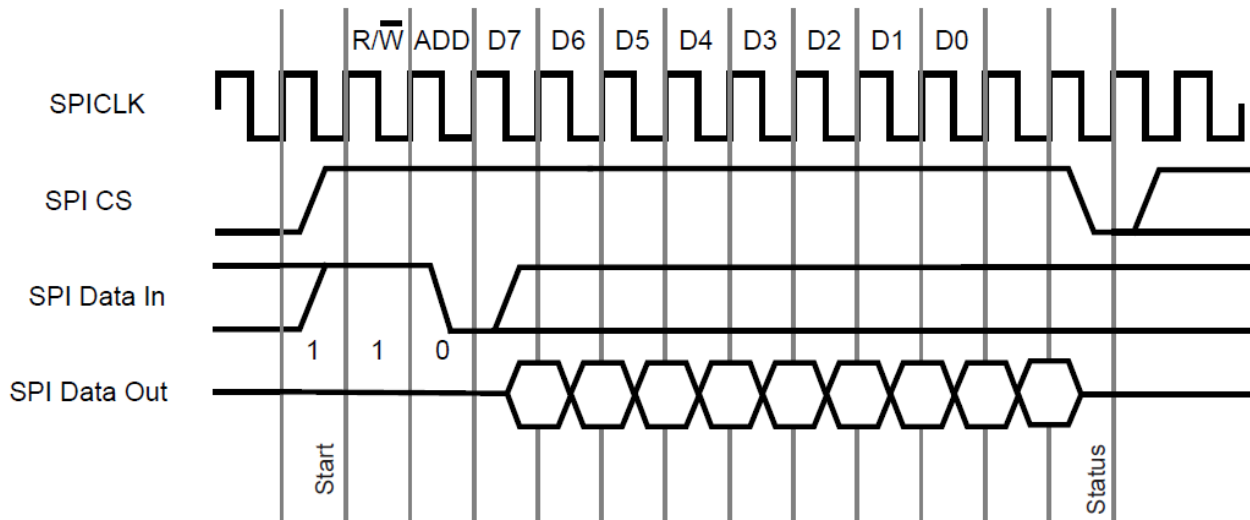
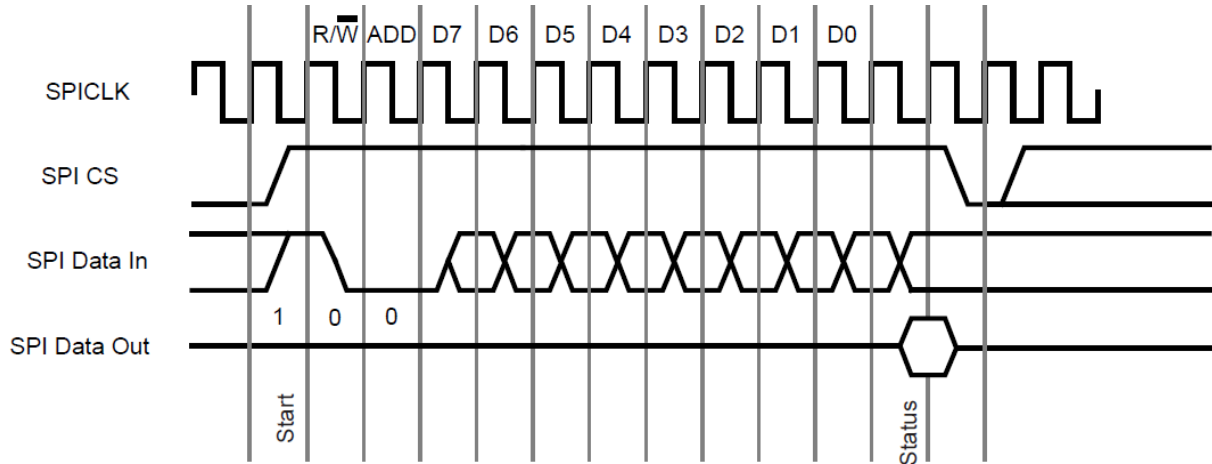

**Figure 3.3 – SPI Slave Data Read Cycle.**

From Start - SPI CS must be held high for the entire read cycle, and must be taken low for at least one clock period after the read is completed. The first bit on SPI Data In is the R/W bit - inputting a '1' here allows data to be read from the chip. The next bit is the address bit, ADD, which is used to indicate whether the data register ('0') or the status register ('1') is read from. During the SPI read cycle a byte of data will start being output on SPI Data Out on the next clock cycle after the address bit, MSB. After the first time the data has been clocked out of the chip, the status of SPI Data Out should be checked to see if the data read is new data. A '0' level here on SPI Data Out means that the data read is new data. A '1' indicates that the data read is old data, and the read cycle should be repeated to get new data. Remember that CS must be held low for at least one clock period before being taken high again to continue with the next read or write cycle.

### 3.6.2 SPI Slave Data Write Cycle

When in SPI mode, the timing of a write operation is shown in



**Figure 3.4 – SPI Slave Data Write Cycle.**

From Start - SPI CS must be held high for the entire write cycle, and must be taken low for at least one clock period after the write is completed. The first bit on SPI Data In is the R/W bit - inputting a '0' here allows data to be written to the chip. The next bit is the address bit, ADD, which is used to indicate whether the data register ('0') or the status register ('1') is written to. During the SPI write cycle a byte of data can be input to SPI Data In on the next clock cycle after the address bit, MSB. After first, the data has been clocked in to the chip, the status of SPI Data Out should be checked to see if the data read was accepted. A '0' level on SPI Data Out means that the data write was accepted. A '1' indicates that the internal buffer is full, and the write should be repeated. Remember that CS must be held low for at least one clock period before being taken high again to continue with the next read or write cycle.

### 3.6.3 SPI Slave Data Timing Diagrams

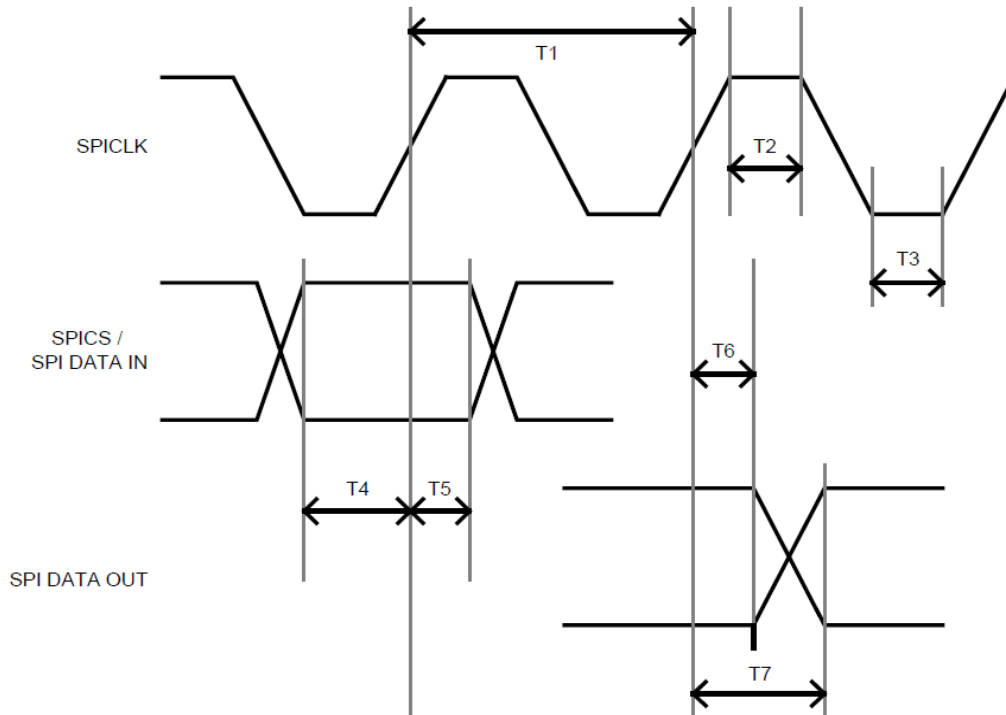

Figure 3.5 – SPI Slave Data Timing Diagrams.

Time	Description	Min	Typical	Max	Unit
T1	SPICLK Period	83	-	-	ns
T2	SPICLK High	20	-	-	ns
T3	SPICLK Low	20	-	-	ns
T4	Input Setup Time	10	-	-	ns
T5	Input Hold Time	10	-	-	ns
T6	Output Hold Time	2	-	-	ns
T7	Output Valid Time	-	-	20	ns

Table 3.6 - SPI Slave Data Timing

Time	Description
0	RXF#
1	TXE#
2	-
3	-
4	RXF IRQEn
5	TXE IRQEn
6	-
7	-

Table 3.7 - SPI Slave Status Register (ADD='1')

### 3.7 Signal Descriptions - Parallel FIFO Interface

The Parallel FIFO interface I/O pin description of the VNC1L device is shown in **Table 3.8**

<i>Pin No.</i>	<i>Name</i>	<i>Type</i>	<i>Description</i>
14	D0	I/O	FIFO Data Bus Bit 0
16	D1	I/O	FIFO Data Bus Bit 1
17	D2	I/O	FIFO Data Bus Bit 2
18	D3	I/O	FIFO Data Bus Bit 3
19	D4	I/O	FIFO Data Bus Bit 4
20	D5	I/O	FIFO Data Bus Bit 5
21	D6	I/O	FIFO Data Bus Bit 6
22	D7	I/O	FIFO Data Bus Bit 7
23	RXF#	OUTPUT	When high, do not read data from the FIFO. When low, there is data available in the FIFO which can be read by strobing RD# low, then high again.
24	TXE#	OUTPUT	When high, do not write data into the FIFO. When low, data can be written into the FIFO by strobing WR high, then low.
25	RD#	INPUT	Enables the current FIFO data byte on D0...D7 when low. Fetches the next FIFO data byte (if available) from the receive FIFO buffer when RD# goes from high to low
27	WR	INPUT	Writes the data byte on the D0...D7 pins into the transmit FIFO buffer when WR goes from high to low.

**Table 3.8 - Default Interface I/O Pin Configuration Option – Parallel FIFO Interface**

### 3.7.1 Timing Diagram – Parallel FIFO Read Transaction

When in parallel FIFO interface mode, the timing of a read is shown in **Figure 3.6** and **Table 3.9**

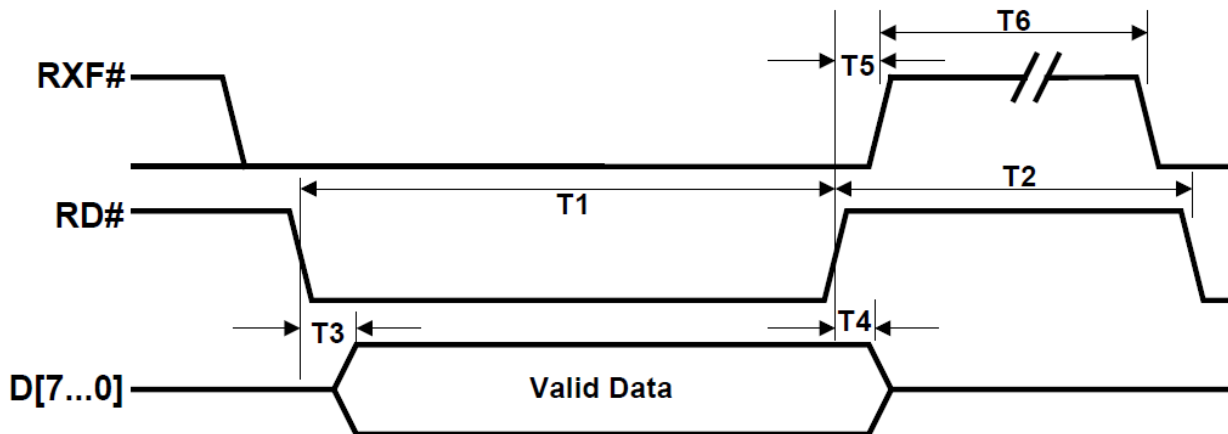

Figure 3.6 - FIFO Read Cycle.

Time	Description	Min	Max	Unit
T1	RD# Active Pulse Width	50	-	ns
T2	RD# to RD# Pre-Charge Time	50 + T6	-	ns
T3	RD# Active to Valid Data*	20	50	ns
T4	Valid Data Hold Time from RD#	0	-	ns
T5	RD# Inactive to RXF#	0	25	ns
T6	RXF# Inactive After RD# Cycle	80	-	ns

**Table 3.9 FIFO Read Cycle Timing**

\* Load = 30pF

### 3.7.2 Timing Diagram - Parallel FIFO Write Transaction

When in parallel FIFO interface mode, the timing of a write operation is shown in **Figure 3.7** and **Table 3.10**

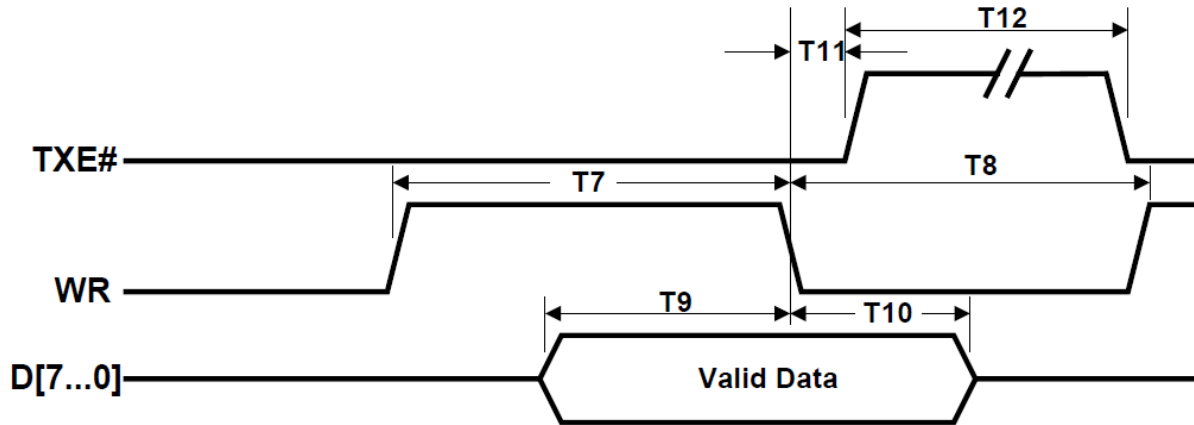

**Figure 3.7 - FIFO Write Cycle.**

<i>Time</i>	<i>Description</i>	<i>Min</i>	<i>Max</i>	<i>Unit</i>
T7	WR Active Pulse Width	50	-	ns
T8	WR to WR Pre-Charge Time	50	-	ns
T9	WR Active to Valid Data	20	-	ns
T10	Data Hold Time from WR	0	-	ns
T11	WR Inactive to TXE#	5	25	ns
T12	TXE# Inactive After WR Cycle	80	-	ns

**Table 3.10 - FIFO Write Cycle Timing**



---

## 4 Firmware

### 4.1.1 Firmware Support

There are currently 6 standard firmware versions available for VDIP2 module which can be downloaded from the [FTDI website](#).

- VDAP Firmware: USB Host for single Flash Disk and General Purpose USB peripherals. Selectable UART, FIFO or SPI interface command monitor.
- VDPS Firmware: USB Host for single Flash Disk and General Purpose USB peripherals. USB Slave port connection for connecting to host PC. Selectable UART, FIFO or SPI interface command monitor.
- VDFC Firmware: USB Host for two Flash Disks, Selectable UART, FIFO or SPI interface command monitor.
- VCDC Firmware: USB Host for automatic connection to USB Communications Class Devices. UART interface command monitor.
- VDIF Firmware: USB Host for single Flash Disk and General Purpose USB peripherals. Selectable UART, FIFO, SPI or USB interface command monitor.

### 4.1.2 Firmware Upgrades

The VDIP2 module is supplied pre-loaded with the VDAP firmware.

There are two methods of upgrading the firmware on the VDIP2. These methods are described in a Vinculum Firmware manual please refer to:-

[http://www.vinculum.com/documents/fwspecs/UM\\_VinculumFirmware\\_V205.pdf](http://www.vinculum.com/documents/fwspecs/UM_VinculumFirmware_V205.pdf)

## 5 Mechanical Dimensions

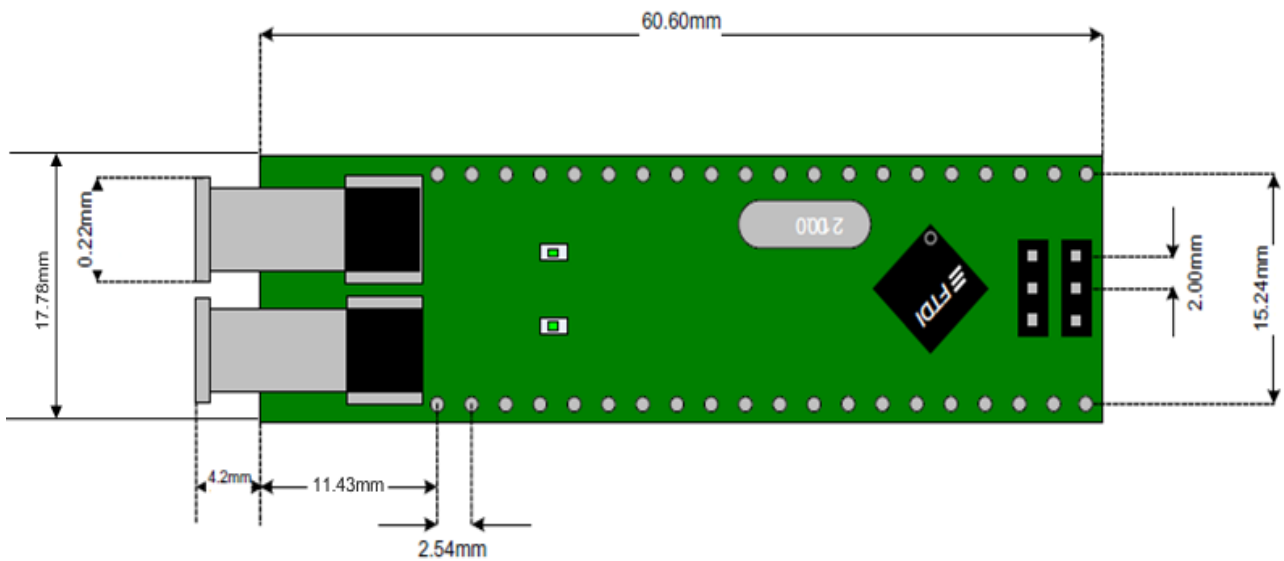

Figure 5.1 VDIP2 Dimensions (Top View)

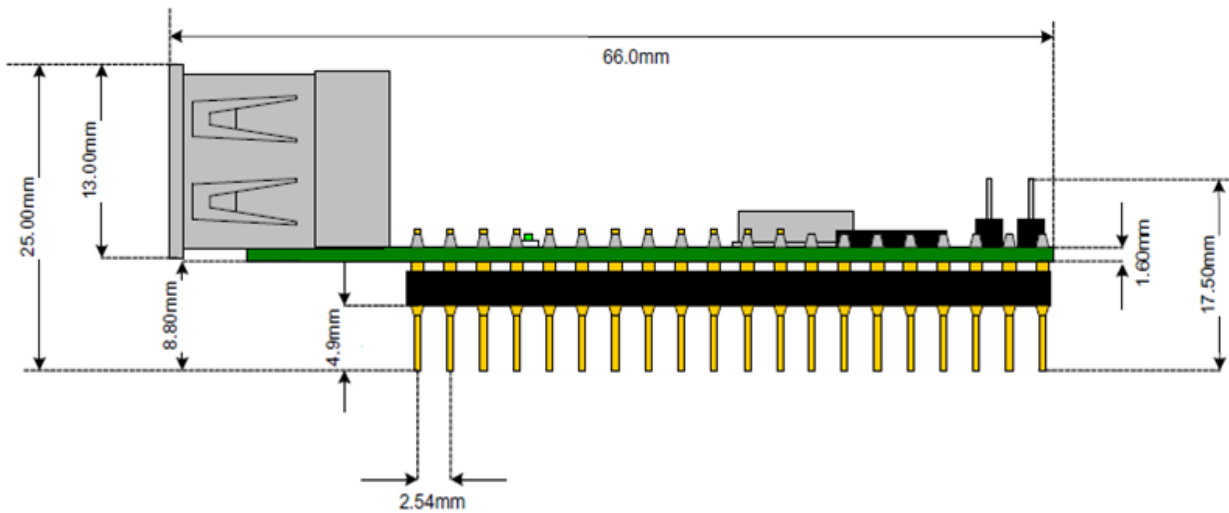

Figure 5.2 VDIP2 Dimensions (Side View)

## 6 Schematic Diagram

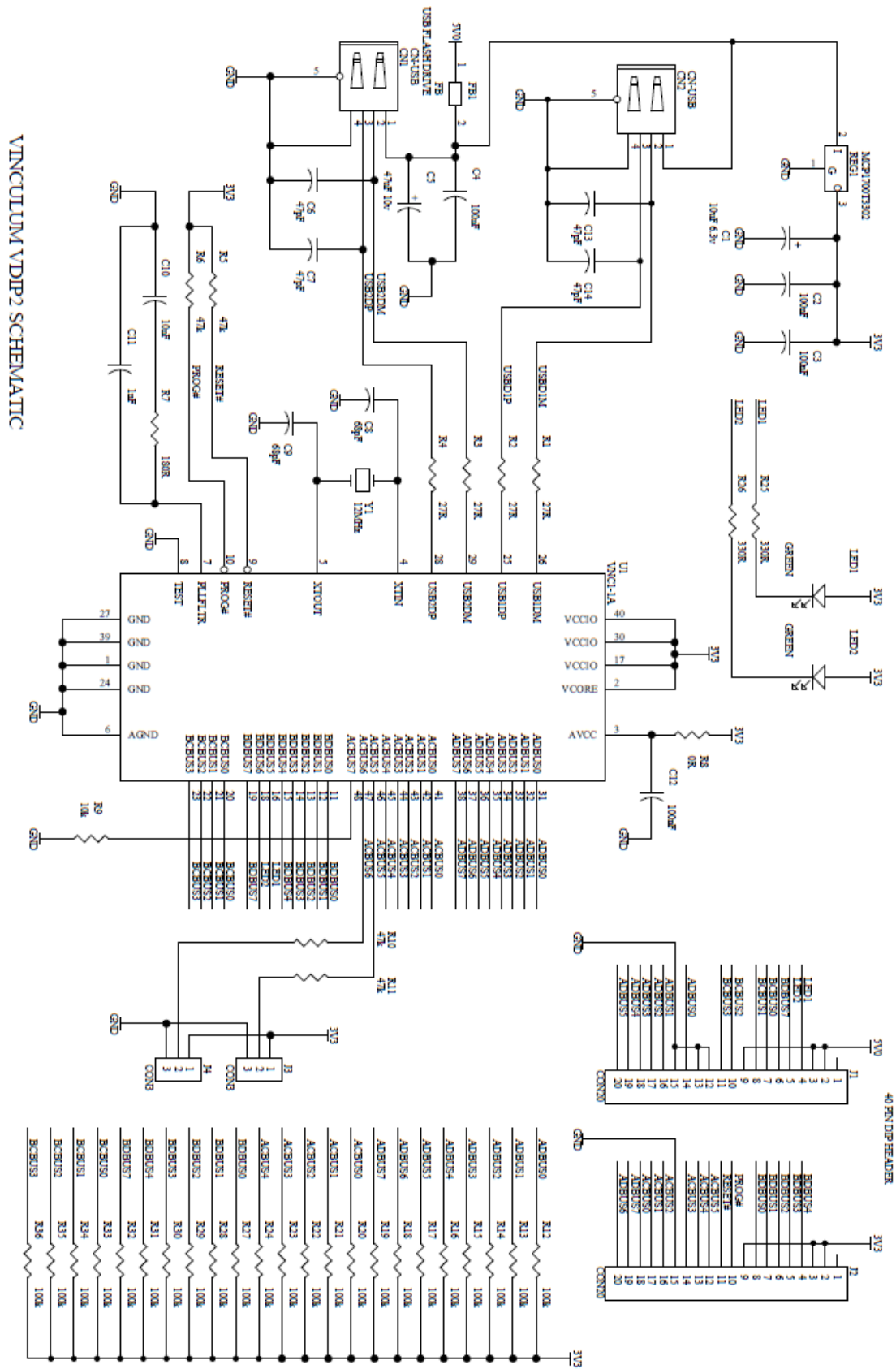

Figure 6.1 - Schematic Diagram

## 7 Contact Information

### Head Office – Glasgow, UK

Future Technology Devices International Limited  
Unit 1, 2 Seaward Place,  
Centurion Business Park  
Glasgow, G41 1HH  
United Kingdom  
Tel: +44 (0) 141 429 2777  
Fax: +44 (0) 141 429 2758

E-mail (Sales) [sales1@ftdichip.com](mailto:sales1@ftdichip.com)  
E-mail (Support) [support1@ftdichip.com](mailto:support1@ftdichip.com)  
E-mail (General Enquiries) [admin1@ftdichip.com](mailto:admin1@ftdichip.com)  
Web Site URL <http://www.ftdichip.com>  
Web Shop URL <http://www.ftdichip.com>

### Branch Office – Taipei, Taiwan

Future Technology Devices International Limited (Taiwan)  
2F, No 516, Sec. 1 NeiHu Road  
Taipei 114  
Taiwan, R.O.C.  
Tel: +886 (0) 2 8791 3570  
Fax: +886 (0) 2 8791 3576

E-mail (Sales) [tw.sales1@ftdichip.com](mailto:tw.sales1@ftdichip.com)  
E-mail (Support) [tw.support1@ftdichip.com](mailto:tw.support1@ftdichip.com)  
E-mail (General Enquiries) [tw.admin1@ftdichip.com](mailto:tw.admin1@ftdichip.com)  
Web Site URL <http://www.ftdichip.com>

### Branch Office – Hillsboro, Oregon, USA

Future Technology Devices International Limited (USA)  
7235 NW Evergreen Parkway, Suite 600  
Hillsboro, OR 97123-5803  
USA  
Tel: +1 (503) 547 0988  
Fax: +1 (503) 547 0987

E-Mail (Sales) [us.sales@ftdichip.com](mailto:us.sales@ftdichip.com)  
E-Mail (Support) [us.support@ftdichip.com](mailto:us.support@ftdichip.com)  
E-Mail (General Enquiries) [us.admin@ftdichip.com](mailto:us.admin@ftdichip.com)  
Web Site URL <http://www.ftdichip.com>

### Branch Office – Shanghai, China

Future Technology Devices International Limited (China)  
Room 408, 317 Xianxia Road,  
ChangNing District,  
ShangHai, China

Tel: +86 (21) 62351596  
Fax: +86(21) 62351595

E-Mail (Sales): [cn.sales@ftdichip.com](mailto:cn.sales@ftdichip.com)  
E-Mail (Support): [cn.support@ftdichip.com](mailto:cn.support@ftdichip.com)  
E-Mail (General Enquiries): [cn.admin1@ftdichip.com](mailto:cn.admin1@ftdichip.com)  
Web Site URL <http://www.ftdichip.com>

### Distributor and Sales Representatives

Please visit the Sales Network page of the FTDI Web site for the contact details of our distributor(s) and sales representative(s) in your country.

## Appendix A – References

[http://www.vinculum.com/documents/fwspecs/UM\\_VinculumFirmware\\_V205.pdf](http://www.vinculum.com/documents/fwspecs/UM_VinculumFirmware_V205.pdf)

## Appendix B – List of Figures and Tables

### List of Figures

Figure 1.1- VDIP2 .....	1
Figure 3.1 – VDIP2 Module Pin Out (Top View) .....	4
Figure 3.2 – VDIP2 On-Board Jumper Pin Configuration. ....	7
Figure 3.3 – SPI Slave Data Read Cycle. ....	10
Figure 3.4 – SPI Slave Data Write Cycle. ....	11
Figure 3.5 – SPI Slave Data Timing Diagrams.....	12
Figure 3.6 - FIFO Read Cycle.....	14
Figure 3.7 - FIFO Write Cycle. ....	15
Figure 5.1 VDIP2 Dimensions (Top View) .....	17
Figure 5.2 VDIP2 Dimensions (Side View) .....	17
Figure 7.1 - Schematic Diagram .....	18

### List of Tables

Table 3.1 - Pin Signal Descriptions .....	5
Table 3.2 – VDIP2 Port Selection Jumper Pins .....	7
Table 3.5 - Data and Control Bus Signal Mode Options – SPI Slave Interface.....	10
Table 3.6 - SPI Slave Data Timing .....	12
Table 3.7 - SPI Slave Status Register (ADD='1') .....	12
Table 3.8 - Default Interface I/O Pin Configuration Option – Paralle FIFO Interface .....	13
Table 3.9 FIFO Read Cycle Timing.....	14
Table 3.10 - FIFO Write Cycle Timing .....	15

---

## Appendix C – Revision History

Version 0.90	Initial Datasheet Created	March 2007
Version 0.91	Datasheet Updated table 4,5 and 8	April 2007
Version 1.0	Datasheet Updated (Reformatted)	08 March 2010
	Datasheet Updated (Mechanical Drawings)	
	Added Appendix A and B	
	Added schematic	

# Mouser Electronics

Authorized Distributor

Click to View Pricing, Inventory, Delivery & Lifecycle Information:

[FTDI:](#)

[VDIP2](#)