

**Model 73033  
MMCX PLUG R/A SEMI-RIGID, RG405**



Model 73033 MMCX PLUG R/A SEMI-RIGID, RG405

Snap-on coupling and micro-miniature size for fast connect and disconnect where space is limited

**Features**

- DC - 6 GHz bandwidth.
- 50% smaller than MCX connectors.
- Connectors allow rotation of 360° for layout flexibility.
- Non-slotted contact design for low RF leakage.
- Meets CECC 22340.
- Perfect for applications where space, weight, performance and ease of assembly are required.

**Materials**

- Body is machined brass with gold plating.
- Center contacts – Plug is gold plated Phosphor bronze and Jack is gold plated beryllium copper.
- High quality PTFE insulators.
- Crimp Ferrules are gold or nickel plated copper.

**Ordering Information**

Model: 73033  
Description: MMCX PLUG R/A SEMI-RIGID, RG405

**USA:** Sales: 800-490-2361  
Technical Support: [technicalsupport@pomonatest.com](mailto:technicalsupport@pomonatest.com)  
Fax: 425-446-5844

**Europe:** 31-(0) 40 2675 150 **International:** 425-446-5500

**Where to Buy:** [www.pomonaelectronics.com](http://www.pomonaelectronics.com)

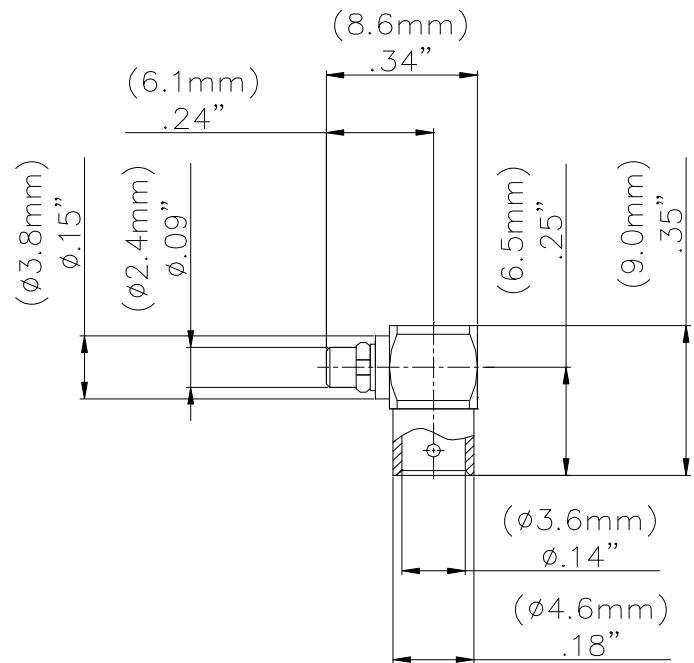

**Specifications**

Impedance	50 Ω
Frequency Range	DC - 6 GHz
Working Voltage	170 Vrms max.
Dielectric Withstanding Voltage	500 Vrms
VSWR	1.3 max
Center / Outer contact resistance	0.01 / 0.005 Ω
Number of insertions	500 cycles minimum
Insulation resistance	> 1000 MΩ
Temperature Range	-55° C to 155° C, -67° F to 311° F

All dimensions are in inches. Tolerances (except noted): .xx = ±.02" (.51 mm), .xxx = ±.005" (.127 mm). All specifications are to the latest revisions. Specifications are subject to change without notice. Registered trademarks are the property of their respective companies.  
D2003384 REV 001

**Model 73033  
MMCX PLUG R/A SEMI-RIGID, RG405**

**Cable Types and Crimp Die Information**

Connector Model #	Cable Groups	Crimp Die Cavity Size for Outer Ferrule
73033	RG405	.151 (3.8)

**Cable Assembly Instructions**

1. CUT CABLE END EVENLY AND PERPENDICULAR

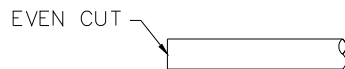

2. STRIP CABLE JACKET, BRAID, AND DIELECTRIC TO SPECIFICATION LENGTHS.

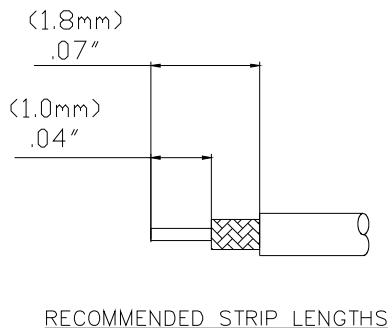

3. SLIDE CONNECTOR BODY OVER CENTER CONDUCTOR, DIELECTRIC AND CABLE JACKET.

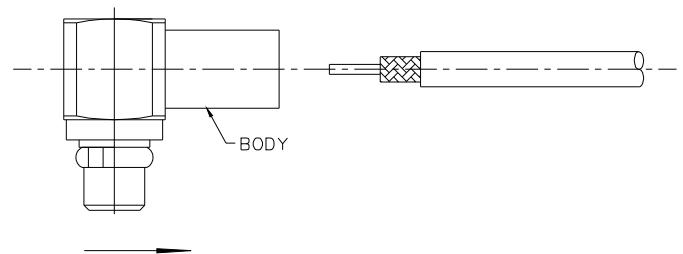

4. PRESS INSULATOR AND CAP INTO CONNECTOR BODY.

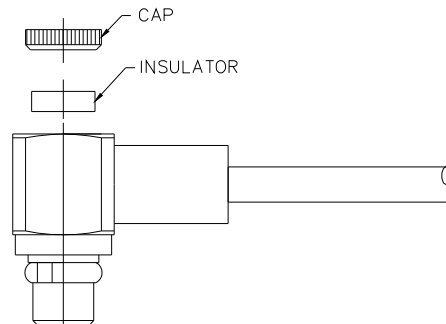

# Mouser Electronics

Authorized Distributor

Click to View Pricing, Inventory, Delivery & Lifecycle Information:

[Pomona:](#)

[73033](#)