

# EC45A 45mm Size Ring Type

Large ring, heavy torque device perfect for large ring knob design

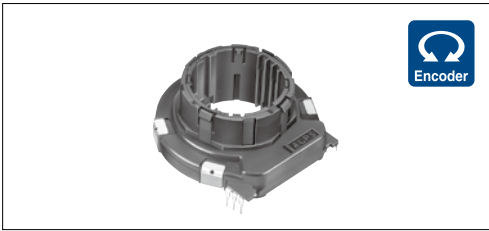

Encoders



## Typical Specifications

Items	Specifications
Rating(max.)	0.5mA 5V DC
Operating life	30,000 cycles
Operating temperature range	-40°C to +85°C

## Product Line

Output code	Positions	Rotational angle	Detent torque (mN·m)	Minimum order unit (pcs.)		Product No.
				Japan	Export	
5bit Gray code	31	240°	36±16	280	560	<b>EC45AG520402</b>

### Note

Other varieties are also available. Please inquire.

## Packing Specifications

### Tray

Number of packages (pcs.)		Export package measurements (mm)
1 case /Japan	1 case /export packing	
280	560	525×375×477

## Dimensions

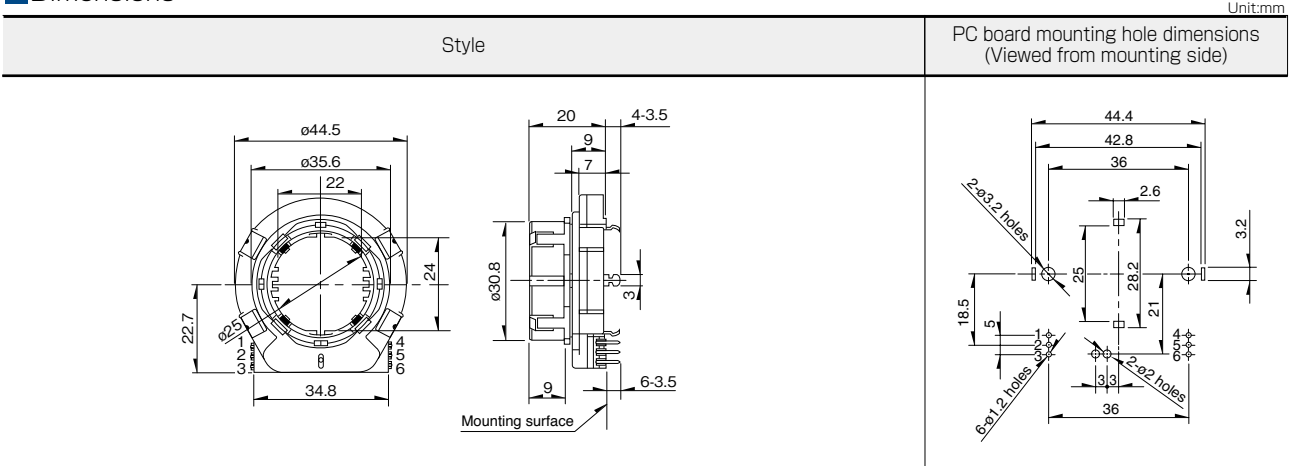









## Standard Codes (Number of Positions : 31)

Code	Terminal	Position																														
		1	2	3	4	5	6	7	8	9	10	11	12	13	14	15	16	17	18	19	20	21	22	23	24	25	26	27	28	29	30	31
Gray	4	●	●			●	●			●	●			●	●			●	●			●	●			●	●			●	●	
	2		●	●	●	●					●	●	●	●					●	●	●	●					●	●	●	●		
	3				●	●	●	●	●	●	●	●										●	●	●	●	●	●	●	●	●	●	
	5								●	●	●	●	●	●	●	●	●	●	●	●	●	●	●	●	●	●						
	6																	●	●	●	●	●	●	●	●	●	●	●	●	●	●	●

- The ● marks shows the ON position.
- The ● marks : Connections between terminals and the common terminal (terminal No. =1) are ON.

# Encoders

## List of Varieties

Type		Ring type			
		40mm size	45mm size	50mm size	60mm size
Series		<b>EC40A</b>	<b>EC45A</b>	<b>EC50A</b>	<b>EC60B</b>
Photo					
Output		Incremental (Two phase A and B)	Absolute type	Incremental (Two phase A and B)	
Shaft types		Ring type			
Number of pulse / Number of detent		15/30	31 positions	9/18	15/30
Dimensions (mm)	W	40.4	44.5	50.8	62.4
	D	43	45	50	60
	H	9		6.5	7.5
Operating temperature range		-40°C to +85°C			
Operating life		30,000 cycles		40,000 cycles	
Automotive use		●	●	●	●
Life cycle (availability)					
Electrical performance	Rating	0.5mA 5V DC		1mA 5V DC	10mA 5V DC
	Max./min. operating current (Resistive load)	—	—	—	—
	Insulation resistance	10MΩ min. 50V DC		10MΩ min. 250V DC	100MΩ min. 250V DC
	Voltage proof	50V AC for 1 minute	50V AC for 1 minute or 60V AC for 2s		300V AC for 1 minute or 360V AC for 1s
Mechanical performance	Detent torque	20±11mN·m 40±16mN·m	36±16mN·m	40±14mN·m	40±10mN·m
	Push-pull strength	Push	100N		
		Pull	50N		100N
Shaft configuration		Ring type			
Terminal type		Insertion			
Switch Specifications	Switch type	—	—	—	—
	Contact arrangement	—	—	—	—
	Travel (mm)	—	—	—	—
	Operating force (N)	—	—	—	—
	Switch ON position	—	—	—	—
	Rotational torque	—	—	—	—
	Rating	—	—	—	—
	Contact resistance	—	—	—	—
	Operating life	—	—	—	—
Page		295	296	297	298

Encoders Soldering Conditions . . . . . 299  
 Encoders Cautions . . . . . 300

**Note**  
 ● Indicates applicability to all products in the series.

## Reference for Manual Soldering

Series	Tip temperature	Soldering time	No. of solders
EC05E, EC09E, EC10E, EC111, EC11B, EC11E, EC11G, EC11K, EC11M, EC11N, EC12D, EC12E, EC18A, EC21A, EC28A, EC35A, EC35AH, EC40A, EC45A, EC50A, EC60B, EM11B, EC21C, EC28C, EC35CH	350°C max.	3s max.	1 time
EC11J	350±10°C	3 <sup>+1</sup> <sub>0</sub> s	2 times

## Reference for Dip Soldering

Series	Preheating		Dip soldering		No. of solders
	Soldering surface temperature	Heating time	Soldering temperature	Soldering time	
EC09E, EC11B, EC111, EC11E, EC11G, EC11K, EC11M, EC11N, EC18A, EC21A, EC28A, EC35A, EC35AH, EC50A, EC60B	100°C max.	2 min. max.	260±5°C	5±1s	2 times max.
EM11B	100°C max.	1 min. max.	260°C max.	3s max.	2 times max.
EC10E, EC12D, EC12E	100°C max.	1 min. max.	260±5°C	3±1s	2 times max.
EC40A	110°C max.	1 min. max.	260°C max.	10s max.	1 time
EC45A	100°C max.	2 min. max.	260°C max.	5s max.	2 times max.

## Example of Reflow Soldering Condition

Temperature profile

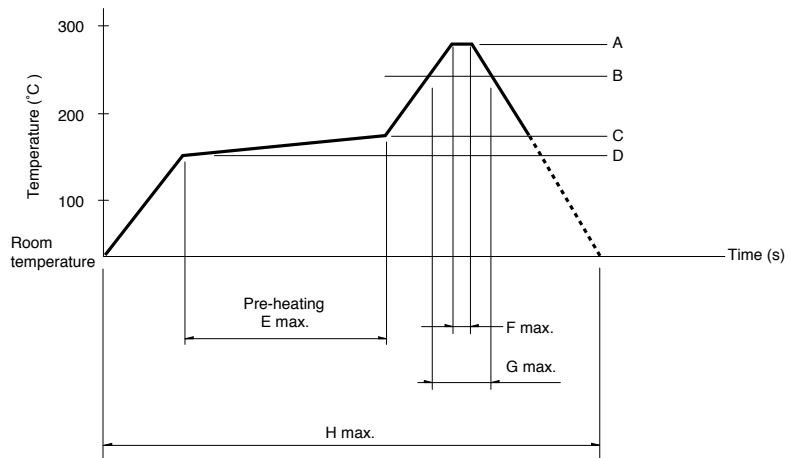

Series	A	B	C	D	E	F	G	H	No. of reflows
EC11J	260°C	230°C	180°C	150°C	2 min. max.	3s	40s	4 min. max.	2 times max.
EC05E	250°C min.	230°C min.	180°C	150°C	60s to 120s	—	30s to 40s	—	2 times max.
EC21C	230°C to 245°C	220°C	200°C	150°C	60s to 120s	—	25s to 60s	300s max.	1 time max.
EC28C, EC35CH	260°C	230°C	180°C	150°C	2 min. min.	3s	40s	230s max.	1 time max.

### Notes

- When using an infrared reflow oven, solder may sometimes not be applied. Be sure to use a hot air reflow oven or a type that uses infrared rays in combination with hot air.
- The temperatures given above are the maximum temperatures at the terminals of the encoder when employing a hot air reflow method. The temperature of the PC board and the surface temperature of the encoder may vary greatly depending on the PC board material, its size and thickness. Ensure that the surface temperature of the encoder does not rise to 250°C or greater.
- Conditions vary to some extent depending on the type of reflow bath used. Be sure to give due consideration to this prior to use.

# Mouser Electronics

Authorized Distributor

Click to View Pricing, Inventory, Delivery & Lifecycle Information:

[Alps Alpine:](#)

[EC45AG520402](#)