

The **SABRE9601 Headphone Driver** is the industry's highest performance, standalone headphone driver targeted for audiophile-grade portable applications such as mobile phones, tablets and digital music players.

The **SABRE9601 Headphone Driver** delivers 122dB SNR and -117dB THD+N, a new benchmark in standalone headphone driver performance that will satisfy the most demanding audio enthusiasts.

The **SABRE9601 Headphone Driver** is available in a 20-pin, 3mm x 3mm QFN package.

Like ESS' high-quality SABRE<sup>32</sup> Reference DACs, the **SABRE9601 Headphone Driver** sets the standard for HD Audio performance with **SABRE SOUND™** for today's most demanding audio applications.

FEATURE	DESCRIPTION
Unmatched performance <ul style="list-style-type: none"> <li>+122dB SNR</li> <li>-117dB THD+N: 2Vrms @ 600Ω load</li> <li>-100dB THD+N: 30mW into 32Ω load</li> </ul>	<ul style="list-style-type: none"> <li>Industry's highest performance audio headphone or line-out driver for mobile applications</li> <li>Delivers SABRE SOUND™ all the way to the headphones</li> </ul>
Ground reference output	<ul style="list-style-type: none"> <li>Eliminates large blocking capacitors</li> </ul>
Pop-noise suppression	<ul style="list-style-type: none"> <li>Powers up and down without any clicks or pops</li> </ul>
Charge pump for negative supply	<ul style="list-style-type: none"> <li>Single AVCC operation simplifies power supply</li> </ul>
20-QFN package, 3mm x 3mm	<ul style="list-style-type: none"> <li>Minimizes PCB footprint</li> </ul>
< 9mA / 5μA, quiescent / standby current	<ul style="list-style-type: none"> <li>Maximizes battery life</li> </ul>

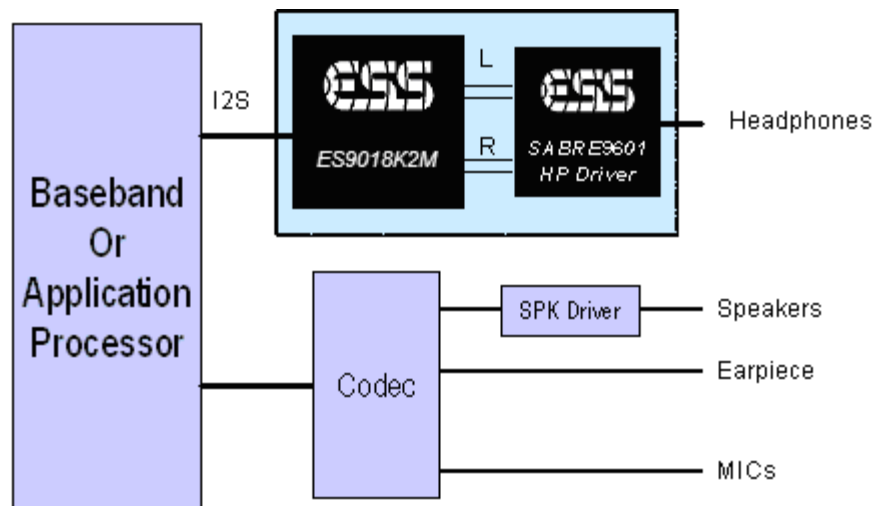



# SABRE9601K Headphone Driver Datasheet

## PIN LAYOUT

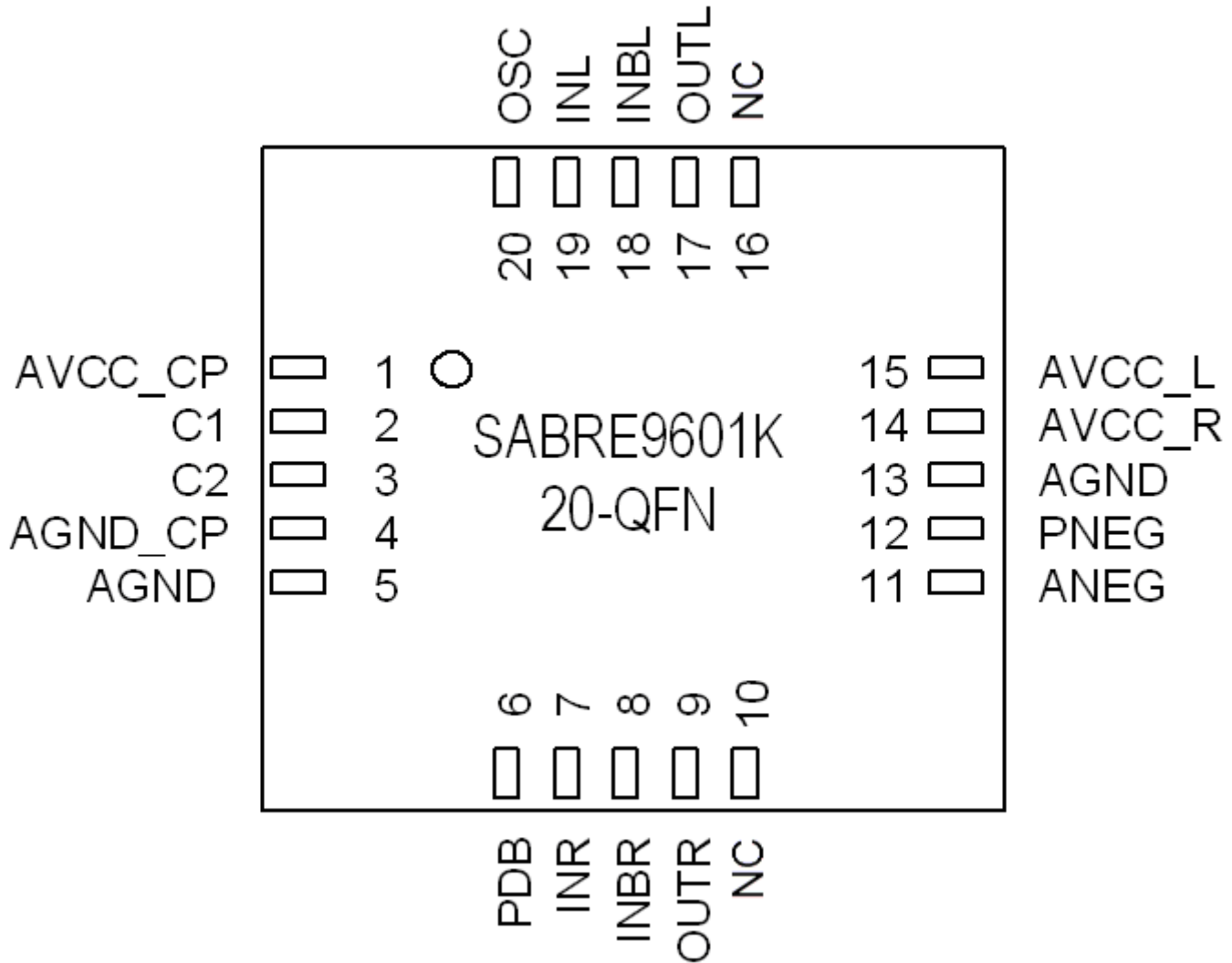

See note 1 on page 3 for name change information on pins 10 and 16.

# SABRE9601K Headphone Driver Datasheet



## PIN DESCRIPTIONS

Pin	Name	I/O	Description
1	AVCC_CP	-	Analog Power (Charge Pump)
2	C1	-	Positive Analog Flying Capacitor (connect a 2.2 $\mu$ F capacitor between C1 and C2, the capacitor value may be increased up to 4.7 $\mu$ F to improve regulation)
3	C2	-	Negative Analog Flying Capacitor Connection (connect a 2.2 $\mu$ F capacitor between C1 and C2, the capacitor value may be increased up to 4.7 $\mu$ F to improve regulation)
4	AGND_CP	-	Analog Ground (Charge Pump)
5	AGND	-	Analog Ground
6	PDB	I	Active-low Power Down (High for normal operation)
7	INR	I	Differential Positive Analog Input (Right Channel)
8	INBR	I	Differential Negative Analog Input (Right Channel)
9	OUTR	O	Analog Right Channel Output. A 4.7 $\Omega$ resistor should be placed between OUTR and the load to provide amplifier short-circuit protection
10	NC	NC	Do NOT make connections to this pin for new designs. Used on legacy designs only. See Note 1 below.
11	ANEG	I	Negative Amplifier Supply Input. Connect to PNEG when the internal charge pump is being used, and connect a 22 $\mu$ F minimum hold capacitor to ground. Increasing the hold capacitor value will improve supply regulation but increases start-up time.
12	PNEG	O	Negative Charge Pump Output. Connect to ANEG when the internal charge pump is being used, and connect a 22 $\mu$ F minimum hold capacitor to ground. Increasing the hold capacitor value will improve supply regulation but increases start-up time. PNEG is left open when an external -3.3V supply is used.
13	AGND	-	Analog Ground
14	AVCC_R	-	Analog Supply for the Right Channel
15	AVCC_L	-	Analog Supply for the Left Channel
16	NC	NC	Do NOT make connections to this pin for new designs. Used on legacy designs only. See Note 1 below.
17	OUTL	O	Analog Left Channel Output. A 4.7 $\Omega$ resistor should be placed between OUTL and the load to provide amplifier short-circuit protection
18	INBL	I	Differential Negative Analog Input (Left Channel)
19	INL	I	Differential Positive Analog Input (Left Channel)
20	OSC	I/O	Oscillator Input/Output pin. In normal operation, pin 20 outputs the charge-pump clock. When there is more than one SABRE9601, the OSC pins may be shorted together to synchronize the clocks and minimize potential "beat frequency effects". If the OSC pin is grounded, the charge-pump clock stops allowing an external -3.3V supply to be connected to ANEG (PNEG should be left open). An external clock can also be connected to the OSC pin and should be in the range 100kHz to 150kHz
-	PAD	-	Exposed pad. Connect to analog ground plane for heatsinking

### Note:

1. NC Pin 10 (formerly named INSR) and NC Pin 16 (formerly named INSL) retain the functions of INSR and INSL used in the application circuit in datasheets up to revision 1.2. However, for new designs we recommend using the revised application circuit of Figure 2 which minimizes the output offset voltage. All SABRE9601K devices will work in both new and old circuit designs.



## FUNCTIONAL DESCRIPTION

The SABRE9601 has a pair of CMOS FET input amplifiers that exhibit a total A-weighted SNR of better than 122dB when driving 2V<sub>rms</sub> into a 600Ω load. The SABRE9601 has an open-loop gain well in excess of 120dB which together with the input stage linearity is the key to its unparalleled –117dB distortion performance. Please note that the amplifier distortion performance far exceeds that of typical external passive components. Therefore, to achieve the THD performance specified for the SABRE9601, ensure that the external resistors have a very low, voltage coefficient of resistance, e.g. thin film resistors. Close tolerance, ±0.1%, thin-film resistors are recommended for all gain-defining components.

### Charge Pump

The SABRE9601 features a low-noise charge pump. The 120kHz switching frequency is above the audio band and, thus, does not interfere with audio signals. The switches are controlled by turn-on and turn-off transistors in a particular sequence that minimizes pops and clicks. The IC requires a 2.2μF minimum flying capacitor between pins C1 and C2 and a 22μF minimum hold capacitor from PNEG\_CP to AGND\_CP. The chip's OSC pin offers three connection options; capacitance may be added from OSC to ground to slow down the oscillator (100kHz minimum), a logic signal can drive the OSC pin to set a fixed frequency, or the OSC pins of several SABRE9601 chips may be connected together to force them to run synchronously.

### Charge-Pump Capacitor Selection

Use capacitors with an ESR less than 100mΩ for optimum performance. Low-ESR ceramic capacitors minimize the output resistance of the charge pump. For best performance over the extended temperature range select capacitors with a minimum X5R dielectric, the X7R dielectric is preferred. The charge pump can be disabled by grounding pin 20 which reduces quiescent current from the +3.3V supply. Disabling the charge pump is recommended when using an external –3.3V supply.

### Flying Capacitor (C4, see Figure 2)

The value of the flying capacitor (C4) affects the charge pump's load regulation and output resistance. A C4 value that is too small degrades the device's ability to provide sufficient current drive, which leads to a loss of output voltage. Increasing the value of C4 improves load regulation and reduces the charge-pump output resistance to an extent. With a 2.2μF flying capacitor, the on-resistance of the switches dominates. Use a low-ESR ceramic or electrolytic capacitor for C4. If an electrolytic capacitor is used the correct polarity must be observed, see Figure 2. The flying capacitor C4 can be eliminated when an external –3.3V supply is used and the internal oscillator is disabled by grounding the OSC pin.

### Hold Capacitor (C2, see Figure 2)

The hold capacitor value and ESR directly affect the ripple at PNEG\_CP. Use a low-ESR 22μF minimum capacitor for C2 and also choose the correct voltage rating. C2 can be a ceramic or electrolytic capacitor, if an electrolytic capacitor is used, the correct polarity must be observed, see Figure 2. Increasing the value of the hold capacitor will improve regulation but increases start-up time.

### Amplifier Gain

The recommended gain setting for SABRE9601 is 0dB (Unity gain). When working with ES901xK2M, only RF is needed. Since the RIN is the equivalent DAC output impedance, the recommend value for RF is 806Ω which gives the best DNR.

### Driving a Low-Impedance Load

In order to drive a 16Ω load it is necessary to use an external –3.3V supply and disable the internal charge pump. An external low-noise supply is required to source the high current drawn by the 16Ω load. Pin 20 should be grounded to stop the oscillator, PNEG is left open, and the external –3.3V supply is connected to ANEG with a 22μF minimum decoupling capacitor. To prevent clicks/pops at startup and shutdown the +3.3V and –3.3V supplies should be sequenced. The +3.3V must be ON and stay ON before connecting or disconnecting the -3.3V external supply.

### Compensation Components (see Figure 2)

For optimum performance, the following capacitors should be included in all configurations of the SABRE9601. C1 and C6 control the bandwidth of the SABRE9601, along with the matching networks C3 and C5. These compensation capacitors should have a low temperature coefficient. NP0/C0G types are recommended.

### Short-Circuit Protection (see Figure 2)

To protect the SABRE9601 under short-circuit conditions, 4.7Ω resistors should be placed in series with each output, OUTL and OUTR.

# SABRE9601K Headphone Driver Datasheet



## SABRE9601 Block Diagram

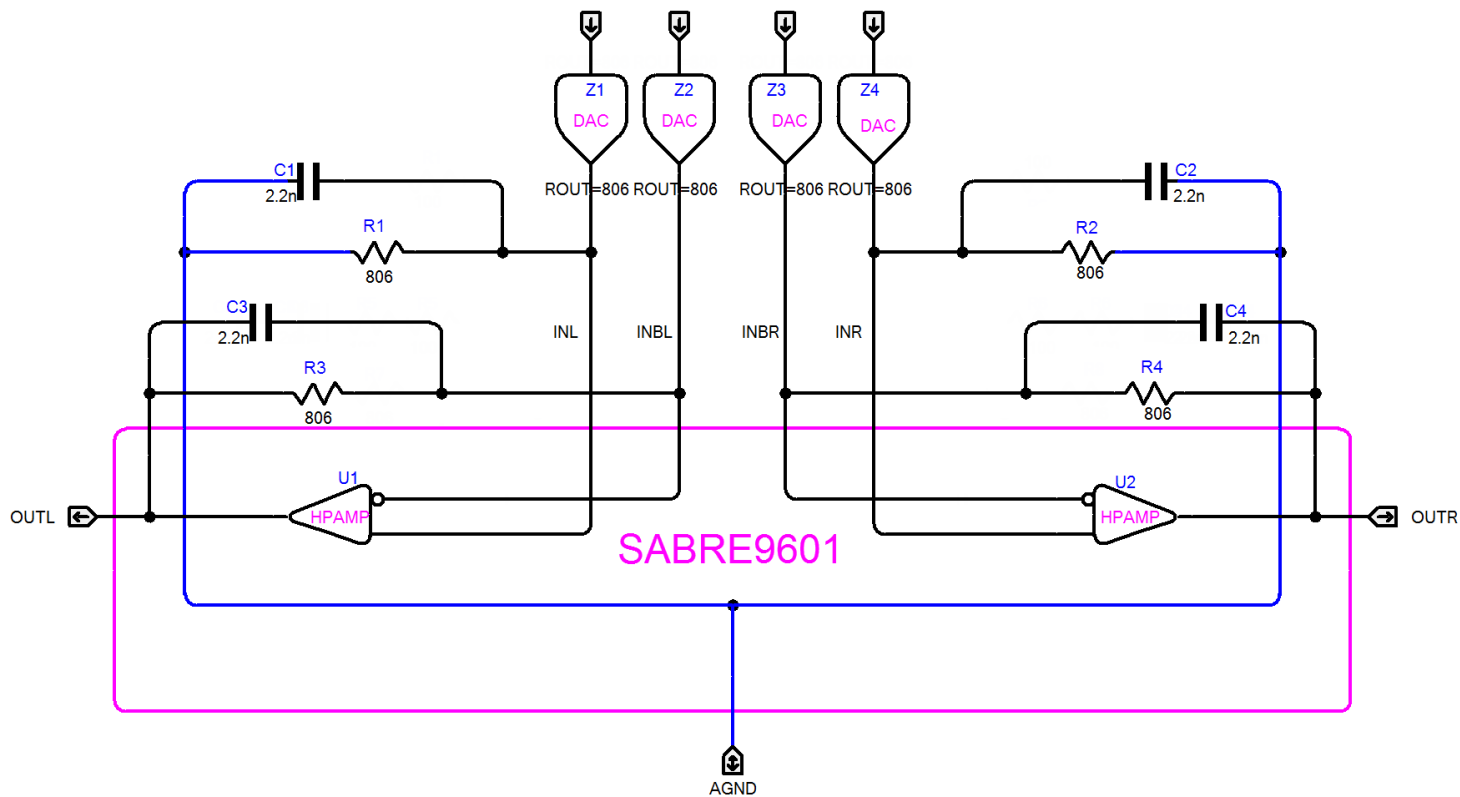

Figure 1. Block Diagram of the SABRE9601 plus external Gain Setting and Compensation components.



## APPLICATION DIAGRAM

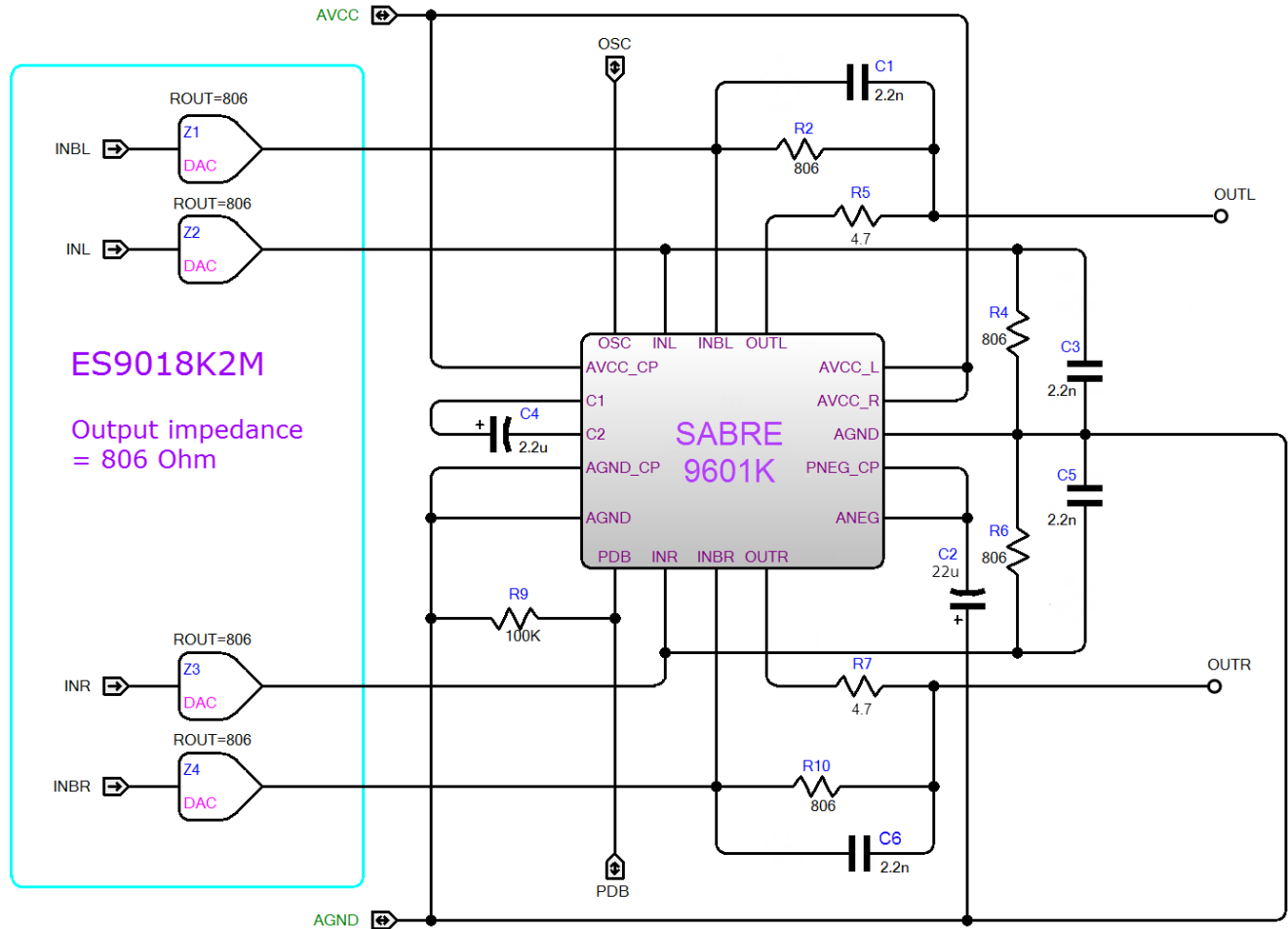

Figure 2. Schematic used to connect the ES9018K2M Dual SABRE DAC to the SABRE9601K Headphone Driver.

# SABRE9601K Headphone Driver Datasheet



## ABSOLUTE MAXIMUM RATINGS

PARAMETER	RATING
Positive Supply Voltage (AVCC_L, AVCC_R, AVCC_CP)	+4.7V with respect to GND
Negative Supply Voltage (ANEG & PNEG_CP)	-4.7V with respect to GND
Input Voltage (INL, INBL, INR, INBR)	ANEG < VIN < AVCC
Differential Input Voltage (INL, INBL, INR, INBR)	ANEG < VDiff < AVCC
Output Short-Circuit to GND (OUTL, OUTR)	Continuous with 4.7Ω protection resistors
Storage Temperature Range	-65°C to +150°C
Operating Junction Temperature	+125°C
Voltage range for digital input pins	-0.3V to DVCC+ 0.3V
ESD Protection	
Human Body Model (HBM)	2000V
Machine Model (MM)	200V

**WARNING:** Stresses beyond those listed under “Absolute Maximum Ratings” may cause permanent damage to the device. These are stress ratings only and functional operation of the device at these or any other conditions beyond those indicated under “recommended operating conditions” is not implied. Exposure to absolute-maximum-rated conditions for extended periods may affect device reliability.

**WARNING:** Electrostatic Discharge (ESD) can damage this device. Proper procedures must be followed to avoid ESD when handling this device.

## RECOMMENDED OPERATING CONDITIONS

PARAMETER	SYMBOL	CONDITIONS		
Operating Temperature Range	T <sub>A</sub>	-20°C to +70°C		
<b>Power Supply</b>		<b>Voltage</b>	<b>Quiescent Current (Note 1)</b>	<b>Standby Current (Note 2)</b>
Analog power supply voltage	AVCC_CP AVCC_L AVCC_R	+3.3V ± 5%	5.6mA typical, 9mA maximum	< 5μA
<b>Power Supply</b>		<b>Load Resistance</b>	<b>Supply Current</b>	<b>Output Voltage (Note 3)</b>
Analog supply current at +3.3V	I <sub>SY</sub>	32Ω	49mA typical	800mVrms @ 1kHz

### Notes

- 1) Input idling, output unloaded, internal oscillator, all external supply voltages at nominal center values
- 2) With PDB held low
- 3) 800mVrms sine wave across 32Ω load produces a 20mW output

## DC ELECTRICAL CHARACTERISTICS

Symbol	Parameter	Minimum	Maximum	Unit
V <sub>IH</sub>	High-level input voltage	1.4		V
V <sub>IL</sub>	Low-level input voltage		0.4	V

PARAMETER	SYMBOL	CONDITIONS	MIN	TYP	MAX	UNITS
Input Bias Current	I <sub>B</sub>	INL, INBL, INR, INBR	-1.0	0.1	+1.0	nA
Output Offset Voltage	V <sub>OS</sub>	OUTL to OUTR, no DC input	-2.0	0.1	+2.0	mV



## ANALOG PERFORMANCE

### Test Conditions (unless otherwise stated)

$T_A = 25^\circ\text{C}$ , AVCC\_CP = AVCC\_L = AVCC\_R = +3.3V, 1kHz signal, C2 = 22 $\mu\text{F}$ , C4 = 2.2 $\mu\text{F}$ , ANEG = PNEG (Figure 2 configuration)

1. SNR/DNR: A-weighted over 20Hz-20kHz in averaging mode
2. THD+N: un-weighted over 20Hz-20kHz bandwidth

PARAMETER	SYMBOL	CONDITIONS	MIN	TYP	MAX	UNITS
Signal-to-Noise Ratio	SNR	VOUT = 2.0Vrms, A-weighted, RL = 600 $\Omega$		122		dB
Total Harmonic Distortion plus Noise	THD+N	VOUT = 2.0Vrms, RL = 600 $\Omega$		-117		dB
		POUT = 30mW, RL = 32 $\Omega$		-100		dB
Power Supply Rejection	PSR	fin = 10Hz, 200mVp-p ripple	-	97	-	dB
		fin = 217Hz, 200mVp-p ripple	-	97	-	dB
		fin = 1kHz, 200mVp-p ripple	-	94	-	dB
		fin = 10kHz, 200mVp-p ripple	-	74	-	dB

### Test Conditions (unless otherwise stated)

$T_A = 25^\circ\text{C}$ , AVCC\_CP = AVCC\_L = AVCC\_R = +3.3V, 1kHz signal, C2 = 22 $\mu\text{F}$ , C4 = 2.2 $\mu\text{F}$ , OSC pin grounded, ANEG = -3.3V ext.

1. SNR/DNR: A-weighted over 20Hz-20kHz in averaging mode
2. THD+N: un-weighted over 20Hz-20kHz bandwidth

PARAMETER	SYMBOL	CONDITIONS	MIN	TYP	MAX	UNITS
Signal-to-Noise Ratio	SNR	VOUT = 2.0Vrms, A-weighted, RL = 600 $\Omega$		122		dB
Total Harmonic Distortion plus Noise	THD+N	VOUT = 2.0Vrms, RL = 600 $\Omega$		-117		dB
		VOUT = 1.4Vrms, RL = 32 $\Omega$		-100		dB
		VOUT = 1.0Vrms, RL = 16 $\Omega$		-97		dB
Power Supply Rejection	PSR	fin = 10Hz, 200mVp-p ripple	-	106	-	dB
		fin = 217Hz, 200mVp-p ripple	-	102	-	dB
		fin = 1kHz, 200mVp-p ripple	-	95	-	dB
		fin = 10kHz, 200mVp-p ripple	-	75	-	dB
		fin = 20kHz, 200mVp-p ripple	-	70	-	dB

## TYPICAL PERFORMANCE CURVES

The following typical performance curves are generated using ESS' evaluation board as shown in Figure 10. The internal charge pump is used to supply the negative rail. Measurements are taken using an Audio Precision Audio Analyzer. Note that all measurements in the graphs include errors due to the test equipment plus those of the ES9018K2M DAC on the evaluation board. Although these errors are very low, they are significant when measuring a state-of-the-art headphone amplifier like the SABRE9601K. Therefore the parametric values shown in the characteristic curves are slightly degraded compared to the values in the tables as the latter are calculated from measurements in near-ideal conditions.



# SABRE9601K Headphone Driver Datasheet



## TYPICAL PERFORMANCE CURVES

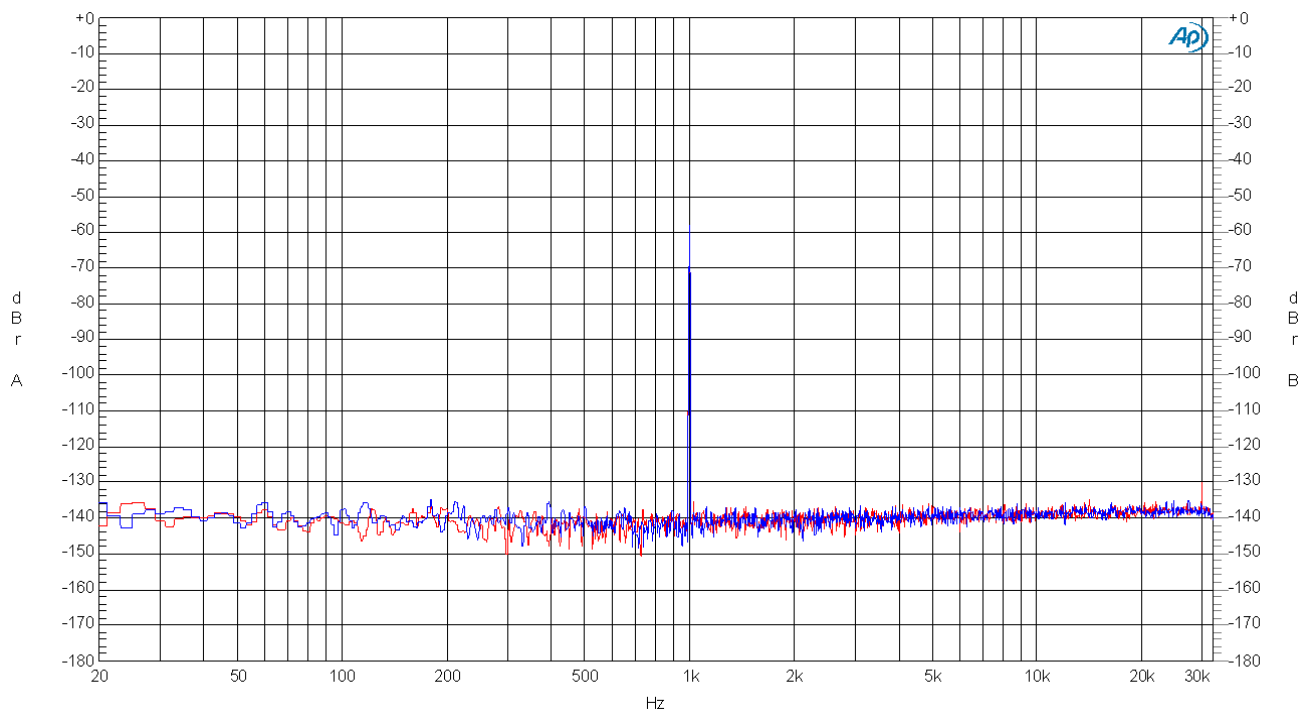

Figure 1 DNR FFT, 1kHz @ -60dB, Single-Ended, 32Ω Load

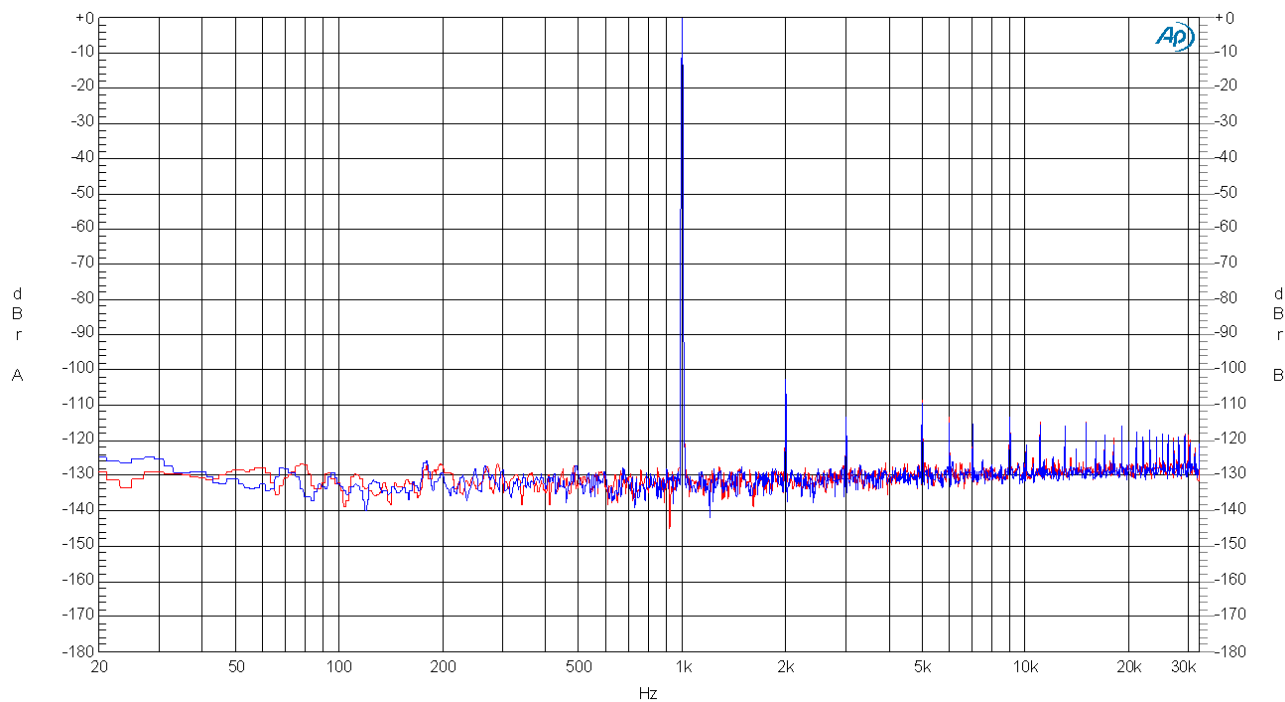

Figure 1 THD+N FFT, 1kHz @ 0dB, Single-Ended, 32Ω Load



TYPICAL PERFORMANCE CURVES

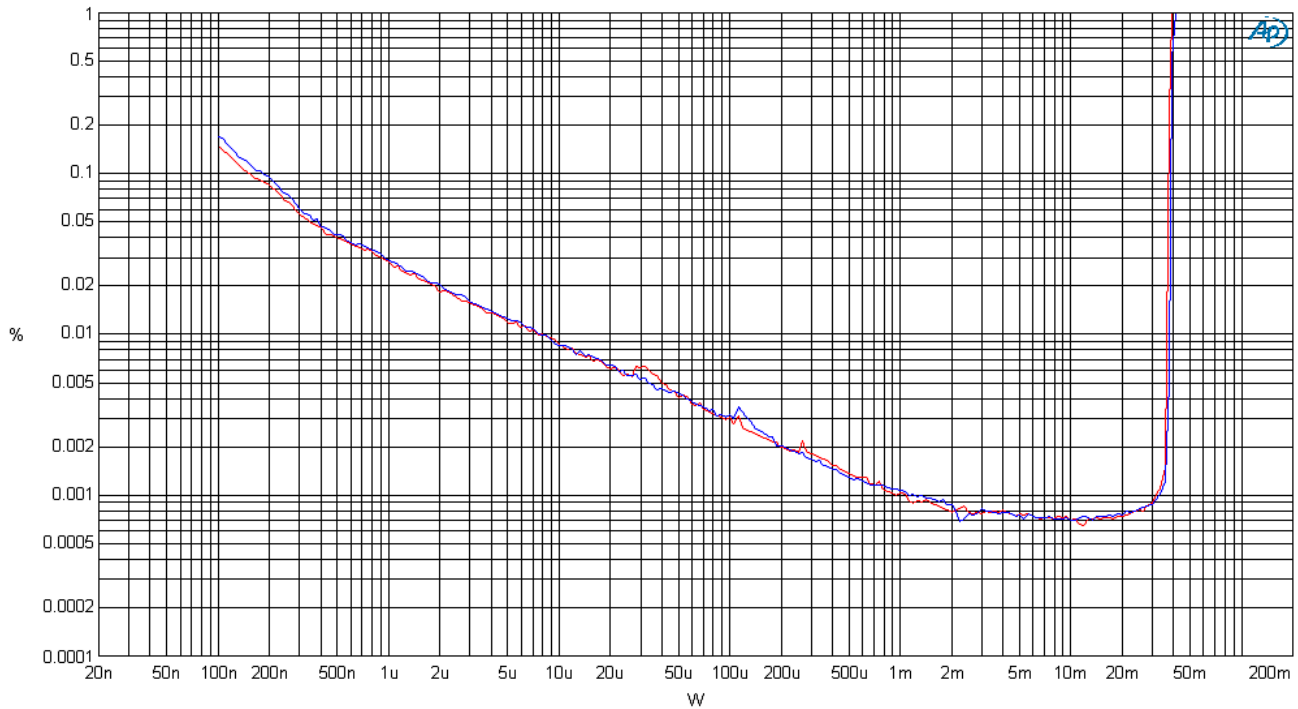

Figure 5. THD+N Unweighted vs. Output Power, Dual Channel Drive, Single Ended, 32Ω Load

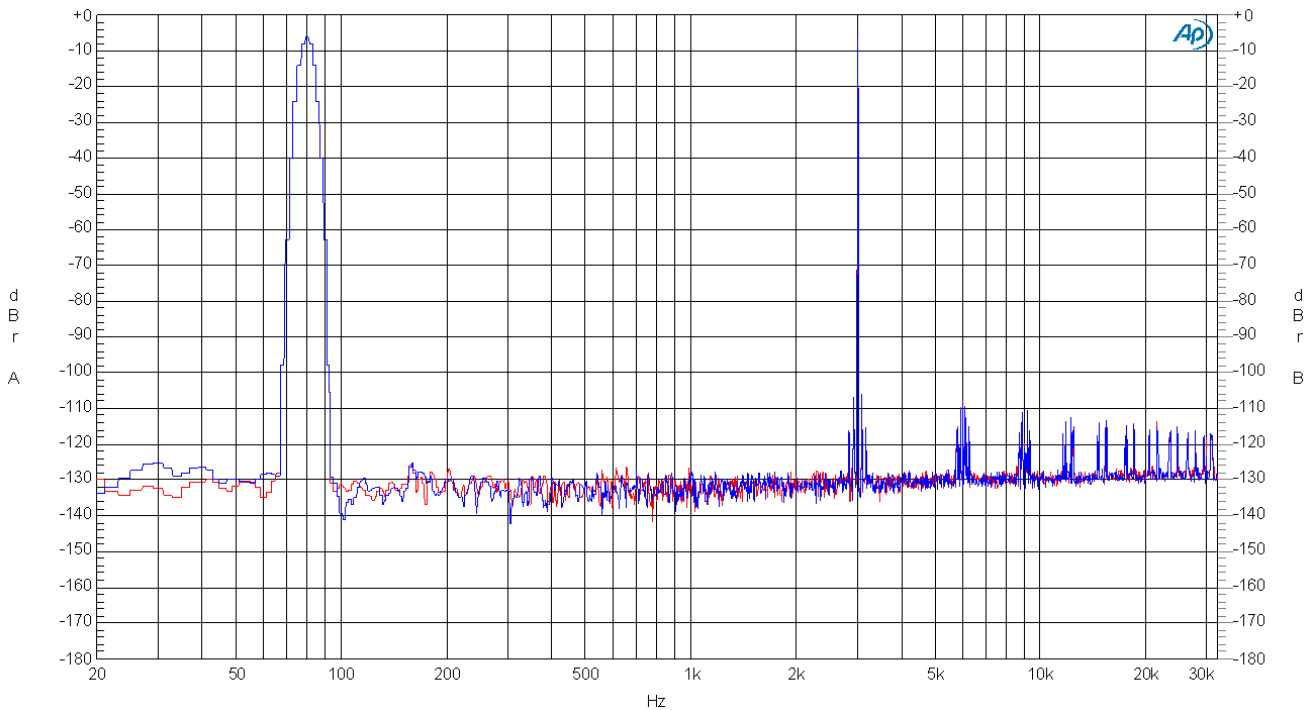

Figure 6. IMD FFT, 3kHz & 80Hz @ SMPTE 1:1, Single Ended, 32Ω Load

# SABRE9601K Headphone Driver Datasheet



## TYPICAL PERFORMANCE CURVES

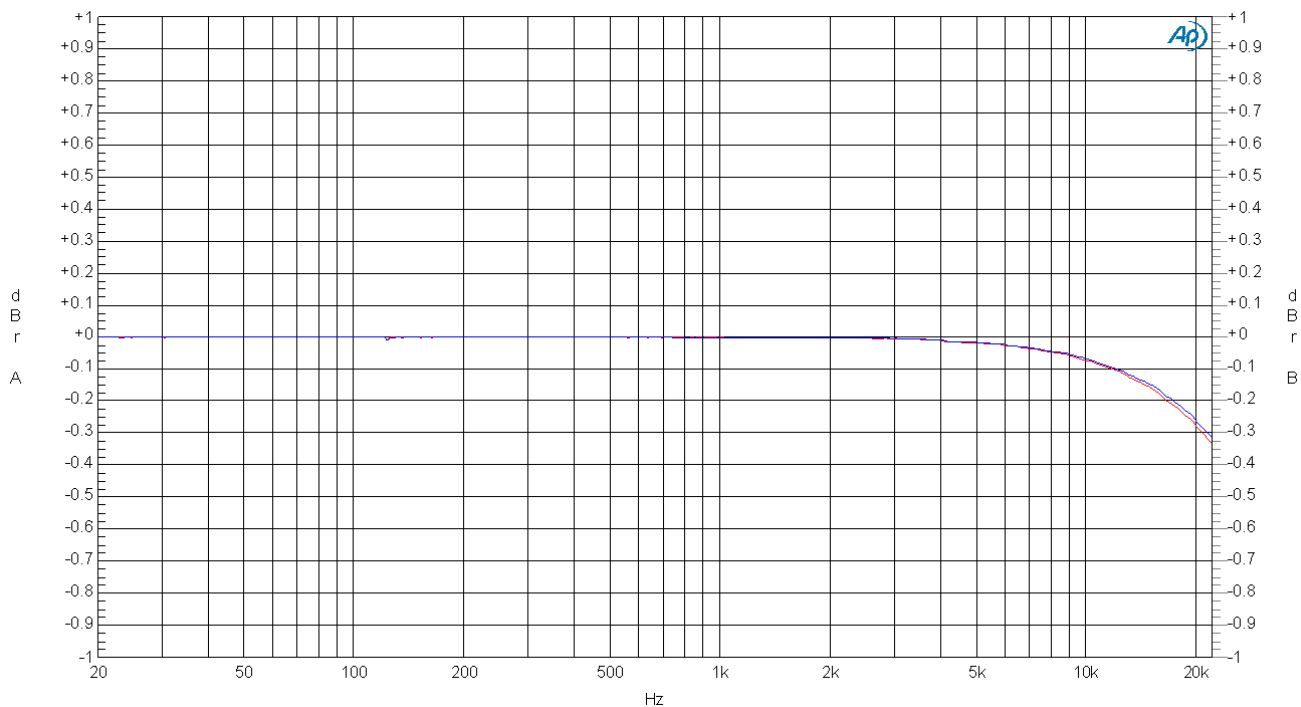

Figure 7. Frequency Response, 20Hz to 22kHz @ 0dB, Log Scale, Single Ended, 32Ω Load

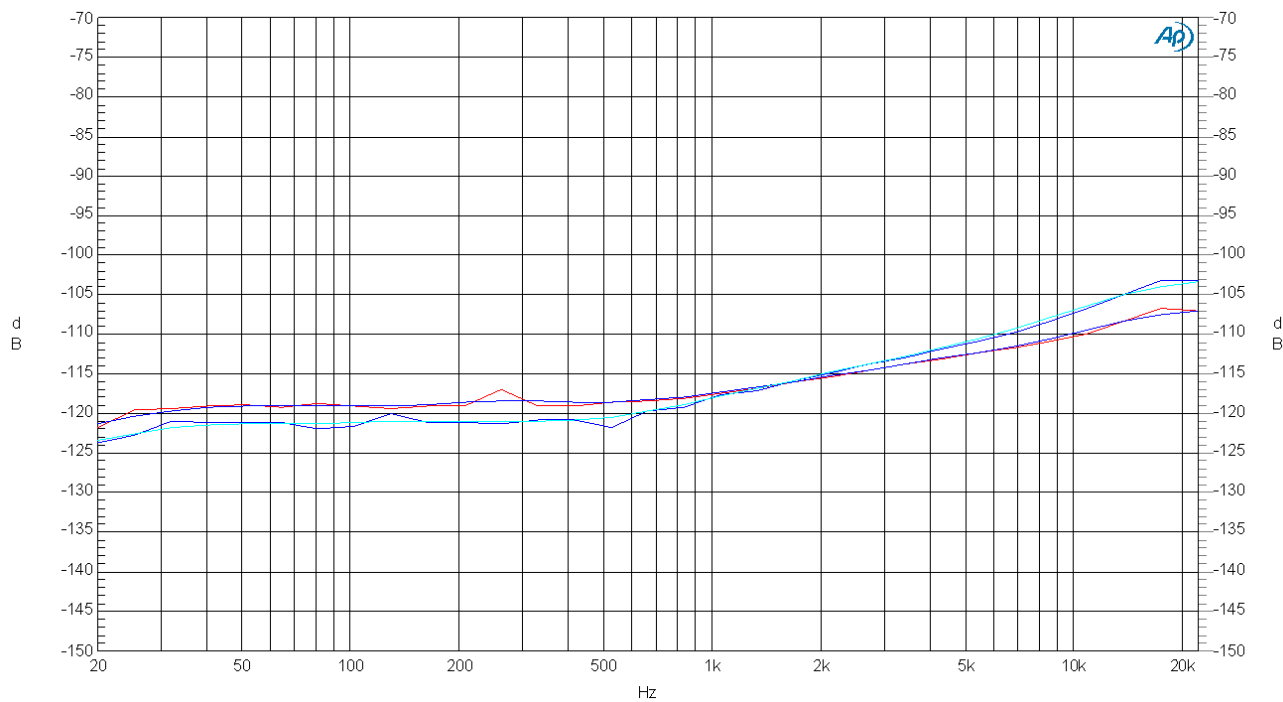

Figure 8. Crosstalk vs. Frequency, Single Ended, 32Ω Load



## TYPICAL PERFORMANCE CURVES

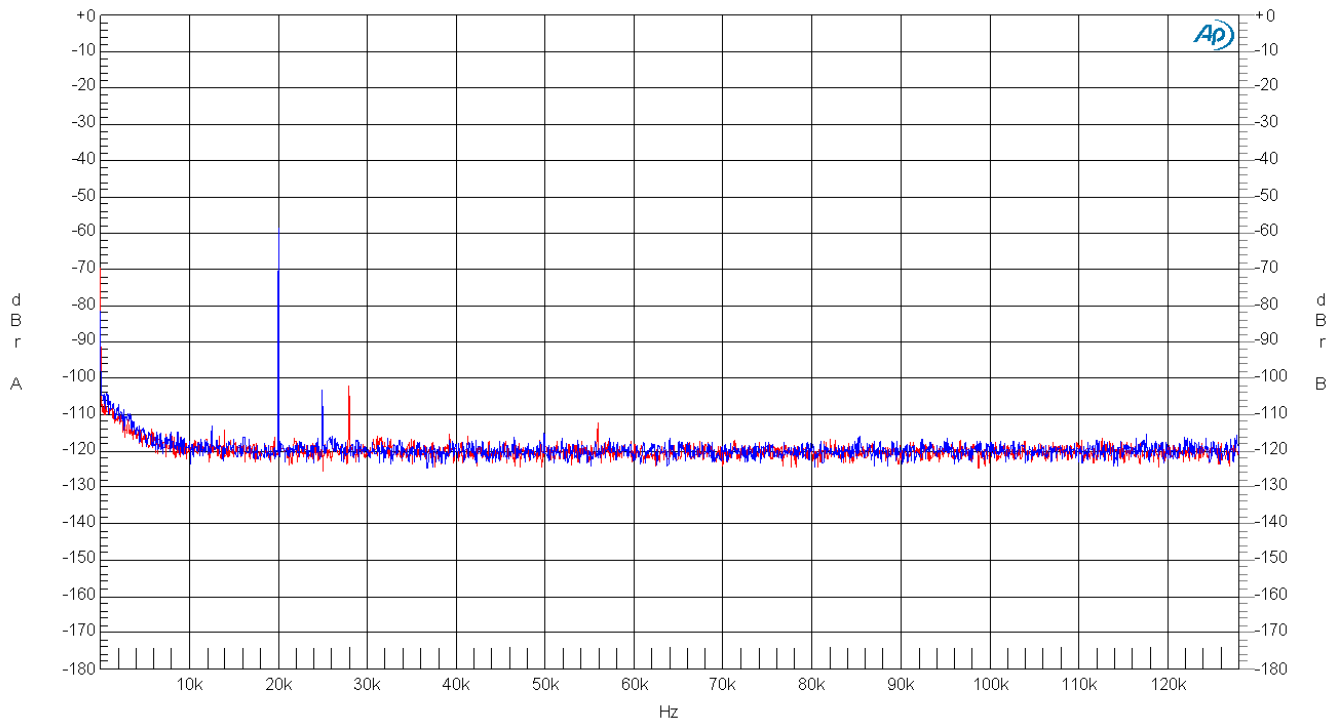

Figure 9. Wideband FFT, 20kHz @ -60dB, Single Ended, 32Ω Load

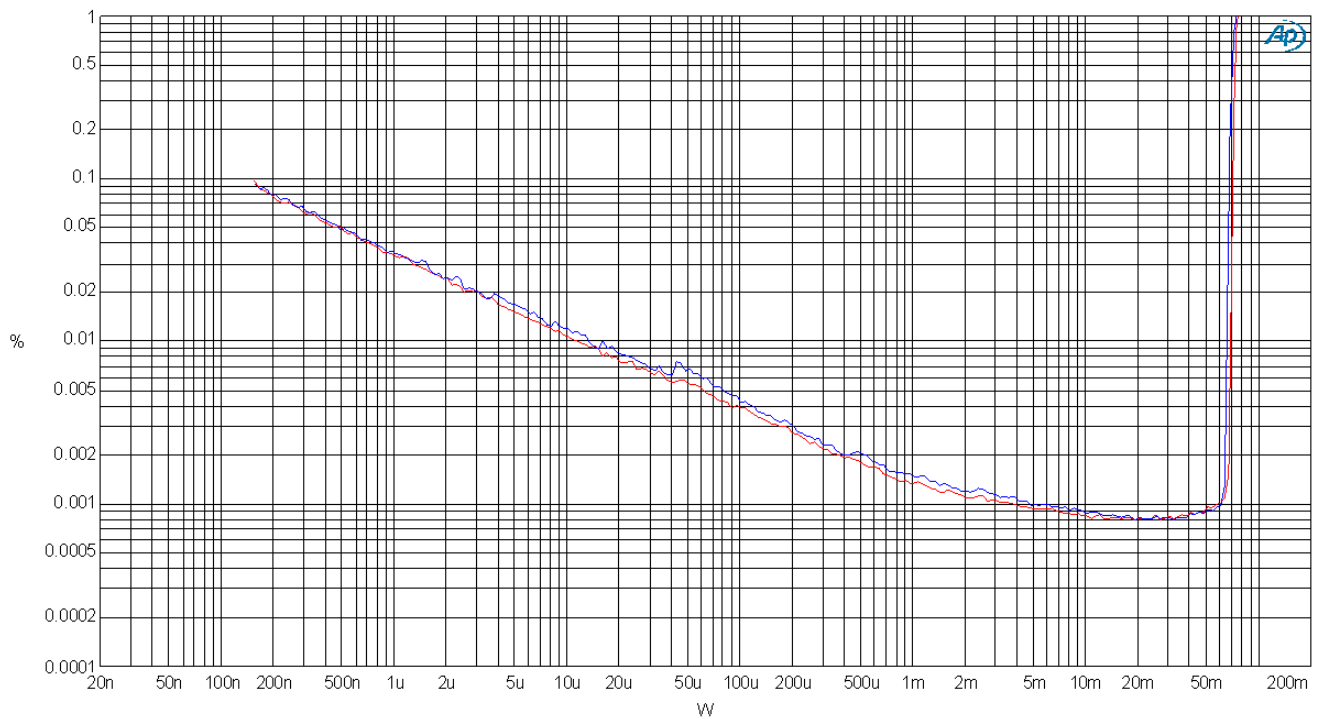
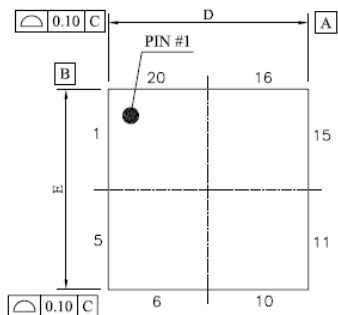

Figure 10. THD+N Unweighted vs. Output Power, Dual Channel Drive, Single Ended, 16Ω Load, external -3.3V supply

# SABRE9601K Headphone Driver Datasheet



## 20-Pin QFN Mechanical Dimensions



Top View

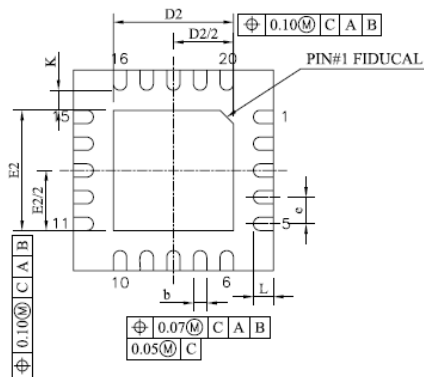

Bottom View

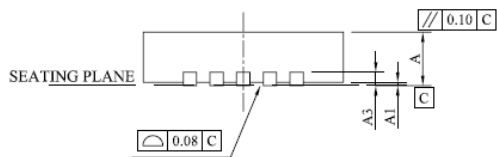

Side View

SYMBOL	DIMENSION (MM)			DIMENSION (MIL)		
	MIN.	NOM.	MAX.	MIN.	NOM.	MAX.
A	0.70	0.75	0.80	27.6	29.5	31.5
A1	0	0.02	0.05	0	0.8	2.0
A3	—	0.20REF	—	—	7.9REF	—
b	0.15	0.20	0.25	5.9	7.9	9.8
D	2.95	3.00	3.05	116.1	118.1	120.1
D2	1.75	1.80	1.85	68.9	70.9	72.8
E	2.95	3.00	3.05	116.1	118.1	120.1
E2	1.75	1.80	1.85	68.9	70.9	72.8
e	—	0.40BCS	—	—	15.7BCS	—
K	0.20	—	—	7.9	—	—
L	0.25	0.30	0.35	9.8	11.8	13.8

NOTE:

1. DIMENSIONING AND TOLERANCING CONFORM TO ASME Y14.5M-1994.
2. DIMENSION "b" APPLIES TO METALLIZED TERMINAL AND IS MEASURED BETWEEN 0.15 AND 0.25mm FROM TERMINAL TIP.
3. LEADFRAME MATERIAL IS 194FH AND THICKNESS IS 0.203MM (8 MIL).
4. DIMENSION "D" & "E" WILL INCLUDE ALL SIDE BURR INDUCED DURING ASSEMBLY.



## Example 20-Pin QFN Land Pattern

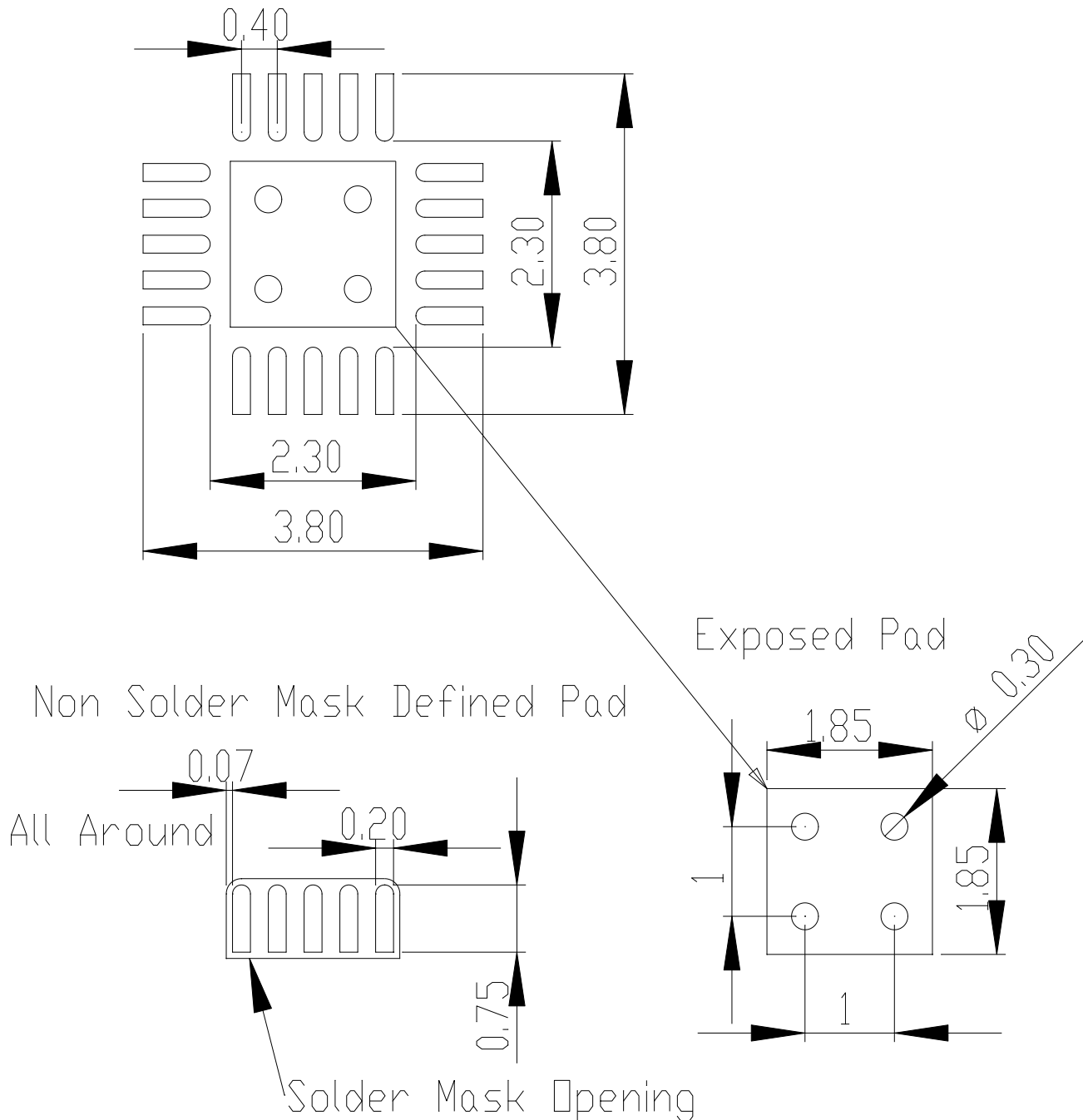

### Notes:

1. All dimensions are in millimeters.
2. Thermal vias should be 0.3mm to 0.33mm in diameter, with the barrel plated to 1oz copper.
3. For maximum solder mask in the corners, round the inner corners of each row.
4. Exposed pad should be solder mask defined.
5. For applications where solder loss through vias is a concern, plugging or tenting of the vias should be used. The solder mask diameter for each via should be 0.1mm larger than the via diameter.

# SABRE9601K Headphone Driver Datasheet



## Reflow Process Considerations

For lead-free soldering, the characterization and optimization of the reflow process is the most important factor you need to consider.

The lead-free alloy solder has a melting point of 217°C. This alloy requires a minimum reflow temperature of 235°C to ensure good wetting. The maximum reflow temperature is in the 245°C to 260°C range, depending on the package size (*Table RPC-2*). This narrows the process window for lead-free soldering to 10°C to 20°C.

The increase in peak reflow temperature in combination with the narrow process window makes the development of an optimal reflow profile a critical factor for ensuring a successful lead-free assembly process. The major factors contributing to the development of an optimal thermal profile are the size and weight of the assembly, the density of the components, the mix of large and small components, and the paste chemistry being used.

Reflow profiling needs to be performed by attaching calibrated thermocouples well adhered to the device as well as other critical locations on the board to ensure that all components are heated to temperatures above the minimum reflow temperatures and that smaller components do not exceed the maximum temperature limits (*Table RPC-2*).

To ensure that all packages can be successfully and reliably assembled, the reflow profiles studied and recommended by ESS are based on the JEDEC/IPC standard J-STD-020 revision D.1.

**Figure RPC-1.** IR/Convection Reflow Profile (IPC/JEDEC J-STD-020D.1)

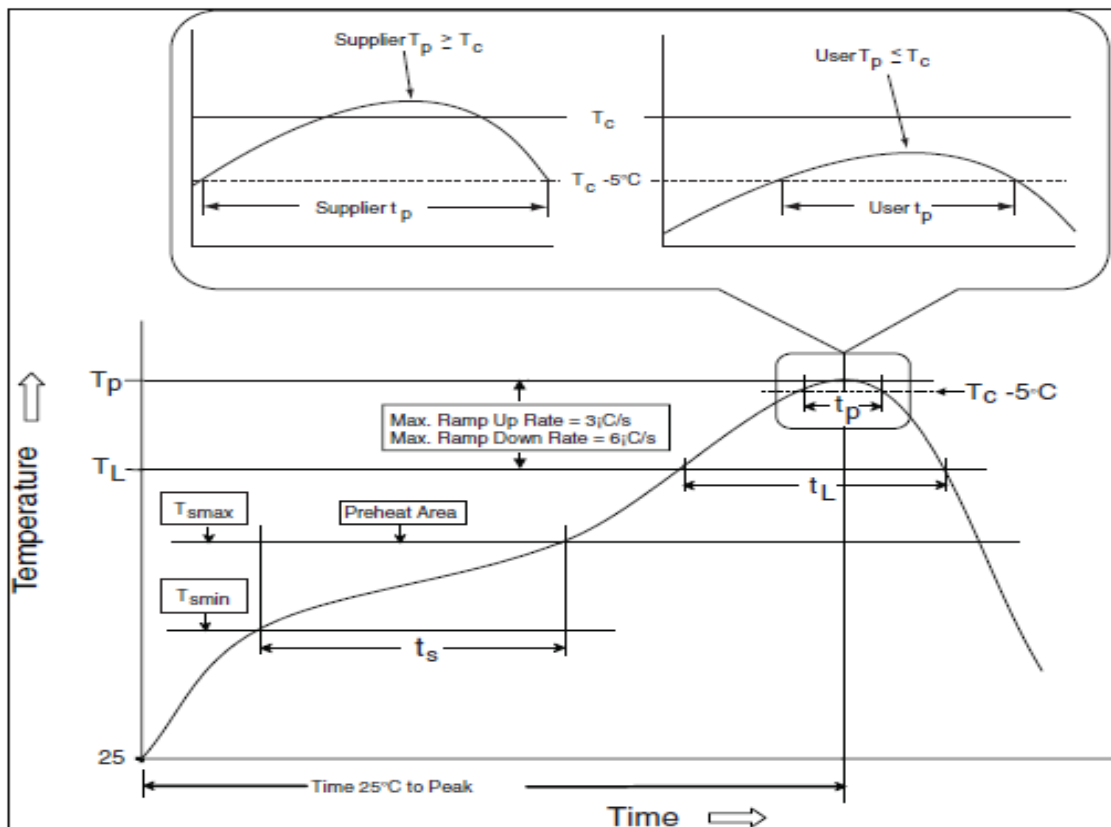

Note: Reflow is allowed 3 times. Caution must be taken to ensure time between re-flow runs does not exceed the allowed time by the moisture sensitivity label. If the time elapsed between the re-flows exceeds the moisture sensitivity time bake the board according to the moisture sensitivity label instructions.

### Manual Soldering:

Allowed up to 2 times with maximum temperature of 350 degrees no longer than 3 seconds.



## SABRE9601K Headphone Driver Datasheet

**Table RPC-1 Classification reflow profile**

Profile Feature	Pb-Free Assembly
<b>Preheat/Soak</b>	
Temperature Min (T <sub>min</sub> )	150°C
Temperature Max (T <sub>max</sub> )	200°C
Time (ts) from (T <sub>min</sub> to T <sub>max</sub> )	60-120 seconds
Ramp-up rate (TL to Tp)	3°C/second max.
Liquidous temperature (TL)	217°C
Time (tL) maintained above TL	60-150 seconds
Peak package body temperature (Tp)	For users Tp must not exceed the classification temp in Table RPC-2. For suppliers Tp must equal or exceed the Classification temp in Table RPC-2.
Time (tp)* within 5°C of the specified classification temperature (Tc), see Figure RPC-1	30* seconds
Ramp-down rate (Tp to TL)	6°C/second max.
Time 25°C to peak temperature	8 minutes max.
* Tolerance for peak profile temperature (Tp) is defined as a supplier minimum and a user maximum.	

**Note 1:** All temperatures refer to the center of the package, measured on the package body surface that is facing up during assembly reflow (e.g., live-bug). If parts are reflowed in other than the normal live-bug assembly reflow orientation (i.e., dead-bug), Tp **shall** be within  $\pm 2^\circ\text{C}$  of the live-bug Tp and still meet the Tc requirements, otherwise, the profile **shall** be adjusted to achieve the latter. To accurately measure actual peak package body temperatures refer to JEP140 for recommended thermocouple use.

**Note 2:** Reflow profiles in this document are for classification/preconditioning and are not meant to specify board assembly profiles. Actual board assembly profiles should be developed based on specific process needs and board designs and should not exceed the parameters in Table RPC-1. For example, if Tc is 260°C and time tp is 30 seconds, this means the following for the supplier and the user.  
For a supplier: The peak temperature must be at least 260°C. The time above 255°C must be at least 30 seconds.  
For a user: The peak temperature must not exceed 260°C. The time above 255°C must not exceed 30 seconds.

**Note 3:** All components in the test load **shall** meet the classification profile requirements.

**Table RPC-2 Pb-Free Process – Classification Temperatures (Tc)**

Package Thickness	Volume mm <sup>3</sup> , <350	Volume mm <sup>3</sup> , 350 to 2000	Volume mm <sup>3</sup> , >2000
<1.6 mm	260°C	260°C	260°C
1.6 mm – 2.5 mm	260°C	250°C	245°C
>2.5 mm	250°C	245°C	245°C

**Note 1:** At the discretion of the device manufacturer, but not the board assembler/user, the maximum peak package body temperature (Tp) can exceed the values specified in Table RPC-2. The use of a higher Tp does not change the classification temperature (Tc).

**Note 2:** Package volume excludes external terminals (e.g., balls, bumps, lands, leads) and/or non-integral heat sinks.

**Note 3:** The maximum component temperature reached during reflow depends on package thickness and volume. The use of convection reflow processes reduces the thermal gradients between packages. However, thermal gradients due to differences in thermal mass of SMD packages may still exist.



# SABRE9601K Headphone Driver Datasheet



## ORDERING INFORMATION

Part Number	Description	Package
SABRE9601K	Sabre Headphone Amp	20-pin QFN

The letter K identifies the package type QFN.

## Revision History

Rev.	Date	Notes
0.1	March 16, 2014	Initial release
0.2	May 12, 2014	Added land pattern
0.3	June 03, 2014	Corrected circuit error on page 4
0.4	June 03, 2014	Quiescent current value updated
0.5	June 10, 2014	Added typical operating current under load
0.6	June 25, 2014	Added more specifications and descriptive text
0.7	July 01, 2014	Increased minimum value of charge-pump hold capacitor from 2.2 $\mu$ F to 22 $\mu$ F. On page 7, THD+N into a 32 $\Omega$ load is now measured at 1Vrms. Updated FAX number for ESS Technology, Inc.
0.8	July 07, 2014	Figure 2 updated part numbers for SABRE9601 and ES9018.
0.9	July 09, 2014	Added 4.7 $\Omega$ output protection resistors to the simplified schematic of Figure 2, and "external -3.3V supply" is added to the description of Figure 9. Naming of SABRE9601 pins on Figure 10 updated to be consistent with Figure 2
1.0	July 30, 2014	Corrected page formatting errors
1.1	August 14, 2014	Corrected component references on page 2
1.2	September 16, 2014	Added I <sub>B</sub> and V <sub>OS</sub> specifications
1.3	October 2, 2014	Added specifications to the Absolute Maximum Ratings table. Updated Figure 1 block diagram to more accurately represent the internal circuit. Updated Figure 2 application circuit to minimize output offset voltage. Pins 10 and 16 changed from INSR and INSL to NC pins.
1.4	December 10, 2014	THD+N conditions changed with 32 $\Omega$ load impedance
1.41	April 30, 2015	Updated ESS' contact information
1.5	May 22, 2015	Removed four compensation resistors from the application circuit that are not required. Changed front page block diagram DAC to ES9018K2M.
1.6	August, 2022	Update HQ address

© 2021 ESS Technology, Inc.

ESS IC's are not intended, authorized, or warranted for use as components in military applications, medical devices or life support systems. ESS assumes no liability and disclaims any expressed, implied or statutory warranty for use of ESS IC's in such unsuitable applications.

No part of this publication may be reproduced, stored in a retrieval system, transmitted, or translated in any form or by any means, electronic, mechanical, manual, optical, or otherwise, without the prior written permission of ESS Technology, Inc. ESS Technology, Inc. makes no representations or warranties regarding the content of this document. All specifications are subject to change without prior notice. ESS Technology, Inc. assumes no responsibility for any errors contained herein. U.S. patents pending.

# Mouser Electronics

Authorized Distributor

Click to View Pricing, Inventory, Delivery & Lifecycle Information:

[ESS Technology:](#)

[SABRE9601K](#)