

50Ω 0.4 to 3.9 GHz

### The Big Deal

- Low Noise Figure, 0.6 dB typ. at 0.9 GHz, 4.5V
- High OIP3, +42.9 dBm typ. at 2 GHz, 4.5V
- Footprint compatible with ATF-501P8<sup>a,b</sup>



CASE STYLE: MC1631-1

### Product Overview

TAV2-501+ is an ultra-low noise, high IP3 transistor device, manufactured using E-PHEMT\* technology enabling it to work with a single positive supply voltage. It has outstanding Noise Figure, particularly below 2.5 GHz, and when combining this noise figure with high IP3 performance in a single device it makes it an ideal amplifier for demanding base station applications.

### Key Features

Feature	Advantages
Wideband, 0.4 to 3.9 GHz	A single device covers many wireless communications bands including cellular, ISM, GSM, WCDMA, WiMax, WLAN, and more.
High IP3 vs. DC power consumption <ul style="list-style-type: none"> <li>• +42.9 dBm at 0.9 GHz, 4.5V</li> <li>• +42.9 dBm at 2 GHz, 4.5V</li> <li>• +43.9 dBm at 3.9 GHz, 4.5V</li> </ul> For additional data, see Tables 1-4 on Page 5	The TAV2-501+ matches industry leading IP3 performance relative to device size and power consumption. Enhanced linearity over a broad frequency range makes the device ideal for use in: <ul style="list-style-type: none"> <li>• Driver amplifiers for complex waveform up converter paths</li> <li>• Drivers in linearized transmit systems</li> </ul>
High P1dB <ul style="list-style-type: none"> <li>• +30.6 dBm at 0.9 GHz, 4.5V</li> <li>• +27.7 dBm at 2 GHz, 4.5V</li> <li>• +30.0 dBm at 3.9 GHz, 4.5V</li> </ul> For additional data, see Tables 1-4 on Page 5	Results in a very dynamic range preventing amplifier saturation under strong interfering signals.
Combines high gain (16.4 dB) with very low Noise Figure (0.7 dB)	The unique combination of high gain and low Noise Figure results in lower overall system noise.
2 x 2mm 8-lead MCLP package	Tiny footprint saves space in dense layouts while providing low inductance, repeatable transitions, and excellent thermal contact to the PCB.

\* Enhancement mode Pseudomorphic High Electron Mobility Transistor.

a. Suitability for model replacement within a particular system must be determined by and is solely the responsibility of the customer based on, among other things, electrical performance criteria, stimulus conditions, application, compatibility with other components and environmental conditions and stresses.

b. The ATF-501P8 part number is used for identification and comparison purposes only.

# Low Noise, Medium Power E-PHEMT

## 0.4-3.9GHz

### Product Features

- Single Positive Supply Voltage
- Low Noise Figure, 0.6 dB at 0.9 GHz
- Gain, 15 dB at 2 GHz
- High Output IP3, 42.9 dBm at 2 GHz
- P1dB, 30.6 dBm at 0.9 GHz, 27.7 dBm at 2 GHz
- External biasing and matching required
- Footprint compatible with ATF-501P8<sup>a,b</sup>



Generic photo used for illustration purposes only

## TAV2-501+

CASE STYLE: MC1631-1

### Typical Applications

- Cellular
- ISM
- GSM
- WCDMA
- WiMax
- WLAN

**+RoHS Compliant**  
The +Suffix identifies RoHS Compliance. See our web site for RoHS Compliance methodologies and qualifications

### General Description

TAV2-501+ is an ultra-low noise, high IP3 transistor device, manufactured using E-PHEMT\* technology enabling it to work with a single positive supply voltage. It has outstanding Noise Figure, particularly below 2.5 GHz, and when combining this noise figure with high IP3 performance in a single device it makes it an ideal amplifier for demanding base station applications.

### simplified schematic and pad description

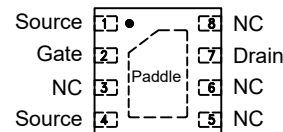
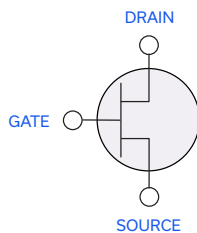

Function	Pad Number	Description
Source	1,4 & paddle	Source terminal, normally connected to ground
Gate	2	Gate used for RF input
Drain	7	Drain used for RF output
NC	3,5,6,8	No connecton, connected to ground externally

Notes:

- Suitability for model replacement within a particular system must be determined by and is solely the responsibility of the customer based on, among other things, electrical performance criteria, stimulus conditions, application, compatibility with other components and environmental conditions and stresses.
- The ATF-501P8 part number is used for identification and comparison purposes only.

Electrical Specifications at  $T_{AMB} = 25^{\circ}\text{C}$ , Frequency 0.4 to 3.9 GHz

Symbol	Parameter	Condition	Min.	Typ.	Max.	Units
<b>DC Specifications</b>						
VGS	Operational Gate Voltage	$V_{DS} = 4.5\text{ V}, I_{DS} = 280\text{ mA}$	0.39	0.52	0.65	V
VTH	Threshold Voltage	$V_{DS} = 4.5\text{ V}, I_{DS} = 28\text{ mA}$		0.38		V
IDSS	Saturated Drain Current	$V_{DS} = 4.5\text{ V}, V_{GS} = 0\text{ V}$		0.5		$\mu\text{A}$
GM	Transconductance	$V_{DS} = 4.5\text{ V}, G_M = \Delta I_{DS} / \Delta V_{GS}$ $\Delta V_{GS} = V_{GS1} - V_{GS2}$ $V_{GS1} = V_{GS}, \text{typ} - 0.05\text{ V}$ $V_{GS2} = V_{GS}, \text{typ} + 0.05\text{ V}$		2600		mS
IGSS	Gate Leakage Current	$V_{GD} = V_{GS} = -6.7\text{ V}$		65		$\mu\text{A}$
<b>RF Specifications, <math>Z_0 = 50\text{ Ohms}</math></b>						
NF <sup>(1)</sup>	Noise Figure	$V_{DS} = 4.5\text{ V}, I_{DS} = 280\text{ mA}$	$f = 0.9\text{ GHz}$ $f = 2.0\text{ GHz}$	0.6 1.3		dB
Gain <sup>(1,5)</sup>	Gain	$V_{DS} = 4.5\text{ V}, I_{DS} = 280\text{ mA}$	$f = 0.9\text{ GHz}$ $f = 2.0\text{ GHz}$	13.6 15.1	23.5 16.7	dB
OIP3 <sup>(1,6)</sup>	Output IP3	$V_{DS} = 4.5\text{ V}, I_{DS} = 280\text{ mA}$	$f = 0.9\text{ GHz}$ $f = 2.0\text{ GHz}$	40 42.9	42.9	dBm
P1dB <sup>(1,5)</sup>	Power Output at 1 dB Compression	$V_{DS} = 4.5\text{ V}, I_{DS} = 280\text{ mA}$	$f = 0.9\text{ GHz}$ $f = 2.0\text{ GHz}$	25.5 27.7	30.6	dBm
PAE <sup>(1,5)</sup>	Power Added Efficiency	$V_{DS} = 4.5\text{ V}, I_{DS} = 280\text{ mA}$	$f = 0.9\text{ GHz}$ $f = 2.0\text{ GHz}$	33 45	45	%

Absolute Maximum Ratings<sup>(3)</sup>

Symbol	Parameter	Max.	Units
$V_{DS}^{(3)}$	Drain-Source Voltage	7	V
$V_{GS}^{(3)}$	Gate-Source Voltage	-5 to +0.8	V
$V_{GD}^{(3)}$	Gate-Drain Voltage	-5 to +0.8	V
$I_{DS}^{(3)}$	Drain Current	500	mA
$I_{GS}$	Gate Current	60	$\mu\text{A}$
$P_{DISS}$	Total Dissipated Power	2.4	W
$P_{IN}^{(4)}$	RF Input Power	28	dBm
$T_{CH}$	Channel Temperature	150	$^{\circ}\text{C}$
$T_{OP}$	Operating Temperature	-40 to 85	$^{\circ}\text{C}$
$T_{STD}$	Storage Temperature	-65 to 150	$^{\circ}\text{C}$
$\Theta_{JC}$	Thermal Resistance	23	$^{\circ}\text{C}/\text{W}$

## Notes:

- (1) Measurements at 0.9 GHz obtained on Mini-Circuits characterization test board TB-TAV2-501+ with load and source pull test (Fig. 1), while measurements at 2 GHz tested on Mini-Circuits matching circuit test board TB-TAV2-501M+ (Fig. 2).
- (2) Operation of this device above any one of these parameters may cause permanent damage.
- (3) Assumes DC quiescent conditions.
- (4)  $I_{GS}$  is limited to 60  $\mu\text{A}$  during test.
- (5) Measurements at 0.9 GHz obtained for optimized P1dB.
- (6) Measurements at 0.9 GHz obtained for optimized IP3.

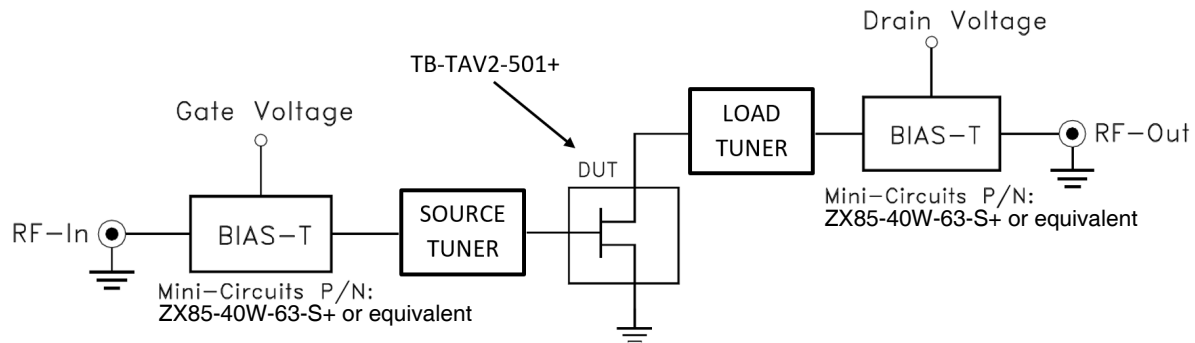

**Fig 1.** Block Diagram of Test Circuit used for characterization. (DUT soldered on Mini-Circuits Test Board TB-TAV2-501+) Gain, Output power at 1dB compression (P1 dB) and output IP3 (OIP3) are measured using Keysight Network Analyzer N5424A PNAX and Maury automated tuner.

**Conditions (Optimized IP3):**

1. Drain voltage (with reference to source, VDS) = 4.5V as shown.
2. Gate Voltage (with reference to source, VGS) is set to obtain desired Drain-Source current (IDS) as shown in specification table or load and source pull tables.
3. Gain: Pin= -25dBm
4. Pin for IP3: -10 dBm at 0.9 GHz, -5 dBm at 2.0 GHz, -1 dBm at 2.4 GHz, 0 dBm at 3.9 GHz.

**Conditions (Optimized P1dB):**

1. Drain voltage (with reference to source, VDS) = 4.5V as shown.
2. Gate Voltage (with reference to source, VGS) is set to obtain desired Drain-Source current (IDS) as shown in specification table or load and source pull tables.
3. Gain: Pin= -25dBm
4. Pin for IP3: -10 dBm at 0.9 GHz, -5 dBm at 2.0 GHz and 2.4 GHz, -2 dBm at 3.9 GHz.

**Recommended Application Circuit**

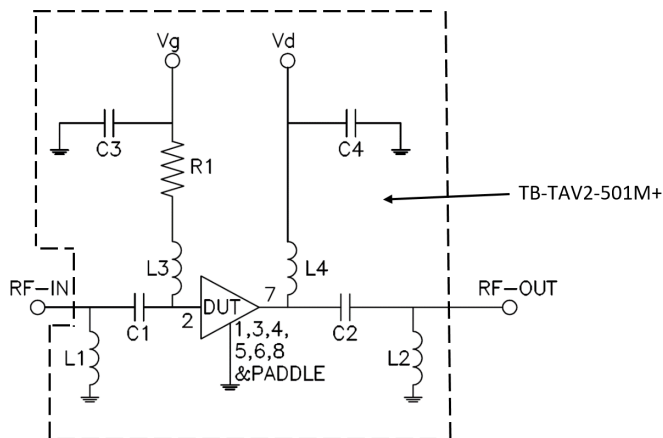

VDS, V (nom)	4.5
IDS, mA (nom)	280
R1	15 Ω
C1	2.4 pF
C2	2.4 pF
C3	2.2 μF
C4	2.2 μF
L1	1.2 nH
L2	1.5 nH
L3	15 nH
L4	47 nH

**Fig 2.** Recommended Application Circuit used for characterization. (DUT soldered on Mini-Circuits Matching Circuit Test Board TB-TAV2-501M+)

Table 1: Optimum OIP3 at 4.5 V, 280 mA

Freq (GHz)	OIP3 (dBm)	Gain (dB)	P1dB (dBm)	PAE (%)	$\Gamma_{\text{source}}$	$\Gamma_{\text{load}}$
0.9	45.11	19.98	29.85	49.66	0.694 $\angle$ - 114.29°	0.693 $\angle$ - 91.12°
2.0	46.32	14.22	28.68	48.82	0.842 $\angle$ 29.84°	0.715 $\angle$ 35.13°
2.4	44.64	11.23	27.44	42.12	0.724 $\angle$ 123.43°	0.638 $\angle$ 75.56°
3.9	43.89	11.00	27.83	42.76	0.884 $\angle$ - 108.07°	0.679 $\angle$ - 114.78°

Table 2: Optimum P1dB at 4.5 V, 280 mA

Freq (GHz)	OIP3 (dBm)	Gain (dB)	P1dB (dBm)	PAE (%)	$\Gamma_{\text{source}}$	$\Gamma_{\text{load}}$
0.9	40.18	22.77	30.03	52.30	0.658 $\angle$ - 87.51°	0.690 $\angle$ - 73.64°
2.0	41.52	17.02	30.23	56.73	0.743 $\angle$ 39.55°	0.715 $\angle$ 43.14°
2.4	41.11	15.10	30.52	53.56	0.742 $\angle$ 92.52°	0.720 $\angle$ 93.56°
3.9	39.53	11.72	29.95	46.67	0.759 $\angle$ - 95.66°	0.687 $\angle$ - 96.87°

Table 3: Optimum OIP3 at 4.5 V, 400 mA

Freq (GHz)	OIP3 (dBm)	Gain (dB)	P1dB (dBm)	PAE (%)	$\Gamma_{\text{source}}$	$\Gamma_{\text{load}}$
0.9	47.67	16.84	29.54	50.28	0.645 $\angle$ - 138.14°	0.602 $\angle$ - 69.95°
2.0	45.77	15.97	29.23	50.14	0.649 $\angle$ 40.96°	0.613 $\angle$ 40.33°
2.4	48.05	13.40	29.66	48.74	0.803 $\angle$ 112.01°	0.619 $\angle$ 92.12°
3.9	46.32	11.40	29.57	46.28	0.884 $\angle$ - 108.07°	0.684 $\angle$ - 105.84°

Table 4: Optimum P1dB at 4.5 V, 400 mA

Freq (GHz)	OIP3 (dBm)	Gain (dB)	P1dB (dBm)	PAE (%)	$\Gamma_{\text{source}}$	$\Gamma_{\text{load}}$
0.9	42.99	23.04	30.01	45.83	0.658 $\angle$ -87.51°	0.785 $\angle$ - 87.47°
2.0	42.01	18.53	30.68	48.45	0.833 $\angle$ 43.23°	0.827 $\angle$ 42.17°
2.4	44.45	17.26	30.16	55.62	0.874 $\angle$ 94.67°	0.726 $\angle$ 86.88°
3.9	43.13	12.90	30.83	49.36	0.875 $\angle$ -101.14°	0.784 $\angle$ - 99.28°

## Product Marking

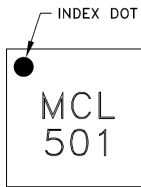

### Additional Detailed Technical Information

additional information is available on our dash board. To access this information [click here](#)

<b>Performance Data</b>	Data Table
	Swept Graphs
	S-Parameter (S2P Files) Data Set (.zip file)
<b>Case Style</b>	MC1631-1 Plastic low profile 2mm x 2mm, lead finish: matte-tin
<b>Tape &amp; Reel</b> Standard quantities available on reel	F66 7" reels with 20, 50, 100, 200, 500, 1K or 2K devices
<b>Suggested Layout for PCB Design</b>	PL-685, PL-688
<b>Test Board</b>	TB-TAV2-501+
<b>Evaluation Board (2GHz)</b>	TB-TAV2-501M+
<b>Environmental Ratings</b>	ENV08T2

## ESD Rating

Human Body Model (HBM): Class 1B (500V to < 1000V) in accordance with ANSI/ESD STM 5.1 - 2001

## MSL Rating

Moisture Sensitivity: MSL1 in accordance with IPC/JEDECJ-STD-020D

### MSL Test Flow Chart

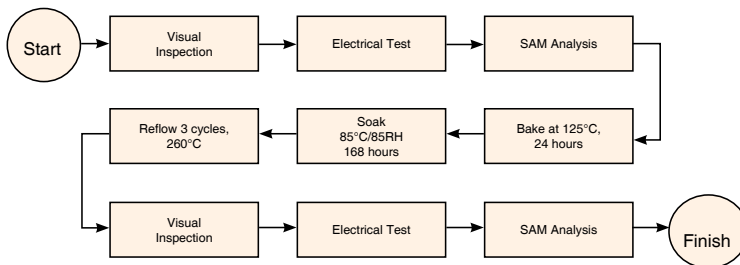

### Additional Notes

- Performance and quality attributes and conditions not expressly stated in this specification document are intended to be excluded and do not form a part of this specification document.
- Electrical specifications and performance data contained in this specification document are based on Mini-Circuit's applicable established test performance criteria and measurement instructions.
- The parts covered by this specification document are subject to Mini-Circuits standard limited warranty and terms and conditions (collectively, "Standard Terms"); Purchasers of this part are entitled to the rights and benefits contained therein. For a full statement of the Standard Terms and the exclusive rights and remedies thereunder, please visit Mini-Circuits' website at [www.minicircuits.com/MCLStore/terms.jsp](http://www.minicircuits.com/MCLStore/terms.jsp)

# Mouser Electronics

Authorized Distributor

Click to View Pricing, Inventory, Delivery & Lifecycle Information:

[Mini-Circuits:](#)

[TAV2-501+](#)