

Ceramic Balance Filter

50Ω 690 to 1570 MHz

Features

- Small size (0.126"x0.098"x0.039")
- Temperature stable
- Hermetically sealed
- LTCC construction

Applications

- ISM
- Cellular

BLFCV-1570+



Generic photo used for illustration purposes only

CASE STYLE: JV1210C-4

+RoHS Compliant

The +Suffix identifies RoHS Compliance. See our web site for RoHS Compliance methodologies and qualifications

Available Tape and Reel at no extra cost	
Reel Size	Devices/Reel
7"	20, 50, 100, 200, 500, 1000, 4000

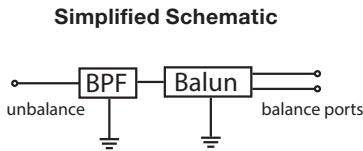

Electrical Specifications at 25°C

Parameter	F#	Frequency (MHz)	Min.	Typ.	Max.	Unit
Impedance Ratio			2:1			
Insertion Loss	F1-F2	690 - 1570	—	—	3.0	dB
Attenuation		2200-5050	25	—	—	dB
		5050-6000	20	—	—	dB
Amplitude Unbalance		690 - 1570	—	—	1.5	dB
Phase Unbalance		690 - 1570	—	—	15	degree
Input VSWR		690 - 1570	—	1.78	—	:1

Maximum Ratings

Operating Temperature	-55°C to +105°C
Storage Temperature	-55°C to +105°C
RF Power Input*	1W @25°C

* Refer to product storage temperature after installation
Suggestion for T&R unused product storage condition: +5 ~ +35 °C,
Humidity 45-75%RH, 12 month Max

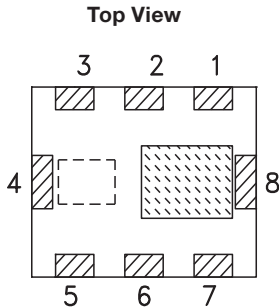

Pad Connections

Unbalanced Port	7
Balanced Port	3, 5
GND	2, 4, 8
GNC or DC Feed	6
NC	1

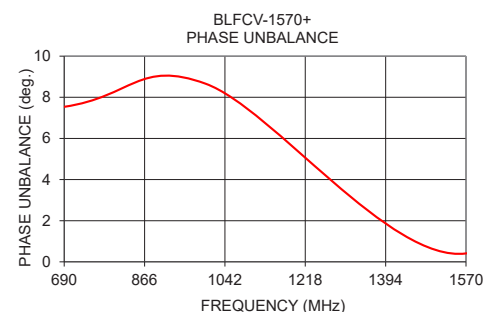
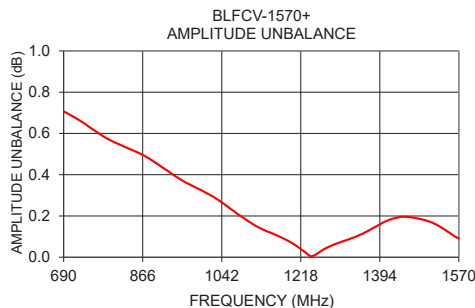
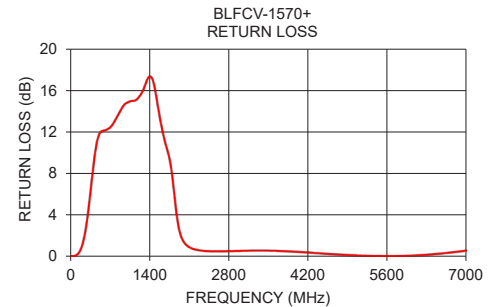
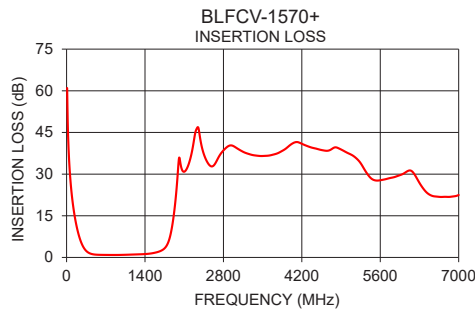

Typical Performance Data

Frequency (MHz)	Insertion Loss (dB)	Return Loss (dB)	Amplitude Unbalance (dB)	Phase Unbalance (Deg.)
10	60.98	0.04	2.72	31.03
50	33.22	0.05	2.49	9.47
100	21.27	0.14	2.27	5.68
690	0.91	12.38	0.71	7.54
1000	0.93	14.80	0.32	8.66
1570	1.67	13.49	0.09	0.41
2000	34.43	1.38	6.11	11.55
2500	34.77	0.51	3.43	27.47
3000	39.84	0.55	3.20	37.34
3500	36.52	0.57	1.36	30.47
4000	40.59	0.45	9.38	85.68
4500	38.92	0.27	0.20	158.12
5000	37.79	0.12	4.09	170.46
5500	27.79	0.05	0.06	65.38
6000	30.01	0.08	10.33	69.21
7000	22.48	0.58	4.00	84.49

Outline Drawing

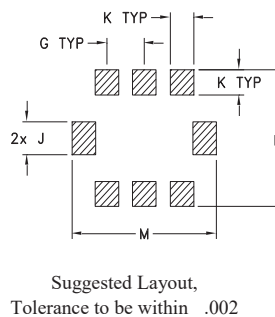
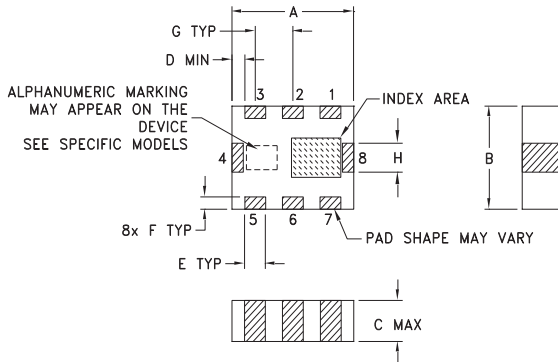

Demo Board MCL P/N: TB-1053+ Suggested PCB Layout (PL-632)

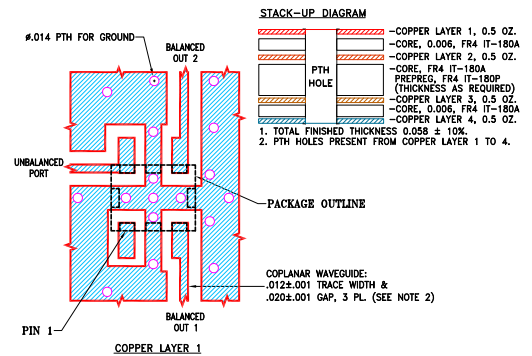

- NOTES:
- PCB IS MULTILAYER PCB, SEE STACK-UP DIAGRAM.
 - TRACE WIDTH & GAP PARAMETERS ARE SHOWN FOR FR4 IT-180A WITH DIELECTRIC THICKNESS .006"±.0007"; COPPER: 1/2 OZ. FOR OTHER MATERIALS TRACE WIDTH AND GAP MAY NEED TO BE MODIFIED.
 - LAYERS 2,3,4 OF THE PCB ARE CONTINUOUS GROUND PLANE.
- DENOTES COPPER LAND PATTERN FREE OF SOLDER MASK

Outline Dimensions (Inch/mm)

A	B	C	D	E	F	G
.126	.098	.039	.004	.022	.012	.039
3.2	2.5	1.0	0.1	0.56	0.3	1.0
H	J	K	L	M		wt
.028	.031	.024	.130	0.15		grams
0.7	0.8	0.6	3.30	3.81		0.030

Additional Notes

- Performance and quality attributes and conditions not expressly stated in this specification document are intended to be excluded and do not form a part of this specification document.
- Electrical specifications and performance data contained in this specification document are based on Mini-Circuit's applicable established test performance criteria and measurement instructions.
- The parts covered by this specification document are subject to Mini-Circuits standard limited warranty and terms and conditions (collectively, "Standard Terms"); Purchasers of this part are entitled to the rights and benefits contained therein. For a full statement of the Standard Terms and the exclusive rights and remedies thereunder, please visit Mini-Circuits' website at www.minicircuits.com/MCLStore/terms.jsp

Mouser Electronics

Authorized Distributor

Click to View Pricing, Inventory, Delivery & Lifecycle Information:

[Mini-Circuits:](#)

[BLFCV-1570+](#)