

DO NOT SCALE FROM THIS PRINT

NOTES:

1. Ⓢ REPRESENTS A CRITICAL DIMENSION.
2. TUBE POSITIONS -05 THRU -36 ONLY; POSITIONS -02 THRU -04 TO BE LAYER PACKAGED.
3. MAXIMUM CUT FLASH: .020 [0.51] CUT FLASH TO BE IN A NON-CRITICAL AREA LOCATED BETWEEN BODIES.

HW-XX-XX-XX-X-XXXX-SM-X-XXX

No OF POSITIONS  
-02 THRU -36  
LEAD STYLE  
(SEE TABLE 1)

OPTION #2  
POLARIZED POSITION  
SPECIFY OMITTED PIN

OPTION #1  
-LC: LOCKING CLIP (SEE FIG 2, SHT 2)  
(-D: USE RTSM-50-DVU, USE LC-05-TM)  
(-S: USE TSM-50-SV BODY, USE LC-08-TM-02)

-A: ALIGNMENT PIN (SEE FIG 3, SHT 2)  
(-S: 3 POSITION USE TSM-03-SV-A, MUST BE MOLDED TO POSITION)  
(4-50 POSITIONS USE TSM-XX-SV-XX, 2 POSITIONS TO USE TSM-48-SV-04)  
(-D: FOR MOLDED TO POSITION, USE RTSM-50-DVU-XX BODY, AVAILABLE ON POS -02 THRU -36)  
(-D: FOR STAKED, USE RTSM-50-DVU BODY, 3 POS MIN)

-TR: TAPE & REEL  
(27 MAX POSITIONS)  
(MAX HEIGHT: .6875)

LEAVE BLANK FOR NO HOLD DOWN OPTION  
(-D: USE RTSM-50-DVU, CAN BE CUT TO POSITION, SEE FIG 1)  
(-S: USE TSM-50-SV, CAN BE CUT TO POSITION, SEE FIG 1)

SURFACE MOUNT

PLATING SPECIFICATION

- T: MATTE TIN ON CONTACT AND TAIL.
- S: 30μ" SELECTIVE GOLD IN CONTACT AREA, MATTE TIN ON TAIL.
- G: 10μ" SELECTIVE GOLD IN CONTACT AREA, 3μ" SELECTIVE GOLD ON TAIL.
- L: 10μ" SELECTIVE GOLD IN CONTACT AREA, MATTE TIN ON TAIL.
- TL: 250μ" TIN/LEAD ON CONTACT AND TAIL.
- H: 30μ" SELECTIVE GOLD IN CONTACT AREA, 3μ" SELECTIVE GOLD ON TAIL.
- F: 3μ" SELECTIVE GOLD IN CONTACT AREA, MATTE TIN ON TAIL.
- TM: MATTE TIN ON CONTACT AND TAIL.
- SM: 30μ" SELECTIVE GOLD IN CONTACT AREA, MATTE TIN ON TAIL.
- LM: 10μ" SELECTIVE GOLD IN CONTACT AREA, MATTE TIN ON TAIL.
- FM: 3μ" SELECTIVE GOLD IN CONTACT AREA, MATTE TIN ON TAIL.

ROW OPTION

- D: DOUBLE ROW  
(USE RTSM-50-DVU FOR BOTTOM INSULATOR)  
(USE WRTSM-50-DVU FOR TOP INSULATOR)
- S: SINGLE ROW  
(USE TSM-XX-S BODY FOR BOTTOM INSULATOR)  
(USE WTSM-50-SV FOR TOP INSULATOR)

BOARD SPACE  
"A" = -XXX  
(SEE FIG 1 & TABLE 1)  
MAX = C + .150

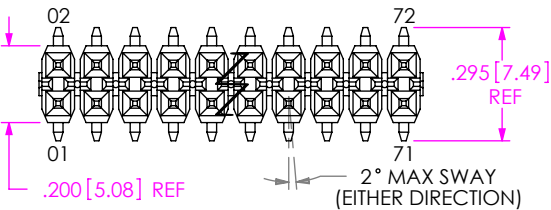
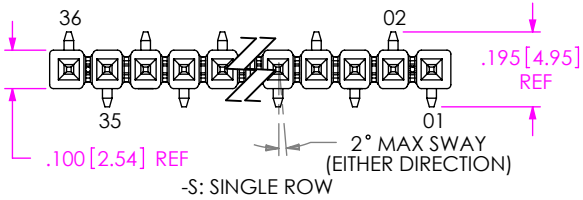
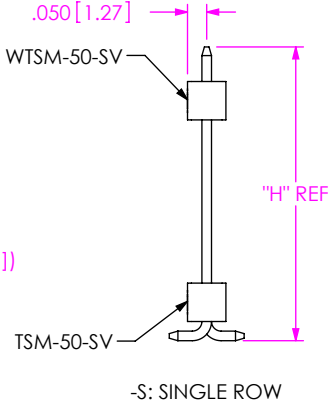
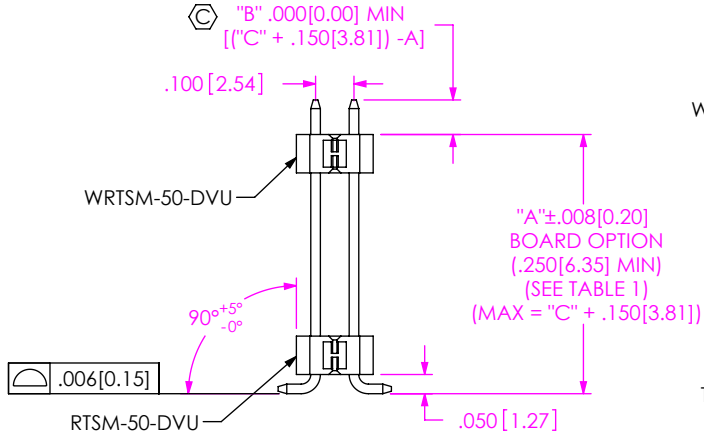
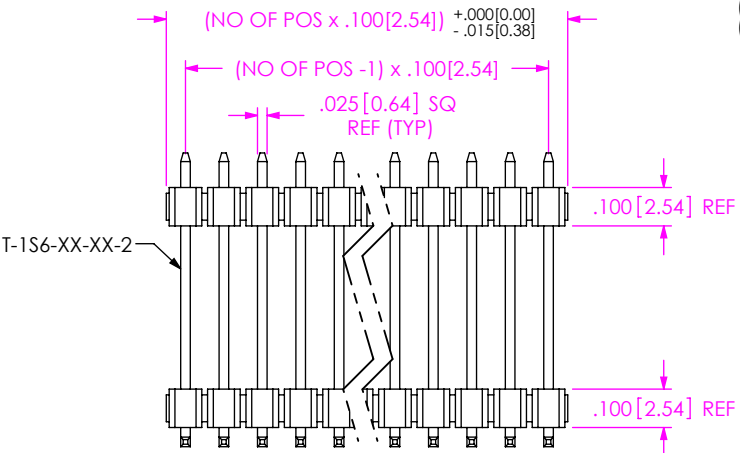

FIG 1  
HW-XX-10-XX-X-375-SM SHOWN



LEAD STYLE	TERMNAL	"H"	"A" WHEN "B" IS .090 [2.29]	"C"	IN-PROCESS OAL REF
-08	T-1S6-08-XX-2	.465 [11.81]	.375 [9.53]	.315 [8.00]	.530 [13.46]
-09	T-1S6-09-XX-2	.665 [16.89]	.575 [14.61]	.515 [13.08]	.730 [18.54]
-10	T-1S6-10-XX-2	.765 [19.43]	.675 [17.15]	.615 [15.62]	.830 [21.08]
-11	T-1S6-11-XX-2	.865 [21.97]	.775 [19.69]	.715 [18.16]	.930 [23.62]
-12	T-1S6-12-XX-2	.965 [24.51]	.875 [22.23]	.815 [20.70]	1.030 [26.16]
-15	T-1S6-15-XX-2	.565 [14.35]	.475 [12.07]	.415 [10.54]	.630 [16.00]
-16	T-1S6-16-XX-2	.380 [9.65]	.290 [7.37]	.230 [5.84]	.445 [11.30]
-17	T-1S6-17-XX-2	.415 [10.54]	.325 [8.26]	.265 [6.73]	.480 [12.19]
-20	T-1S6-20-XX-2	1.065 [27.05]	.975 [24.77]	.915 [23.24]	1.130 [28.70]

UNLESS OTHERWISE SPECIFIED, DIMENSIONS ARE IN INCHES. TOLERANCES ARE:  
DECIMALS ANGLES  
.XX: ±.01 [0.3] 2°  
.XXX: ±.005 [0.13]  
.XXXX: ±.0020 [0.051]

PROPRIETARY NOTE  
THIS DOCUMENT CONTAINS INFORMATION CONFIDENTIAL AND PROPRIETARY TO SAMTEC, INC. AND SHALL NOT BE REPRODUCED OR TRANSFERRED TO OTHER DOCUMENTS OR DISCLOSED TO OTHERS OR USED FOR ANY PURPOSE OTHER THAN THAT WHICH IT WAS OBTAINED WITHOUT THE EXPRESSED WRITTEN CONSENT OF SAMTEC, INC.

MATERIAL: DO NOT SCALE DRAWING SHEET SCALE: 2:1  
INSULATOR: LCP, UL 94 V0, COLOR: BLACK  
TERMINAL: PHOS BRONZE

**samtec**  
520 PARK EAST BLVD, NEW ALBANY, IN 47150  
PHONE: 812-944-6733 FAX: 812-948-5047  
e-Mail info@SAMTEC.com code 55322

DESCRIPTION:  
HW BOARD TO BOARD ASSEMBLY

DWG. NO.  
HW-XX-XX-XX-X-XXXX-SM-X-XXX

BY: G PURVIS 03/12/1993 SHEET 1 OF 2

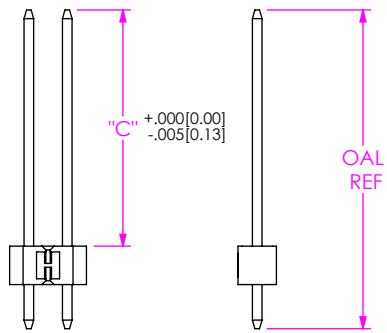

IN-PROCESS

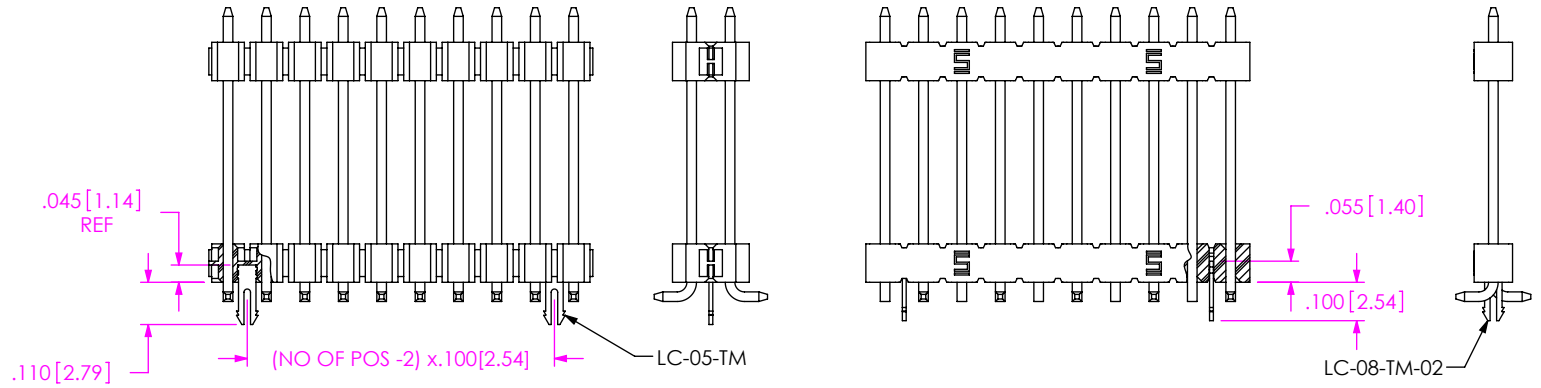

-D: DOUBLE ROW

FIG 2  
-LC: LOCKING CLIP  
(SAME AS FIG 1, DIFFERENT AS SHOWN)

-S: SINGLE ROW

CRITICAL DIMENSION INSPECTION INSTRUCTION TABLE

ASSEMBLY OPERATION	IN-PROCESS INSPECTION
FILL TOP BODY	C1
FORM	C2

TABLE 2

ROW OPTION	PACKAGING TUBE (SEE NOTE 2)	PLUG
-S: SINGLE	PT-1-24-01-47	TP-24
-D: DOUBLE	PT-1-24-02-47	TP-03
-LEAD STYLE -20 DOUBLE	PT-1-24-03-47	TP-03
-LEAD STYLE -20 SINGLE	PT-1-24-08-03	TP-07

FIG 4  
PACKAGING VIEW  
(TUBE PLUG LOCATED AS SHOWN)

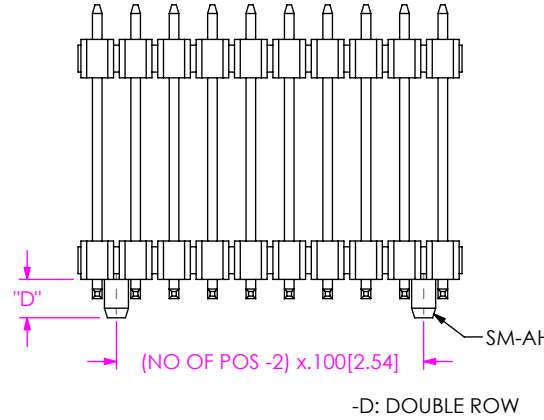
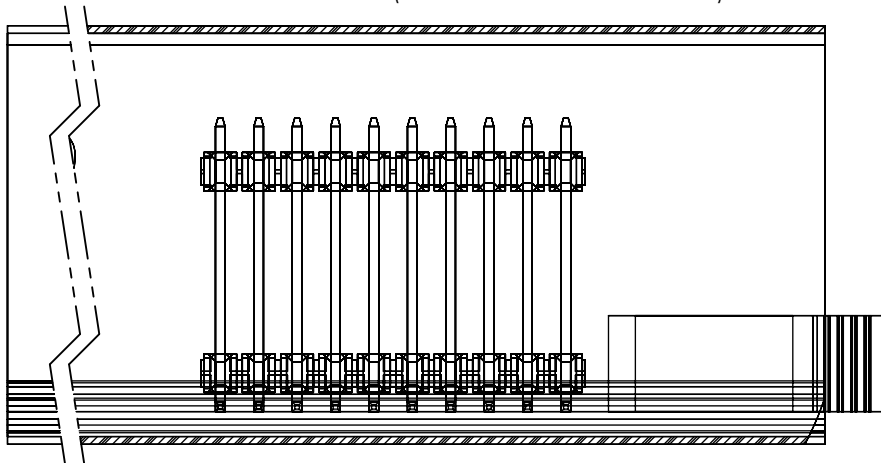

-D: DOUBLE ROW

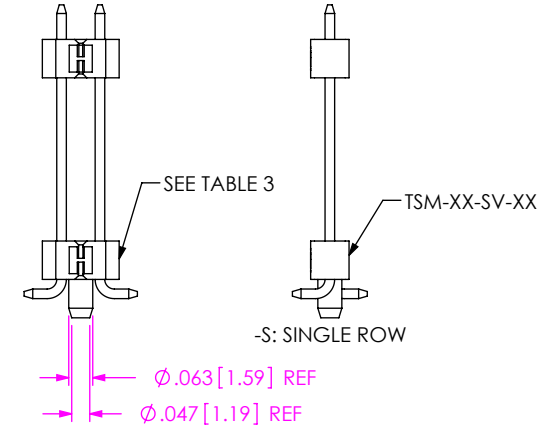

-S: SINGLE ROW

FIG 3  
-A: ALIGNMENT PIN  
(SAME AS FIG 1, DIFFERENT AS SHOWN)  
(2 POS USE 1 PER STRIP, 3-36 POS USE 2 PER STRIP)

TABLE 3		
	"D"	BODY
MOLDED	.100[2.54] REF	RTSN-50-DVU-XX TSM-XX-SV-XX
STAKED	.100[2.54] ±.005[0.13]	RTSM-50-DVU

PROPRIETARY NOTE  
THIS DOCUMENT CONTAINS INFORMATION CONFIDENTIAL AND PROPRIETARY TO SAMTEC, INC. AND SHALL NOT BE REPRODUCED OR TRANSFERRED TO OTHER DOCUMENTS OR DISCLOSED TO OTHERS OR USED FOR ANY PURPOSE OTHER THAN THAT WHICH IT WAS OBTAINED WITHOUT THE EXPRESSED WRITTEN CONSENT OF SAMTEC, INC.

DO NOT SCALE DRAWING

SHEET SCALE: 2:1



520 PARK EAST BLVD, NEW ALBANY, IN 47150  
PHONE: 812-944-6733 FAX: 812-948-5047  
e-Mail info@SAMTEC.com code 55322

DESCRIPTION:  
HW BOARD TO BOARD ASSEMBLY

DWG. NO.  
HW-XX-XX-XX-X-XXXX-SM-X-XXX

BY: G PURVIS 03/12/1993 SHEET 2 OF 2