



Features

- 1.8V to 3.5V Supply Voltage
- DC to AC Conversion
- Adjustable Output Frequency
- Adjustable Switch Frequency
- Output Voltage Regulation
- Enable/Disable Function
- Split Power Supply Capability
- < 100nA Shutdown Current

Applications

- Mobile Cellular Phones
- Pagers
- Portable Transceivers
- Remote Control Units
- Calculators

Description

Clare's CPC6826 is an electroluminescent (EL) lamp driver that is designed for applications operating with an input supply voltage range of 1.8V to 3.5V. The CPC6826 can also be used in a split-supply configuration, which enables the designer to specify operation with an input voltage as low as 1.5V.

Only five passive, external components are required: an inductor, a capacitor, and a diode to complete the boost switcher circuit; and two resistors to set the frequency of the two internal oscillators. These few components and the CPC6826 together generate the typical 170V_{P-P} AC signal required to drive an EL lamp.

The configuration of the CPC6826, with designer access to important components, allows maximum design flexibility for optimal efficiency and brightness.

Ordering Information

Part	Description
CPC6826U	MSOP-8

Figure 1. CPC6826 Block Diagram

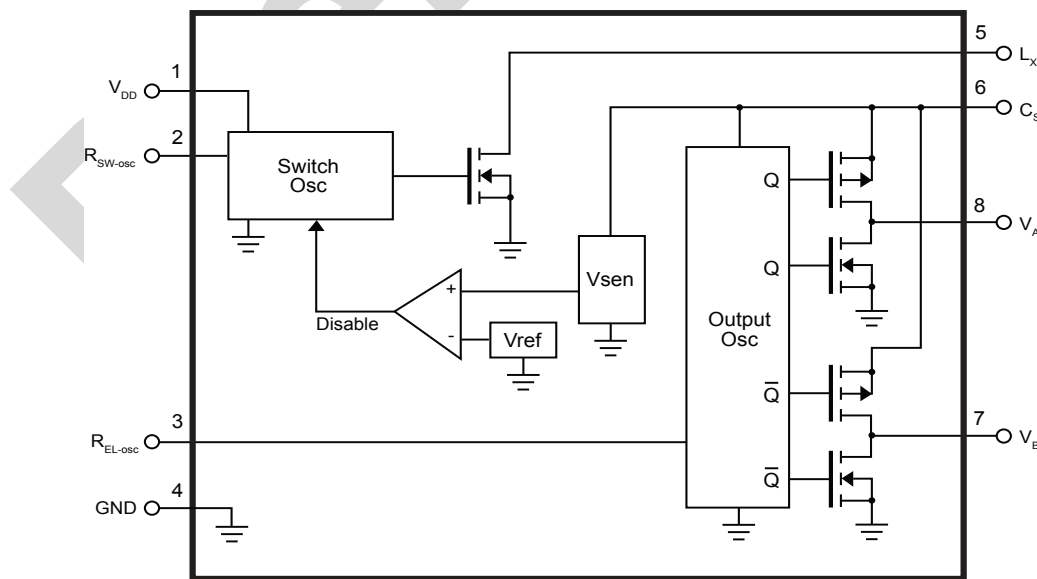

Features	1
Applications	1
Description	1
Ordering Information	1
1. Specifications	3
1.1 Package Pinout	3
1.2 Pin Description	3
1.3 Absolute Maximum Ratings	3
1.4 Recommended Operating Conditions	3
1.5 Electrical Characteristics	4
1.6 Enable/Disable Specifications	4
2. Typical Application A	5
2.1 Typical Application A Performance	5
2.2 Typical Application A Performance Charts	6
3. Typical Application B	7
3.1 Typical Application B Performance	7
3.2 Typical Application B Performance Charts	8
4. Functional Description	9
4.1 Overview	9
4.2 Regulation	9
4.3 Switch Oscillator Frequency	10
4.4 Switcher Duty Cycle	10
4.5 Output Oscillator Frequency	11
4.6 Enable/Disable Function	11
5. External Component Description	11
5.1 Diode	11
5.2 Output Capacitor	11
5.3 Inductor	11
5.4 REL Resistor	11
5.5 RSW Resistor	11
6. Manufacturing Information	12
6.1 Soldering	12
6.2 Washing	12

1. Specifications

1.1 Package Pinout

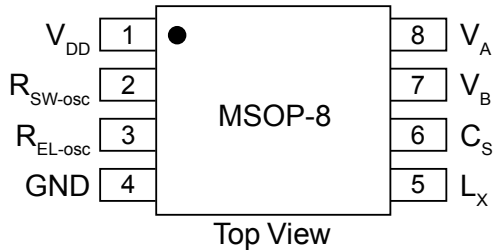

1.2 Pin Description

Pin	Name	Description
1	V_{DD}	Input Supply Voltage: 1.8V to 3.5V
2	R_{SW-osc}	External Switch Resistor: Set switch frequency of the internal power MOSFET by connecting an external resistor to V_{DD} . Connecting the external resistor to GND disables the switch oscillator and shuts down the device.
3	R_{EL-osc}	External EL Resistor: Set EL frequency of the internal H-bridge driver by connecting an external resistor to V_{DD} . Connecting the external resistor to GND disables the EL oscillator.
4	GND	Ground Return
5	L_X	Internal Switch Node: Internal high-voltage power MOSFET drain
6	C_S	Regulated Boost Output: Connect to the output of external storage capacitor of the boost regulator and connect to the cathode of the diode
7	V_B	EL Output: Connect to EL lamp - Polarity does not matter
8	V_A	EL Output: Connect to EL lamp - Polarity does not matter

1.3 Absolute Maximum Ratings

Parameter	Ratings	Units
Supply Voltage, V_{DD}	-0.5 to +4.5	V
Output Voltage, V_{CS}	-0.5 to +100	V
Power Dissipation	250	mW
Operating Temperature Range	-40 to +85	°C
Storage Temperature Range	-65 to +150	°C

1.4 Recommended Operating Conditions

Parameter	Symbol	Min	Typ	Max	Units
Supply Voltage	V_{DD}	1.8	-	3.5	V
Output Drive Frequency	f_{EL}	60	-	1000	Hz
Operating Temperature	T_A	-40	-	85	°C

1.5 Electrical Characteristics

Parameter	Conditions	Symbol	Min	Typ	Max	Units
DC Characteristics (Over recommended operating conditions unless otherwise specified, $T_A=25^\circ\text{C}$)						
On-Resistance of Switching Transistor	$I=100\text{mA}$	$R_{DS(on)}$	-	-	6	Ω
Output Regulation Voltage	$V_{DD}=1.8\text{V to }3.5\text{V}$	V_{CS}	80	85	90	V
Output Voltage Across Lamp	$V_{DD}=1.8\text{V to }3.5\text{V}$	V_{A-B}	-	170	-	V
Supply Current Quiescent	$R_{SW-osc} = \text{Low}$	I_{DDQ}	-	-	100	nA
Active	$V_{DD}=1.8\text{V to }3.5\text{V (Fig. 1)}$	I_{DD}	-	-	200	μA
Electrical Characteristics - Typical Split-Supply Application Circuit (Figure 1)						
Inductor Current	$V_{IN}=1.5\text{V (Fig. 1)}$	I_{IN}	-	26.65	45	mA
Output Voltage		V_{CS}	-	56	-	V
Switcher Frequency		f_{SW}	-	79.6	-	kHz
Switcher Duty Cycle		D	-	88	-	%
Output Drive Frequency		f_{EL}	300	348	450	Hz

1.6 Enable/Disable Specifications

Parameter	Conditions	Symbol	Min	Typ	Max	Units
Disable	$V_{DD}=1.8\text{V to }3.5\text{V}$	EN_L	0	-	0.5	V
Enable		EN_H	$V_{DD}-0.5$	-	V_{DD}	V

2. Typical Application A

Figure 1. Typical Application A Circuit Diagram

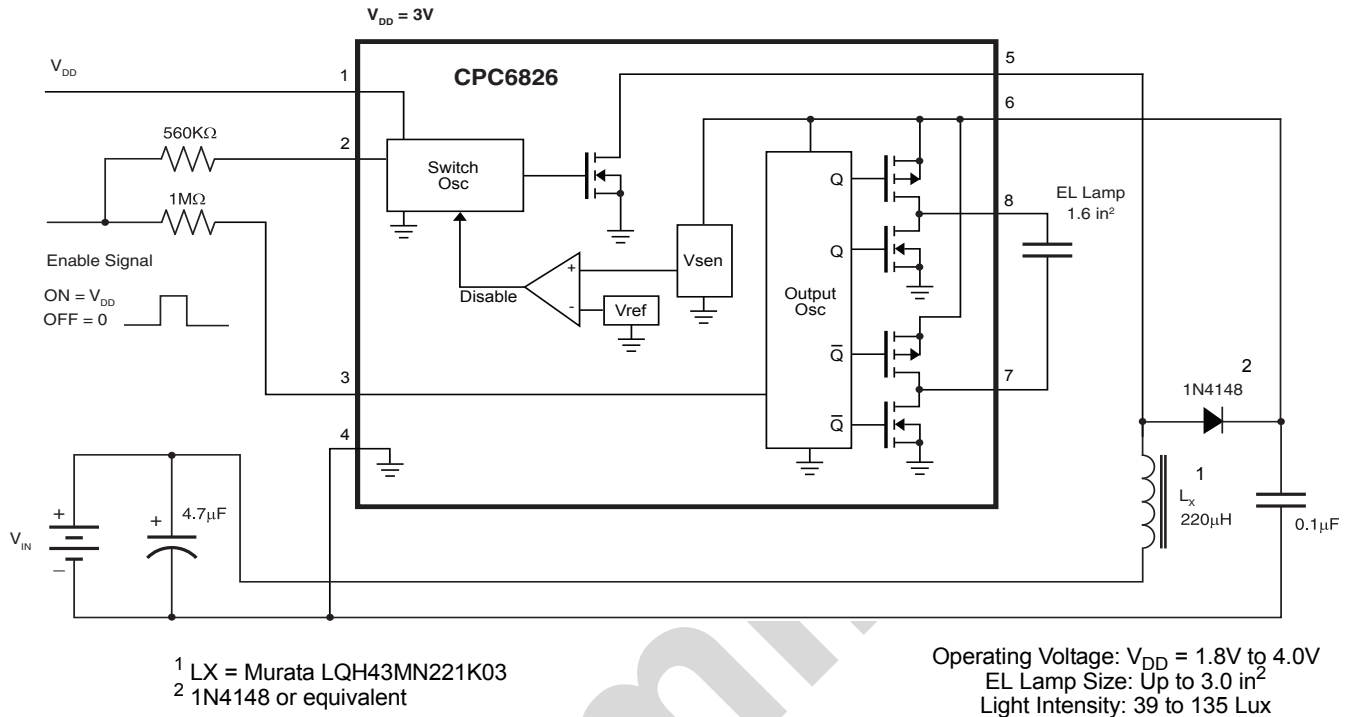

2.1 Typical Application A Performance

Device	Lamp Size	V_{IN}	I_{IN}	V_{CS}	f_{sw}	f_{EL}	Brightness	T_A
CPC6826	1.6 in^2	1.5V	26.65mA	56V	79.6KHz	348Hz	Lux 39	-40°C to $+85^\circ\text{C}$

Figure 2. Typical EL Output Waveform 348Hz

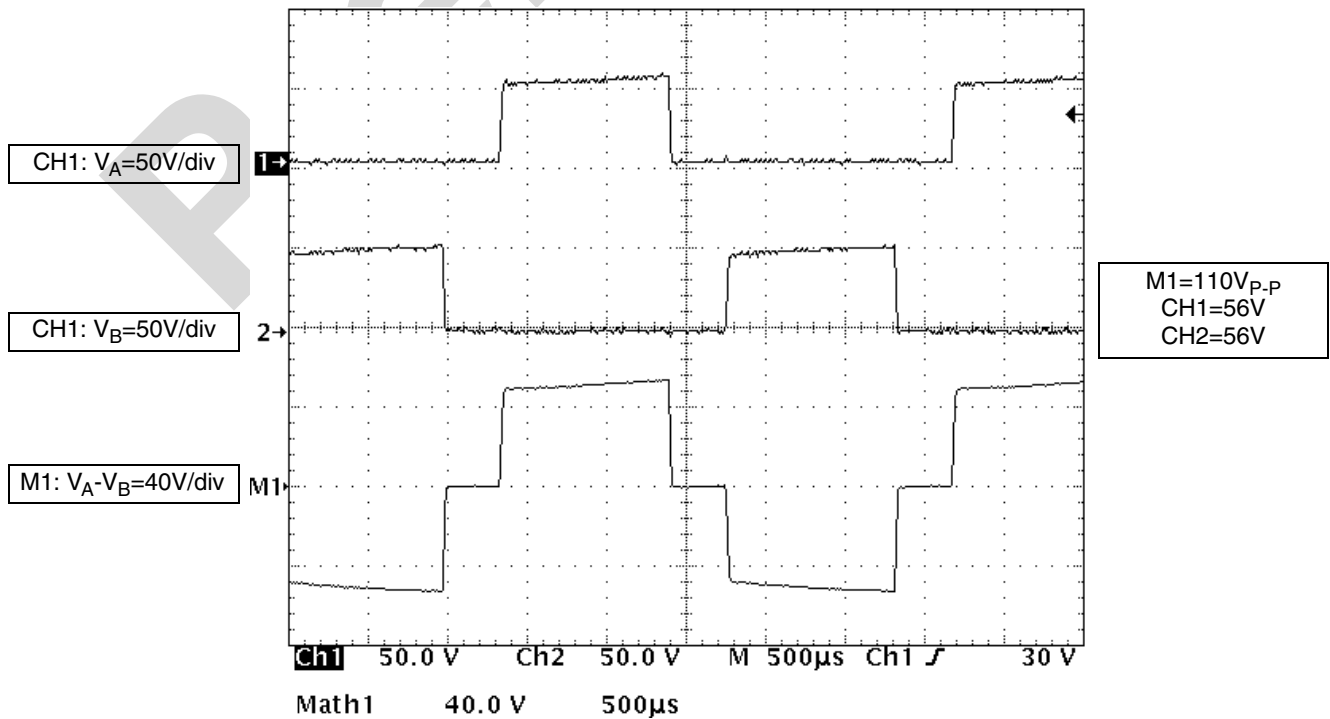

2.2 Typical Application A Performance Charts

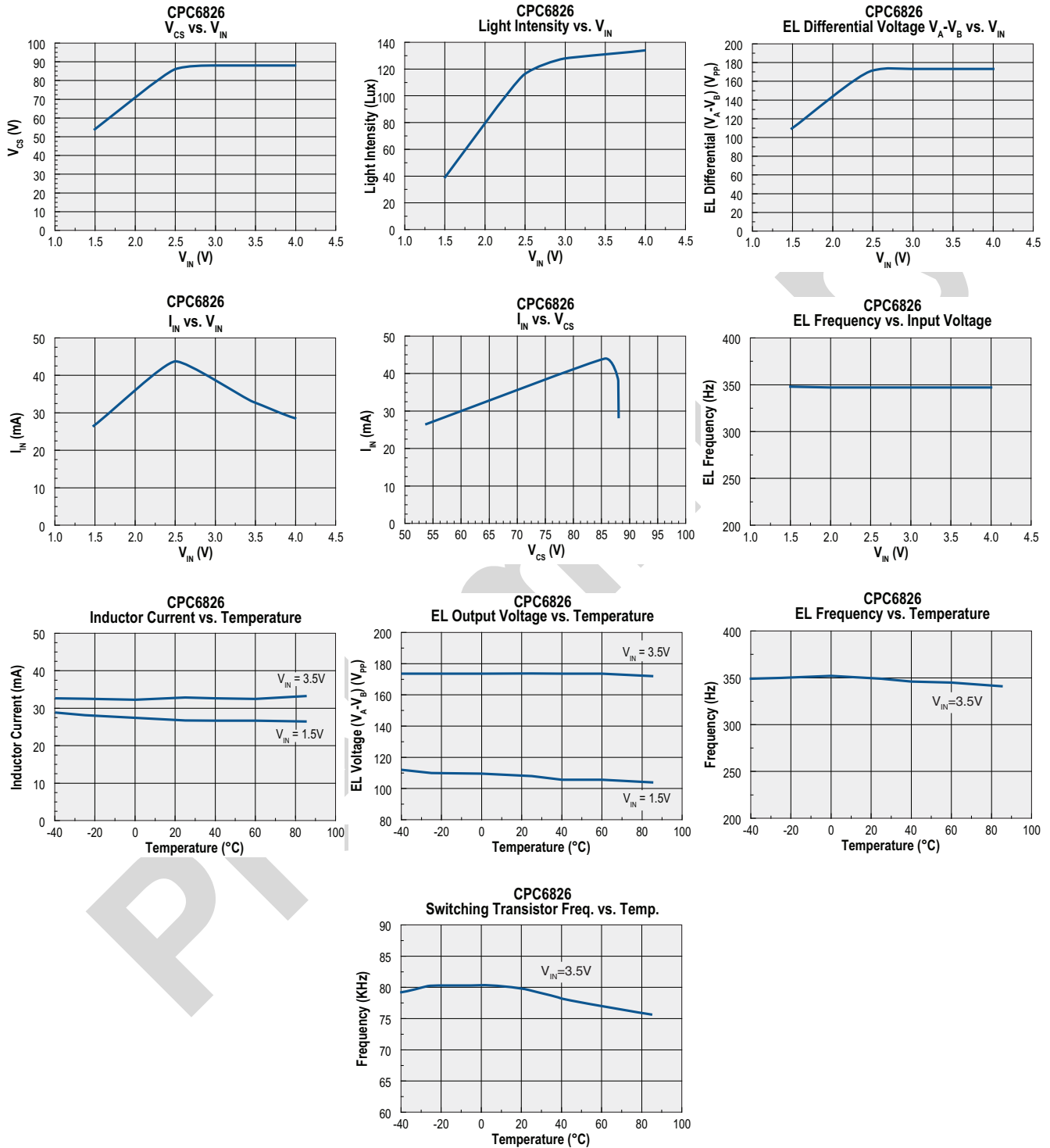

3. Typical Application B

Figure 3. Typical Application B Circuit Diagram

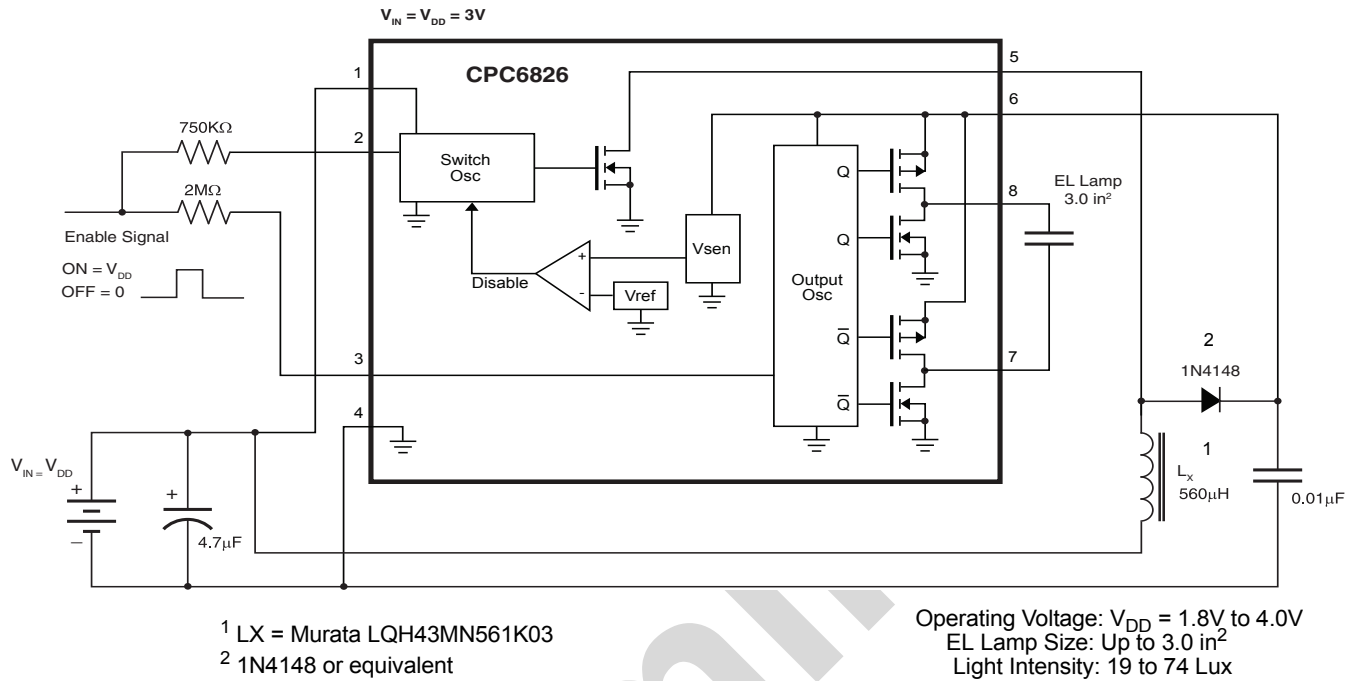

3.1 Typical Application B Performance

Device	Lamp Size	V_{DD}	I_{DD}	V_{CS}	f_{sw}	f_{EL}	Light Intensity	T_A
CPC6826	3.0 in^2	3.0V	27mA	84V	62KHz	180Hz	58 Lux	-40°C to $+85^\circ\text{C}$

Figure 4. Typical EL Output Waveform 180Hz

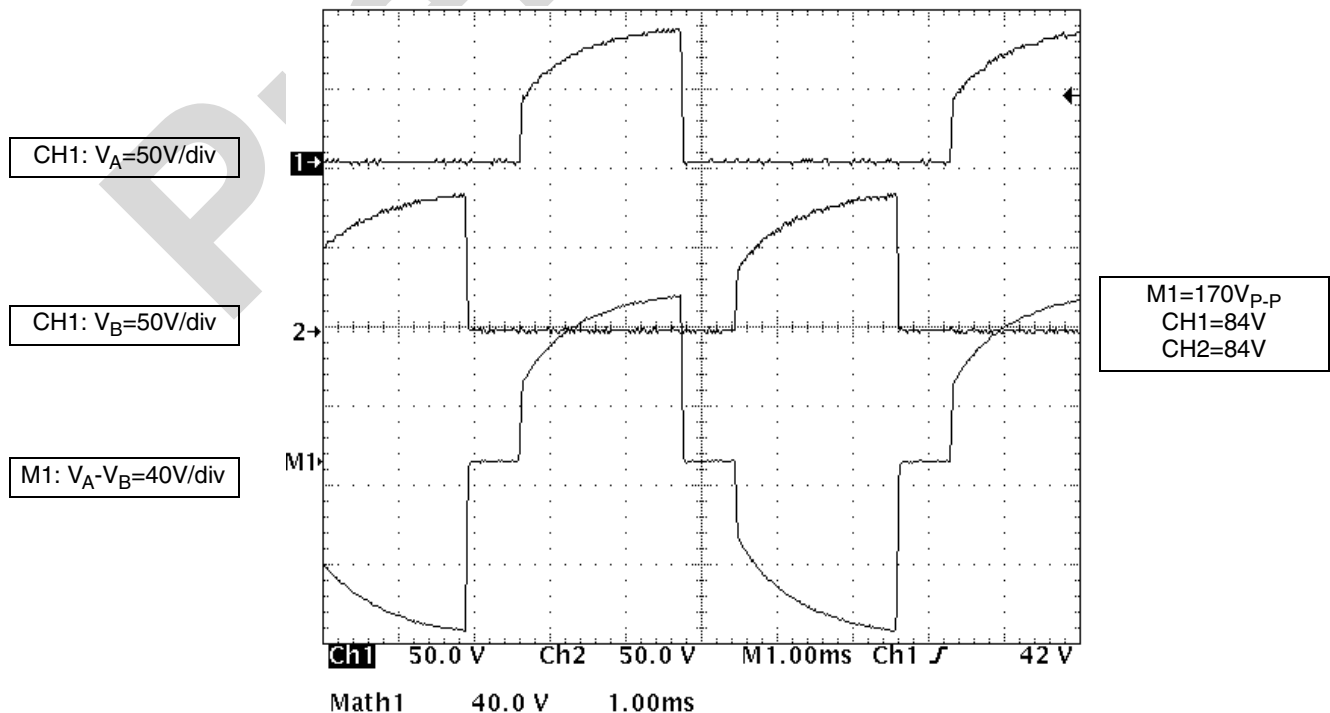

3.2 Typical Application B Performance Charts

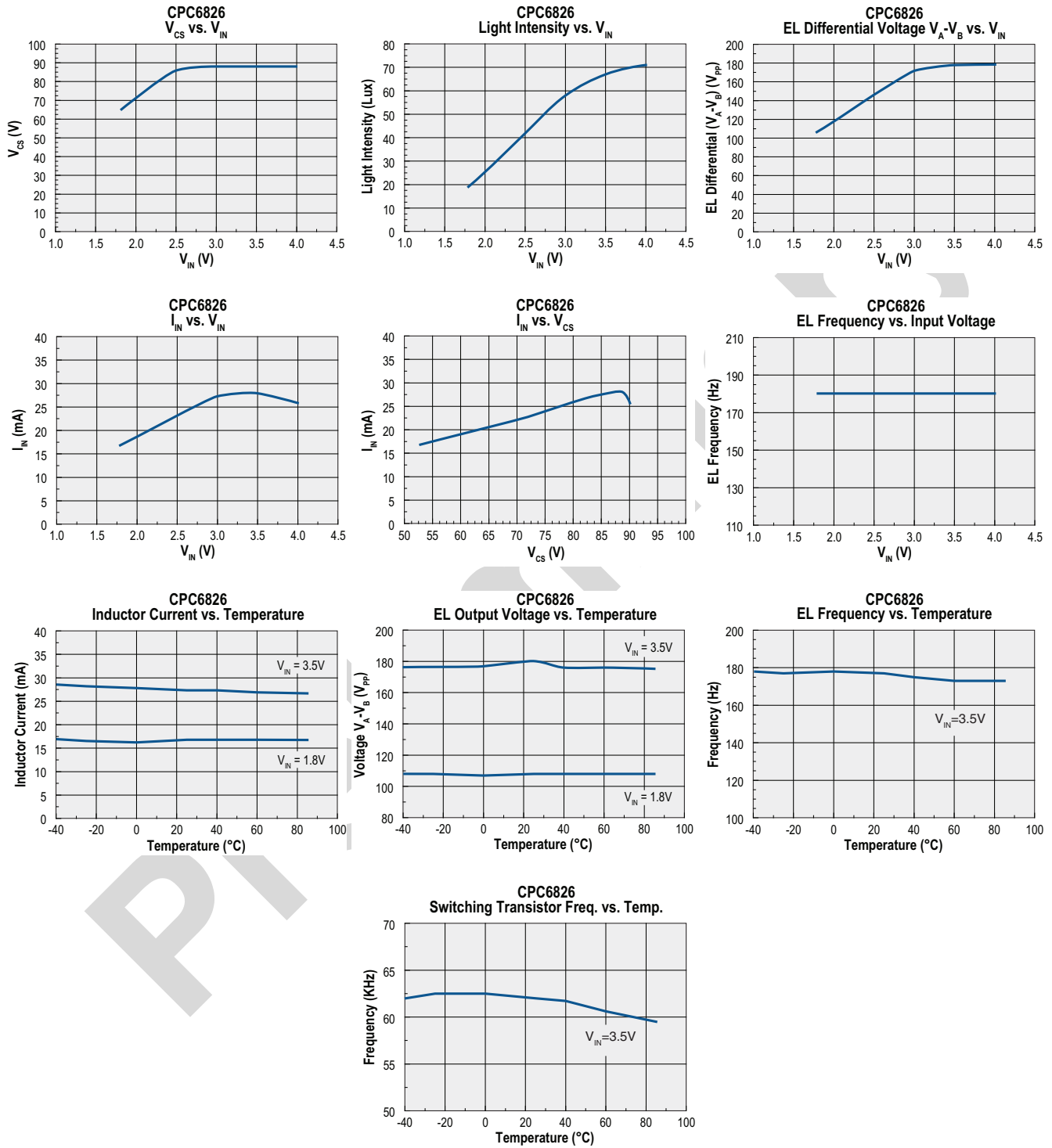

4. Functional Description

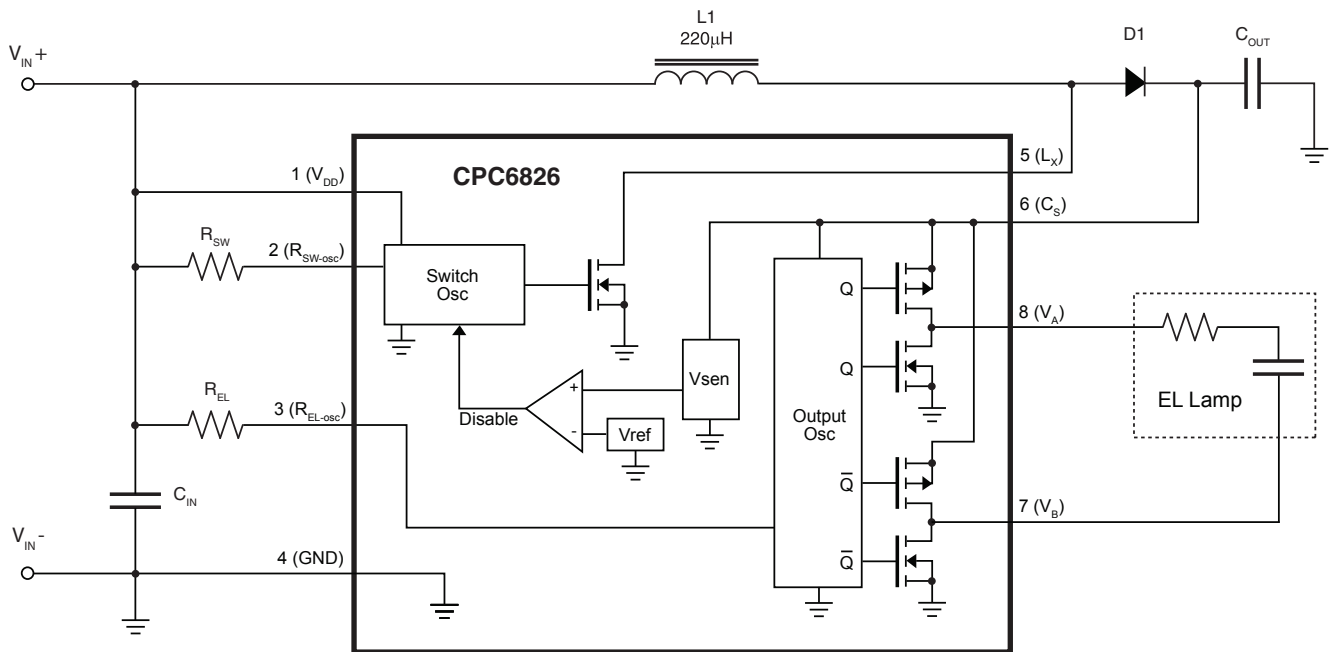

4.1 Overview

The CPC6826 is an EL lamp driver designed for battery applications operating from an input supply voltage range of 1.8V to 3.5V and generating an AC output voltage of 180V_{p-p}. The device is capable of driving lamp panels ranging from 1 in² to 5 in².

The CPC6826 IC main block architecture is made up of two independent oscillators, which control the switching of a power MOSFET and an H-bridge. Adjustment of two external resistors, R_{SW} and R_{EL}, sets the frequencies of the oscillators, thus allowing the designer to maximize efficiency and to increase the brightness of the lamp.

To conserve supply power and extend battery life, the CPC6826 automatically shuts down the switcher circuit whenever switcher output power exceeds load requirements. Supply power can also be conserved manually by disabling the switching circuit: pull pin 2, R_{SW}, to ground.

4.2 Regulation

The circuit configuration is based on simple boost converter topology. This method provides excellent efficiency, minimizes loss of energy, and allows smaller components to be used in the design. Only a few passive components (an inductor, a capacitor, two resistors, and a diode) are required to complete the simple boost switcher circuit.

When power is applied to V_{DD}, the internal feedback voltage V_{SEN} is less than V_{REF} causing the comparator output to go low, which enables the switching power MOSFET oscillator. When turned on, the internal low impedance switching MOSFET causes current to flow through the external inductor. With current flowing in the inductor, the switching MOSFET is turned off causing a flyback voltage to develop across the inductor. As the inductor's flyback voltage increases to a level greater than a diode drop above the voltage across the capacitor on the C_S pin, charge stored in the inductor is transferred into the C_{OUT} capacitor. This operating cycle continues until the V_{SEN} voltage is above the V_{REF} in which case the comparator disables the Switch Oscillator.

The internal high voltage H-Bridge section is enabled by external resistor R_{EL} at pin 3 and V_{DD} on pin 1. The H-bridge operation is controlled by output oscillator waveforms driving H-bridge high-side and low-side MOSFETs. Selecting the value of R_{EL} allows the designer to set the frequency of the internal oscillator to meet design requirements. By alternately switching the terminals of the lamp between high voltage supply and ground the 180V_{p-p} potential develops across the EL lamp.

CPC6826

4.3 Switch Oscillator Frequency

An external resistor connected between pin 2, R_{SW} , and pin 1, V_{DD} , controls the frequency of the Switch Oscillator. Switching frequency increases as the resistor value decreases. For resistor value selections, please refer to the typical characteristics graph:

Switching Frequency vs. Switch Resistor. Note that switch accuracy is $\pm 20\%$ due to the internal RC network.

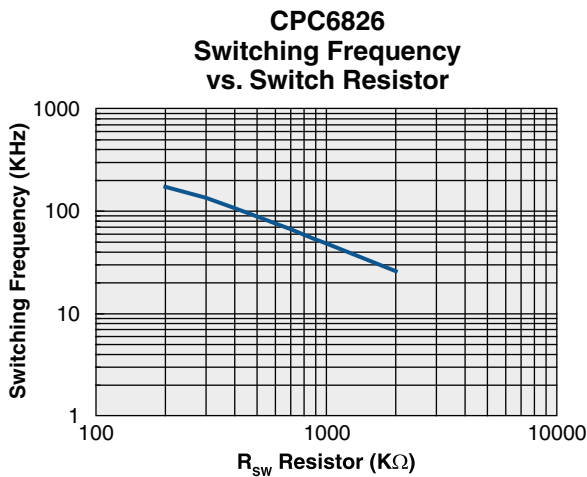

4.4 Switcher Duty Cycle

Clare's CPC6826 driver is designed to generate a fixed duty cycle with a nominal 88% on-time. In addition, this circuit generates an adjustable converter frequency via R_{SW} to turn on and off the high voltage power MOSFET. This drive method helps to eliminate RFI that can cause problems in portable wireless devices. The waveform on pin 5 (L_X) shows a typical switch oscillator frequency of 79.6KHz.

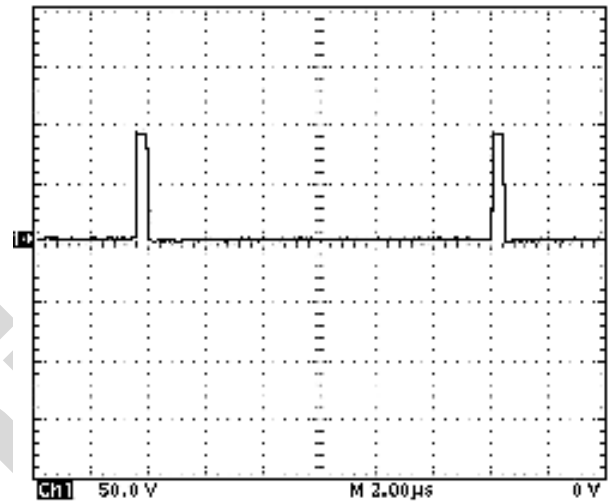

CH1: 50V/Div
Time: 2 μ s/Div
Frequency = 79.6KHz
 R_{SW} = 560K Ω
REL = 1M Ω
LX = 220 μ H
EL Lamp = 1.6 in2

4.5 Output Oscillator Frequency

Setting the output oscillator frequency is accomplished by connecting an external resistor between pin 3, R_{EL} , and pin 1, V_{DD} . The output oscillator frequency increases as the resistor value decreases. For resistor value selections refer to the typical characteristics graph: **Output Oscillator Frequency vs. R_{EL} Resistor**.

The switching frequency range is 60Hz to 1000Hz, with an accuracy of +/- 20%. Note that higher EL frequencies draw more current from the battery. In addition to this, the color of the EL lamp and the light intensity are also dependent on the frequency.

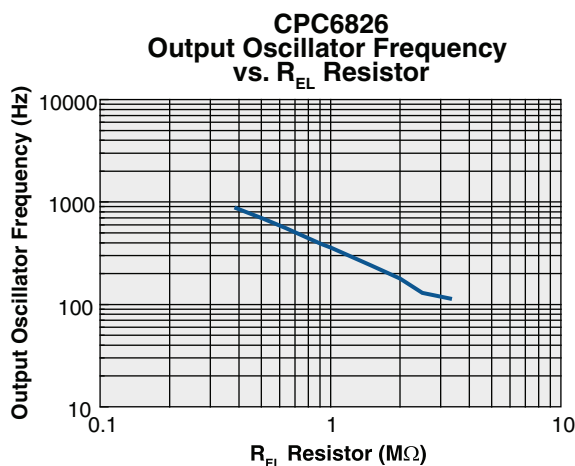

4.6 Enable/Disable Function

This function can be implemented to manually enable or disable the CPC6826. The enable function is accomplished by connecting resistor R_{SW} , on pin 2, and resistor R_{EL} , on pin 3, to V_{DD} pin 1. To disable the CPC6826, connect the two resistors to GND.

5. External Component Description

5.1 Diode

The application circuit lists fast-reverse-recovery diodes such as the 1SS400T1G in the SOD523 package, with a breakdown voltage of 100V and a forward current rating of 200mA. The typical voltage drop is 950mV at 25°C and the reverse recovery time, t_{RR} , is 4nS.

5.2 Output Capacitor

The value of the output capacitor, C_{OUT} , connected to pin 6, is based on the particular application circuit and is dependent on peak inductor current, inductor size, and the load. The application circuits give values

ranging from 0.01μF to 0.1μF with a working voltage of 100V. Ceramic capacitors come in 0805 or 1206 size with an X7R temperature coefficient. If the application requires higher stability over temperature, use a capacitor with a COG or NPO temperature coefficient.

5.3 Inductor

The inductor value depends on the specific application requirements. In general, inductor values for typical application circuits range from 100μH up to 1mH. The smaller value inductors are well suited to drive larger lamp sizes due to their inherent high current handling capability. Note that when inductor value decreases, the switching frequency controlled by R_{SW} should be increased to avoid inductor saturation.

A 220μH Murata (LQH43MN221K03) inductor with 5.4-Ohm series DC resistance, 110mA rated current, and +/- 10% tolerance is recommended. For inductors with the same value and lower series DC resistance, R_{SW} may have to be adjusted to avoid saturation.

Murata offers the LQH43 series from 100μH to 560μH in the 1812 package size.

5.4 R_{EL} Resistor

The EL lamp frequency is controlled via an external resistor connected from pin 3, R_{EL-OSC} , to pin 1, V_{DD} . The lamp frequency increases as the value of R_{EL} decreases. Higher EL frequency will increase the current that is drawn from the battery and will decrease the voltage at pin 6, V_{CS} . The color of the Lamp also depends on its frequency. The size of the resistor used in the application is 0603 with a tolerance of 1%. Smaller size resistors can be used to reduce board space consumed.

5.5 R_{SW} Resistor

The switching frequency of the converter is set by adjusting the value of resistor, R_{SW} , which is connected between pin 2 and pin 1, V_{DD} . The switching frequency increases as R_{SW} decreases. Increasing the value of R_{SW} will decrease the switching frequency of the internal oscillator, which in turn decrease inductor current and V_{CS} voltage at pin 6. The size of the resistor used in the application is 0603 with a tolerance of 1%. Smaller size resistors can be used to reduce board space consumed.

6. Manufacturing Information

6.1 Soldering

For proper assembly, the component must be processed in accordance with the current revision of IPC/JEDEC standard J-STD-020. Failure to follow the recommended guidelines may cause permanent damage to the device resulting in impaired performance and/or a reduced lifetime expectancy.

6.2 Washing

Clare does not recommend ultrasonic cleaning or the use of chlorinated hydrocarbons.



Mechanical Dimensions

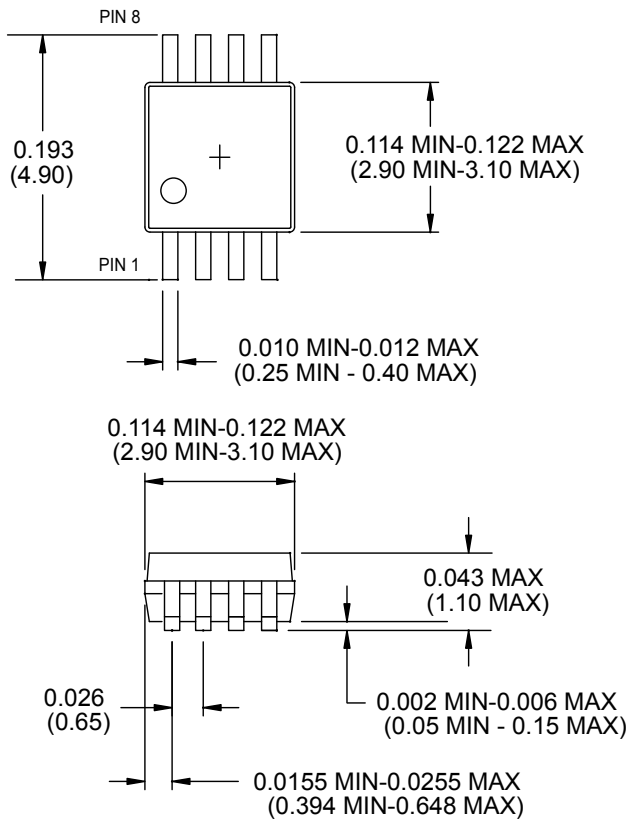

NOTES:
1. REFERENCE DRAWING JEDEC MO-187AA.

DIMENSIONS:
INCHES
(MM)

For additional information please visit our website at: www.clare.com

Clare, Inc. makes no representations or warranties with respect to the accuracy or completeness of the contents of this publication and reserves the right to make changes to specifications and product descriptions at any time without notice. Neither circuit patent licenses nor indemnity are expressed or implied. Except as set forth in Clare's Standard Terms and Conditions of Sale, Clare, Inc. assumes no liability whatsoever, and disclaims any express or implied warranty, relating to its products including, but not limited to, the implied warranty of merchantability, fitness for a particular purpose, or infringement of any intellectual property right.

The products described in this document are not designed, intended, authorized or warranted for use as components in systems intended for surgical implant into the body, or in other applications intended to support or sustain life, or where malfunction of Clare's product may result in direct physical harm, injury, or death to a person or severe property or environmental damage. Clare, Inc. reserves the right to discontinue or make changes to its products at any time without notice.

Specification: DS-CPC6826-R00C
©Copyright 2007, Clare, Inc.
All rights reserved. Printed in USA.
5/24/07