

High Luminous Efficacy  
Deep Red LED Emitter  
**LZ1-00R205**



### Key Features

- High Efficacy 5W Deep Red LED
- Ultra-small foot print – 4.4mm x 4.4mm x 3.2mm
- Surface mount ceramic package with integrated glass lens
- Very low Thermal Resistance (5.5°C/W)
- Very high Radiant Flux density
- New industry standard for Radiant Flux Maintenance (>90% at 100,000 Hours)
- Autoclave complaint (JEDEC JESD22-A102-C)
- JEDEC Level 2 for Moisture Sensitivity Level
- Lead (Pb) free and RoHS compliant
- Reflow solderable (up to 6 cycles)
- Emitter available on [Standard](#) or [Miniature](#) MCPCB (optional)

### Typical Applications

- Horticulture
- Photo Therapy
- Machine Vision

### Description

The LZ1-00R205 Deep Red LED emitter provides 5W power in an extremely small package. The LZ1-00R205 LED emitter provides superior radiometric power in the wavelength range specifically required for plants' chlorophyll *a* absorption. With a 4.4mm x 4.4mm x 3.2mm ultra-small footprint, this package provides exceptional radiant flux density. The patent-pending design has unparalleled thermal and optical performance. The high quality materials used in the package are chosen to optimize light output and minimize stresses which results in monumental reliability and lumen maintenance. The robust product design thrives in outdoor applications with high ambient temperatures and high humidity.

## Table of Contents

Product Nomenclature . . . . .	3
IPC/JEDEC Moisture Sensitivity . . . . .	3
Average Radiant Flux Maintenance Projections . . . . .	3
Radiant Flux Binning . . . . .	4
Peak Wavelength Binning . . . . .	4
Forward Voltage Binning . . . . .	4
Absolute Maximum Ratings . . . . .	5
Optical Characteristics . . . . .	5
Electrical Characteristics . . . . .	5
Mechanical Dimensions . . . . .	6
Pin-Out . . . . .	6
Recommended Solder Pad Layout . . . . .	6
Reflow Soldering Profile . . . . .	7
Typical Radiation Pattern . . . . .	7
Typical Relative Spectral Power Distribution . . . . .	8
Typical Peak Wavelength Shift over Temperature. . . . .	8
Typical Normalized Radiant Flux . . . . .	9
Typical Normalized Radiant Flux over Temperature . . . . .	9
Typical Forward Current Characteristics . . . . .	10
Current Derating Curves . . . . .	10
Emitter Tape & Reel Specifications . . . . .	11
Company Information . . . . .	12

## Product Nomenclature

The LZ Series part number designation is defined as follows:



Where:

- A – designates the number of LED die in the package (“1” for 5W)
- B – designates the package level (“0” for Emitter)
- C – designates the radiation pattern (“0” for Lambertian)
- D and E – designate the color (“R2” for Deep Red - 660nm Peak Wavelength)
- F and G – designate the Power (“05” for 5W typical rating)
- H – designates the Flux bin (See Table 2)
- J and K – designate the Wavelength bin (see Table 3)
- L – designates the V<sub>F</sub> bin (See Table 4)

Ordering information:

For ordering LedEngin products, please reference the base part number. The base part number represents any of the flux, dominant wavelength, or forward voltage bins specified in the binning tables below. For ordering products with special bin selections, please contact a LedEngin sales representative or authorized distributor.

## IPC/JEDEC Moisture Sensitivity Level

Table 1 - IPC/JEDEC J-STD-20 MSL Classification:

Level	Soak Requirements					
	Floor Life		Standard		Accelerated	
	Time	Conditions	Time (hrs)	Conditions	Time (hrs)	Conditions
2	1 Year	≤ 30°C/ 60% RH	168 +5/-0	85°C/ 60% RH	n/a	n/a

Notes for Table 1:

1. The standard soak time is the sum of the default value of 24 hours for the semiconductor manufacturer’s exposure time (MET) between bake and bag and the floor life of maximum time allowed out of the bag at the end user of distributor’s facility.

## Average Radiant Flux Maintenance Projections

Based on long-term WHTOL testing, LedEngin projects that the LZ Series will deliver, on average, 90% Radiant Flux Maintenance at 100,000 hours of operation at a forward current of 1000 mA. This projection is based on constant current operation with junction temperature maintained at or below 110°C.

## Radiant Flux Bins

Table 2:

Bin Code	Minimum Radiant Flux ( $\Phi$ ) @ $I_F = 1000\text{mA}$ <sup>[1,2]</sup> (mW)	Maximum Radiant Flux ( $\Phi$ ) @ $I_F = 1000\text{mA}$ <sup>[1,2]</sup> (mW)	Typical Radiant Flux ( $\Phi$ ) @ $I_F = 1500\text{mA}$ <sup>[2]</sup> (mW)
4	400	500	640
5	500	600	720

Notes for Table 2:

1. Radiant flux performance guaranteed within published operating conditions. LedEngin maintains a tolerance of  $\pm 10\%$  on flux measurements.
2. Future products will have even higher levels of radiant flux performance. Contact LedEngin Sales for updated information.

## Peak Wavelength Bin

Table 3:

Bin Code	Minimum Peak Wavelength ( $\lambda_P$ ) @ $I_F = 1000\text{mA}$ <sup>[1]</sup> (nm)	Maximum Peak Wavelength ( $\lambda_P$ ) @ $I_F = 1000\text{mA}$ <sup>[1]</sup> (nm)
0	655	670

Notes for Table 3:

1. LedEngin maintains a tolerance of  $\pm 2.0\text{nm}$  on peak wavelength measurements.

## Forward Voltage Bin

Table 4:

Bin Code	Minimum Forward Voltage ( $V_F$ ) @ $I_F = 1000\text{mA}$ <sup>[1]</sup> (V)	Maximum Forward Voltage ( $V_F$ ) @ $I_F = 1000\text{mA}$ <sup>[1]</sup> (V)
0	2.48	3.44

Notes for Table 4:

1. LedEngin maintains a tolerance of  $\pm 0.04\text{V}$  for forward voltage measurements.

## Absolute Maximum Ratings

Table 5:

Parameter	Symbol	Value	Unit
DC Forward Current <sup>[1]</sup>	$I_F$	1500	mA
Peak Pulsed Forward Current <sup>[2]</sup>	$I_{FP}$	2000	mA
Reverse Voltage	$V_R$	See Note 3	V
Storage Temperature	$T_{stg}$	-40 ~ +125	°C
Junction Temperature	$T_J$	125	°C
Soldering Temperature <sup>[4]</sup>	$T_{sol}$	260	°C
Allowable Reflow Cycles		6	
Autoclave Conditions <sup>[5]</sup>		121°C at 2 ATM, 100% RH for 168 hours	
ESD Sensitivity <sup>[6]</sup>		> 8,000 V HBM Class 3B JESD22-A114-D	

Notes for Table 5:

- Maximum DC forward current is determined by the overall thermal resistance and ambient temperature. Follow the curves in Figure 10 for current derating.
- Pulse forward current conditions: Pulse Width  $\leq$  10msec and Duty Cycle  $\leq$  10%.
- LEDs are not designed to be reverse biased.
- Solder conditions per JEDEC 020D. See Reflow Soldering Profile Figure 3.
- Autoclave Conditions per JEDEC JESD22-A102-C.
- LedEngin recommends taking reasonable precautions towards possible ESD damages and handling the LZ1-00R205 in an electrostatic protected area (EPA). An EPA may be adequately protected by ESD controls as outlined in ANSI/ESD S6.1.

## Optical Characteristics @ $T_C = 25^\circ\text{C}$

Table 6:

Parameter	Symbol	Typical	Unit
Radiant Flux (@ $I_F = 1000\text{mA}$ )	$\Phi$	525	mW
Radiant Flux (@ $I_F = 1500\text{mA}$ )	$\Phi$	685	mW
Peak Wavelength	$\lambda_P$	660	nm
Viewing Angle <sup>[1]</sup>	$2\Theta_{1/2}$	90	Degrees
Total Included Angle <sup>[2]</sup>	$\Theta_{0.9V}$	130	Degrees

Notes for Table 6:

- Viewing Angle is the off axis angle from emitter centerline where the radiant power is  $\frac{1}{2}$  of the peak value.
- Total Included Angle is the total angle that includes 90% of the total radiant flux.

## Electrical Characteristics @ $T_C = 25^\circ\text{C}$

Table 7:

Parameter	Symbol	Typical	Unit
Forward Voltage (@ $I_F = 1000\text{mA}$ )	$V_F$	2.8	V
Forward Voltage (@ $I_F = 1500\text{mA}$ )	$V_F$	3.1	V
Temperature Coefficient of Forward Voltage	$\Delta V_F / \Delta T_J$	-3.6	mV/°C
Thermal Resistance (Junction to Case)	$R\Theta_{J-C}$	5.5	°C/W

## Mechanical Dimensions (mm)

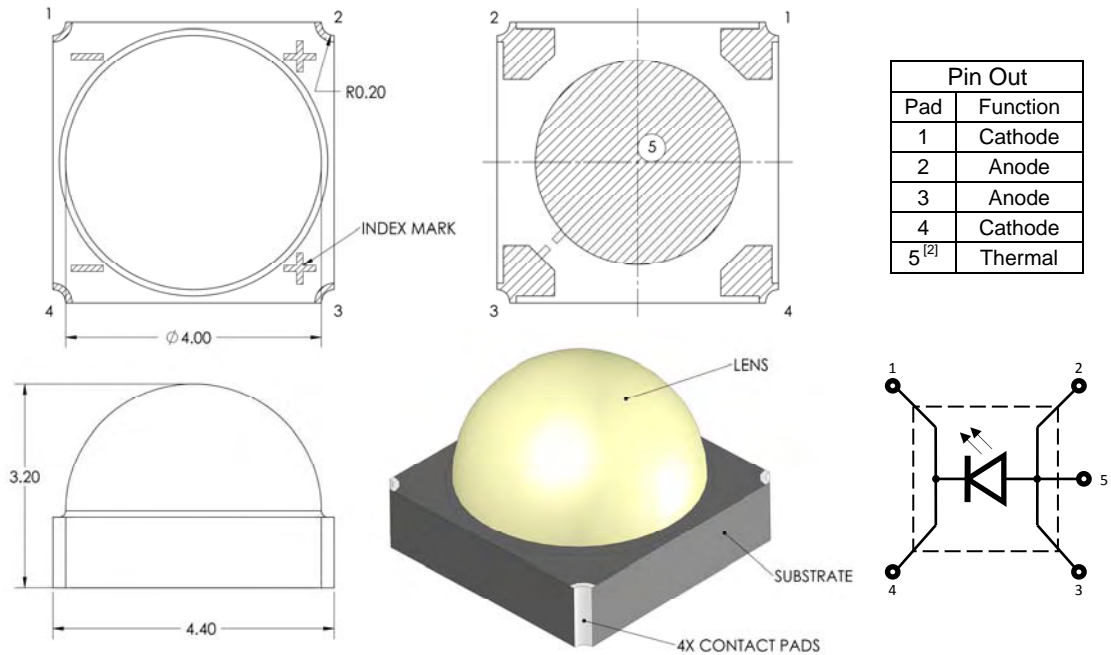

Figure 3: Package outline drawing.

### Notes for Figure 3:

1. Unless otherwise noted, the tolerance =  $\pm 0.20$  mm.
2. Thermal contact, Pad 5, is electrically connected to the Anode, Pads 2 and 3. Do not electrically connect any electrical pads to the thermal contact, Pad 5. LedEngin recommends mounting the LZ1-00R205 to a MCPCB that provides insulation between all electrical pads and the thermal contact, Pad 5. LedEngin offers [LZ1-10R205](#) and [LZ1-30R205](#) MCPCB options which provide both electrical and thermal contact insulation with low thermal resistance. Please refer to Application Note MCPCB Options 1 and 3, or contact a LedEngin sales representative for more information.

## Recommended Solder Pad Layout (mm)

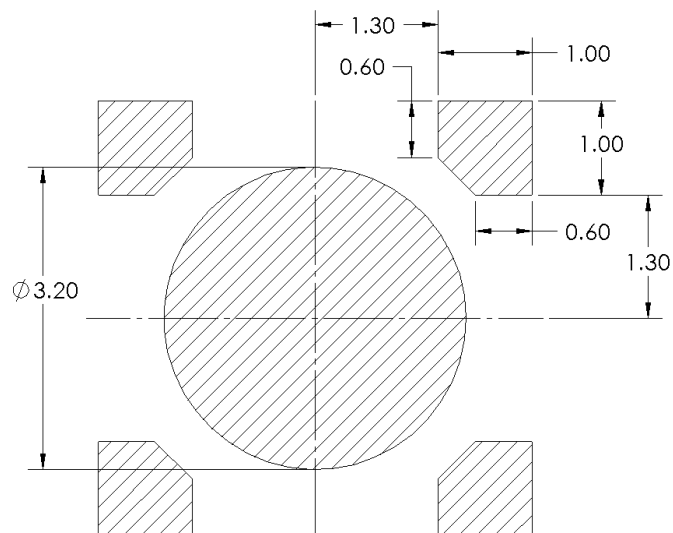

Figure 4: Recommended solder mask opening (hatched area) for anode, cathode, and thermal pad.

### Note for Figure 4:

1. Unless otherwise noted, the tolerance =  $\pm 0.20$  mm.

## Reflow Soldering Profile

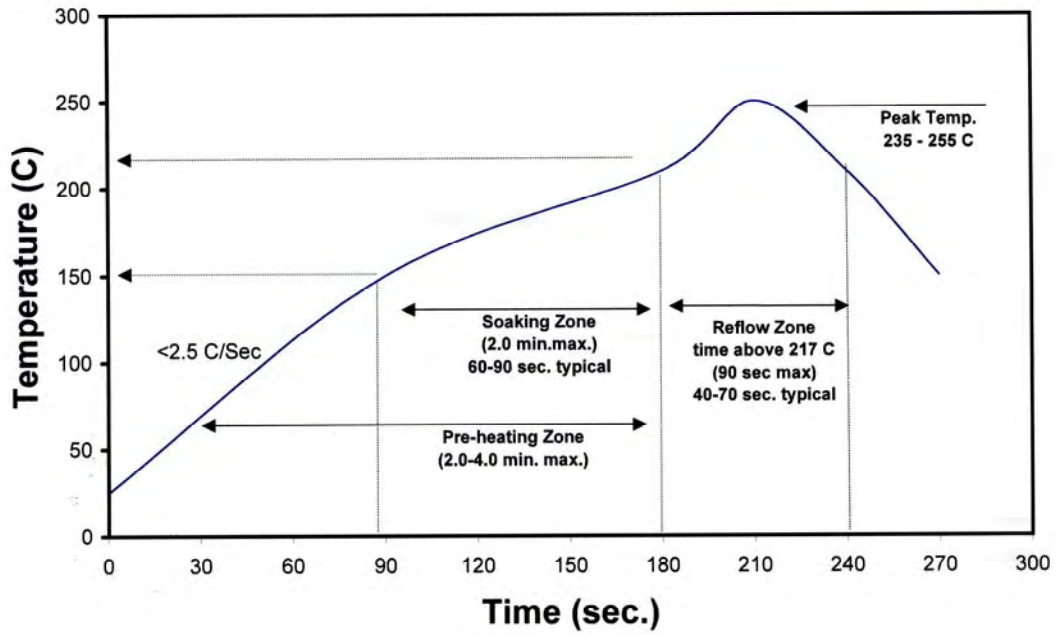

Figure 3: Reflow soldering profile for lead free soldering.

## Typical Radiation Pattern

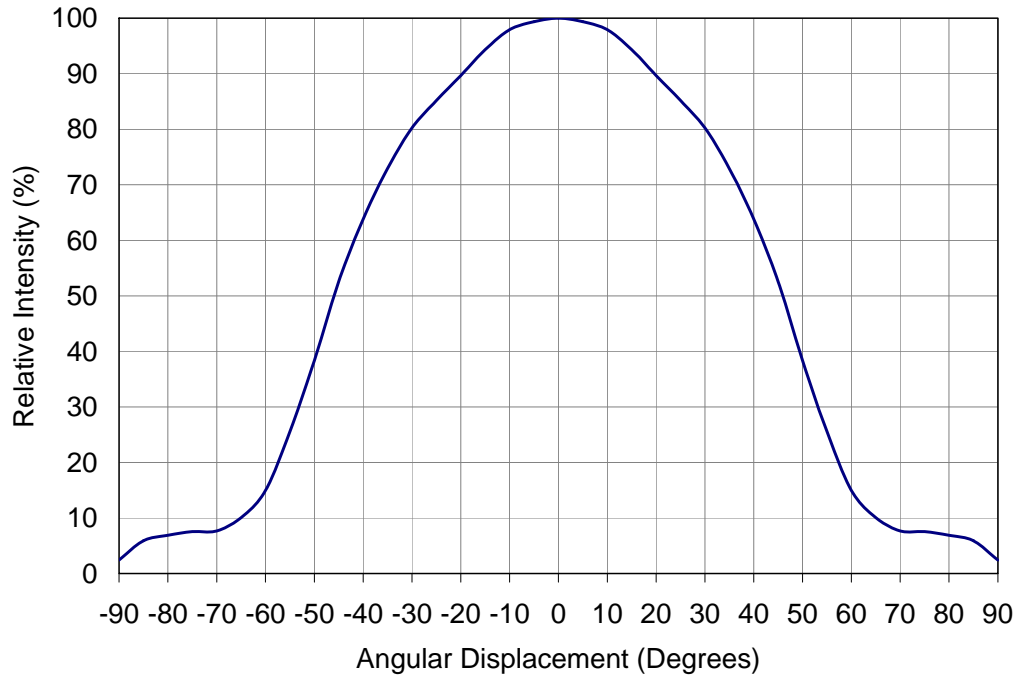

Figure 4: Typical representative spatial radiation pattern.

## Typical Relative Spectral Power Distribution

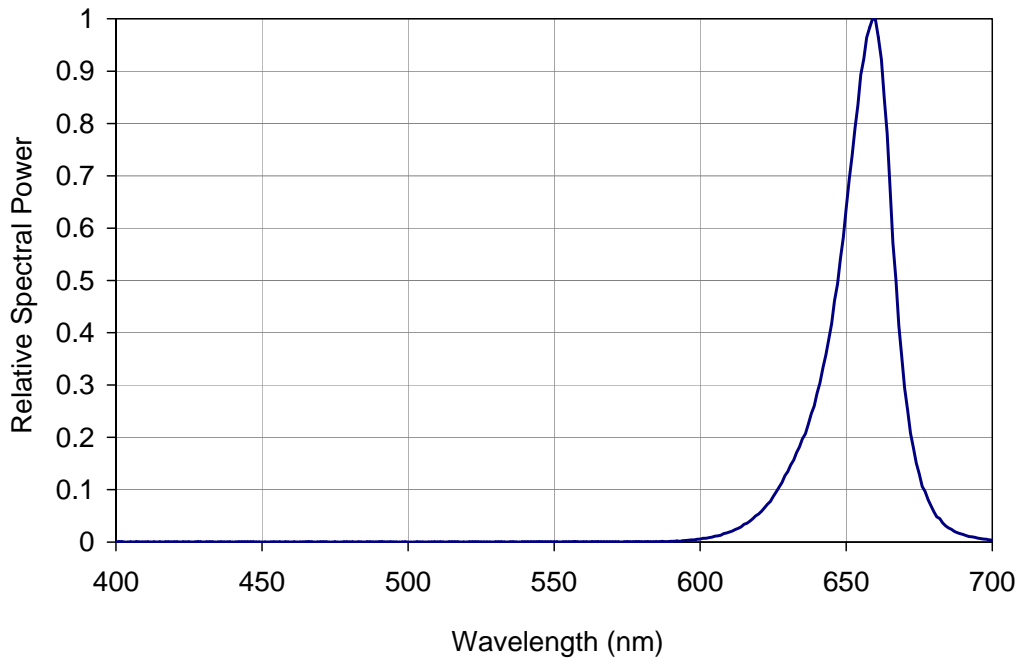

Figure 5: Relative spectral power vs. wavelength @  $T_c = 25^\circ\text{C}$ .

## Typical Peak Wavelength Shift over Temperature

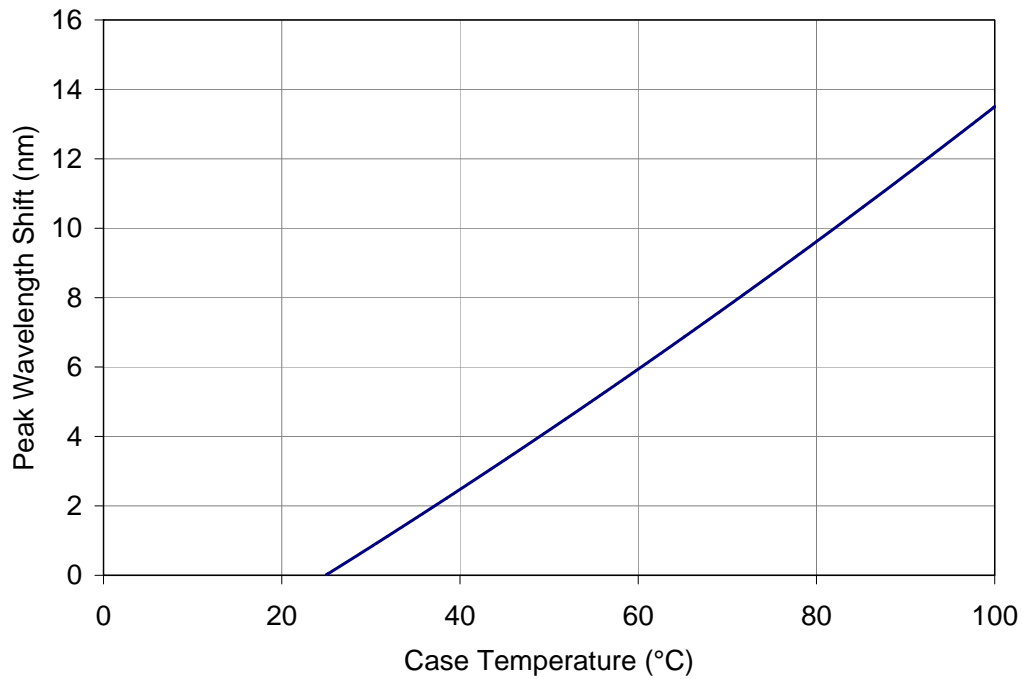

Figure 6: Typical peak wavelength shift vs. case temperature.



## Typical Normalized Radiant Flux

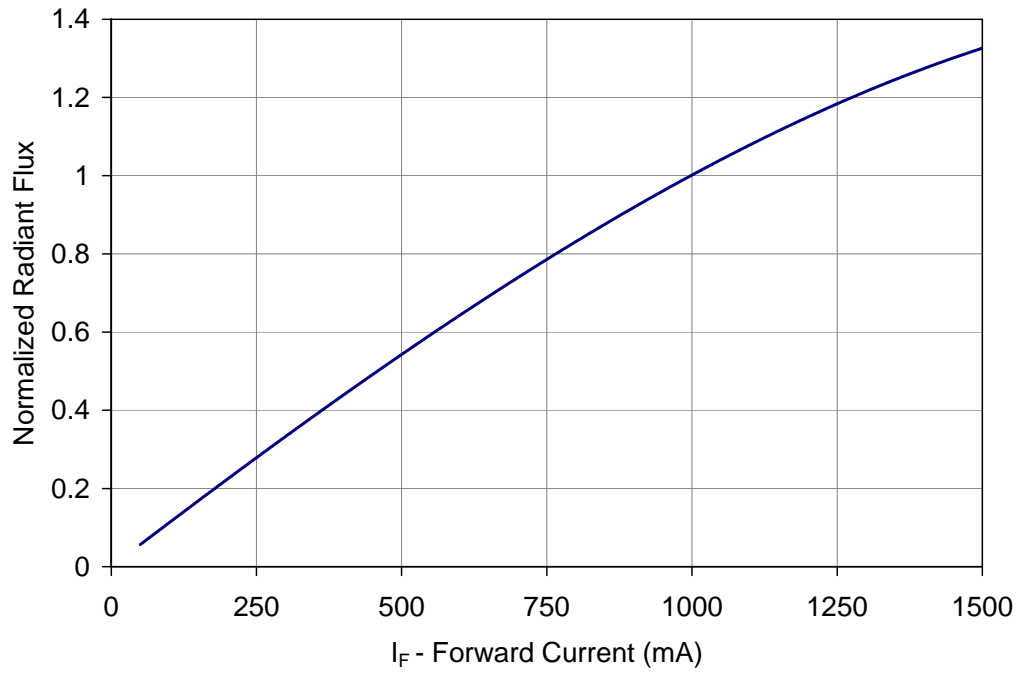

Figure 7: Typical normalized radiant flux vs. forward current @  $T_C = 25^\circ\text{C}$ .

## Typical Normalized Radiant Flux over Temperature

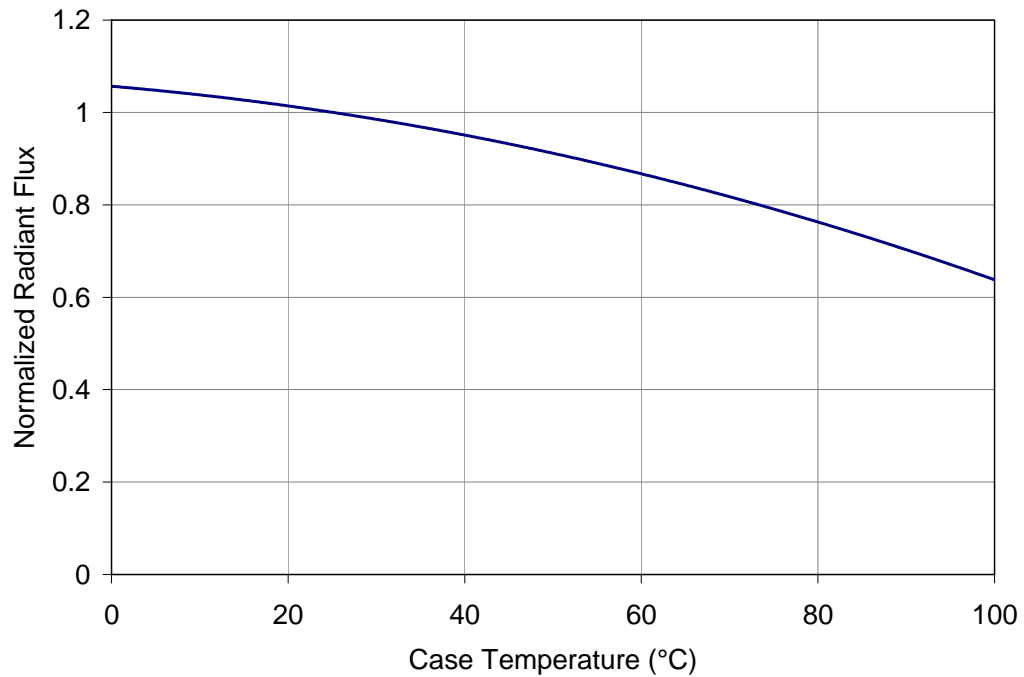

Figure 8: Typical normalized radiant flux vs. case temperature.

## Typical Forward Current Characteristics

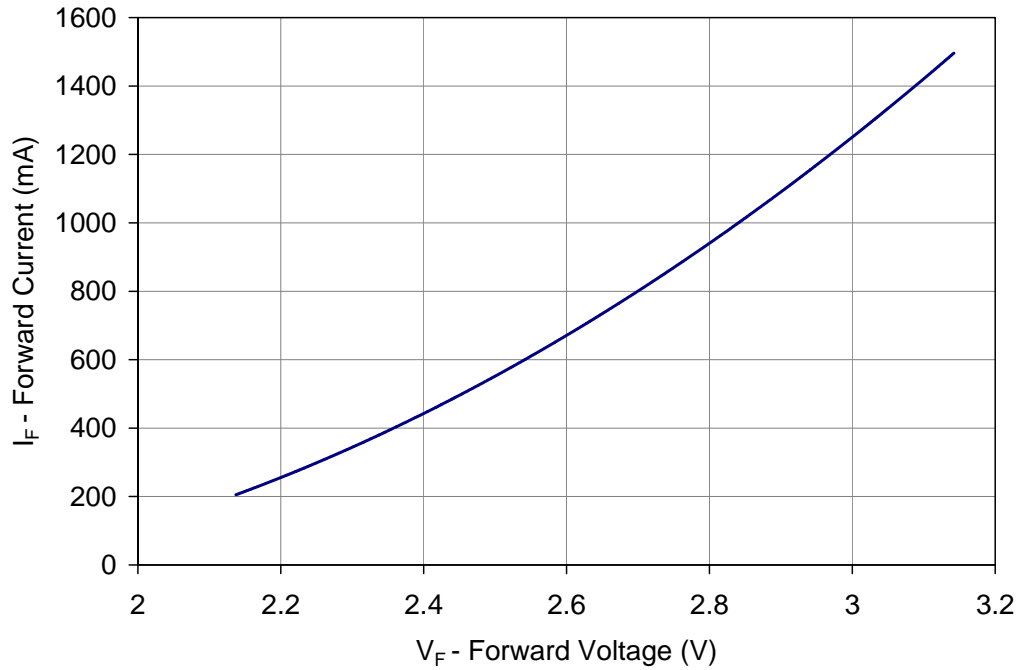

Figure 9: Typical forward current vs. forward voltage @  $T_C = 25^\circ\text{C}$ .

## Current Derating

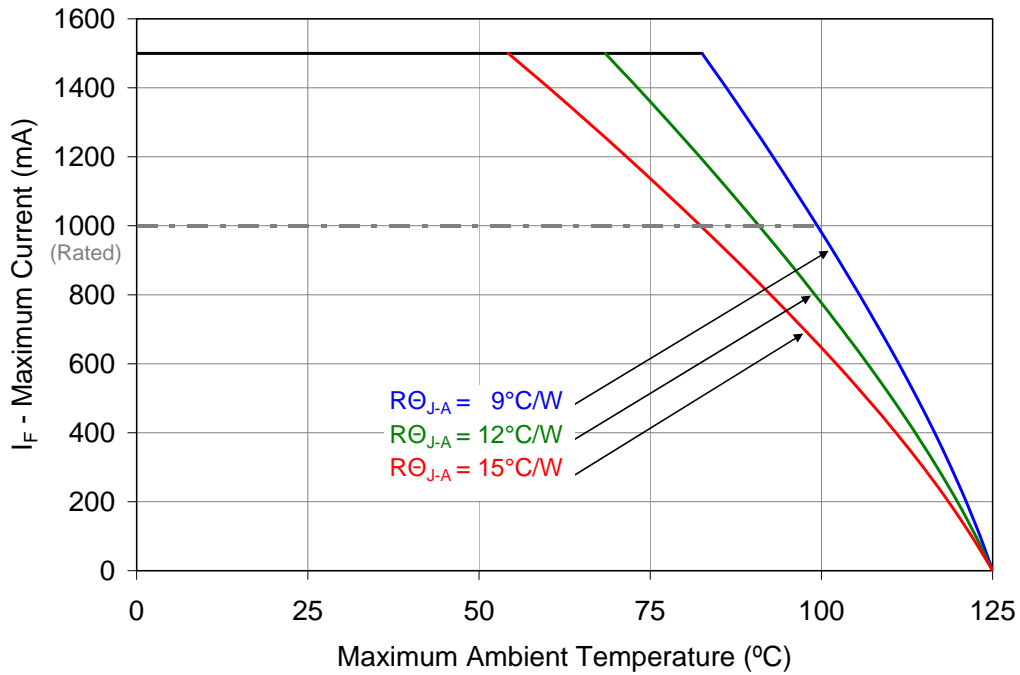

Figure 10: Maximum forward current vs. ambient temperature based on  $T_{J(\text{MAX})} = 125^\circ\text{C}$ .

Notes for Figure 10:

1.  $R\theta_{J-C}$  [Junction to Case Thermal Resistance] for the LZ1-00R205 is typically  $5.5^\circ\text{C/W}$ .
2.  $R\theta_{J-A}$  [Junction to Ambient Thermal Resistance] =  $R\theta_{J-C}$  +  $R\theta_{C-A}$  [Case to Ambient Thermal Resistance].

## Emitter Tape and Reel Specifications (mm)

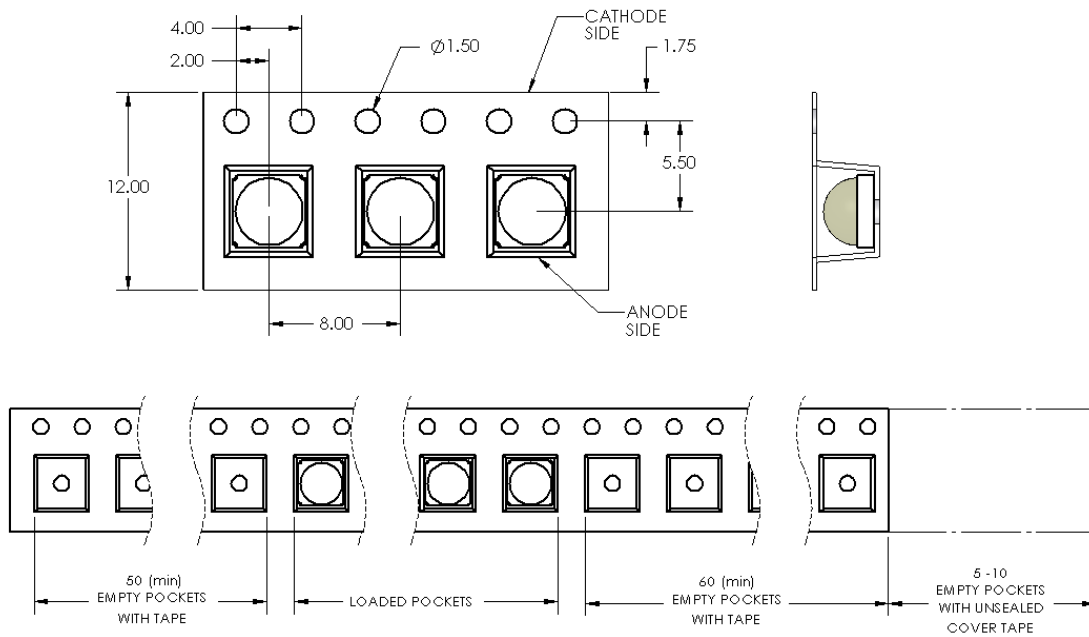

Figure 11: Emitter carrier tape specifications (mm).

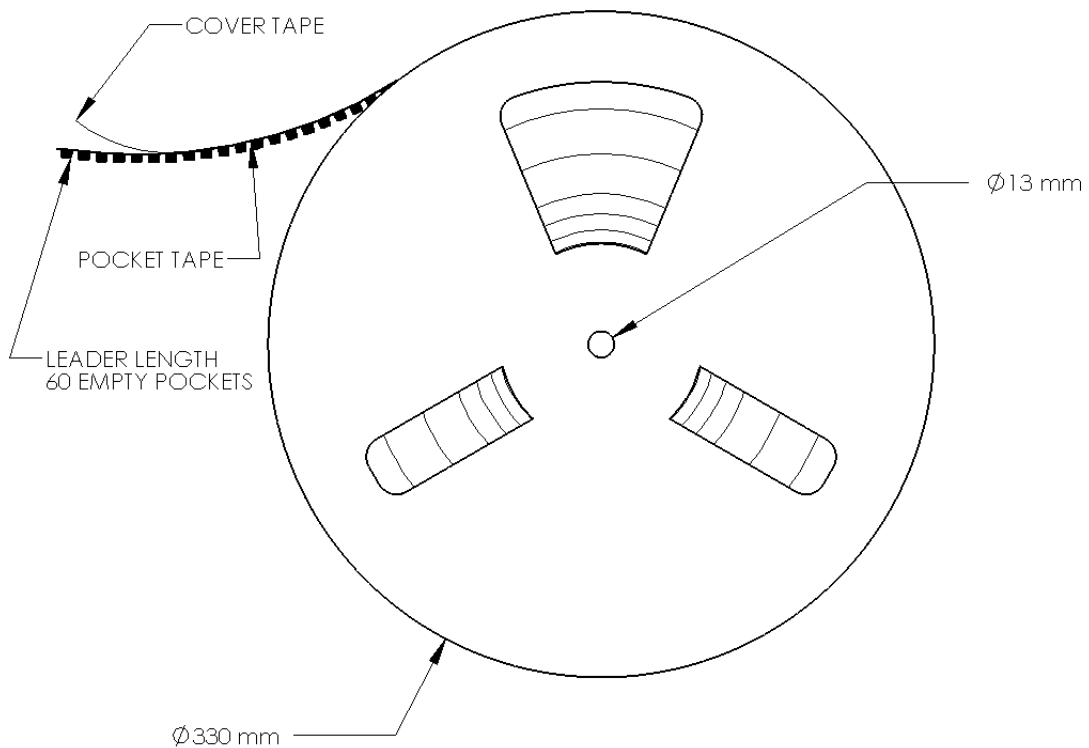

Figure 12: Emitter reel specifications (mm).

## Company Information

The LZ4-00R205 LED emitter is developed, manufactured, and marketed by LedEngin, Inc., located in Santa Clara, CA. LedEngin is a global market leader in advanced high-power LED emitters and light-source modules. LedEngin provides total solutions from 3W to 15W in single packages with ultra-small footprints in all colors from Cool White, Neutral White, Warm White, Red, Green, Blue, Amber, RGB, RGBA, Deep Red, Dental Blue and UV. LedEngin supports customers to generate solid-state lighting designs that conserve natural resources. LedEngin is focused on differentiated Ultra High-Brightness LED solutions for diverse global markets using its patent-pending package designs and manufacturing processes. LedEngin offers catalog as well as full custom solutions to enable flexible system designs for its customers. LedEngin is dedicated to long-term win-win partnering with its customers and suppliers.

LedEngin reserves the right to make changes to improve performance without notice.

Please contact [Sales@ledengin.com](mailto:Sales@ledengin.com) or (408) 492-0620 for more information.