

Features

- Adjustable constant output current
- Wide input voltage range
- Low drop voltage
- Open load detection
- Overtemperature protection
- Short circuit proof
- Reverse polarity proof
- Wide temperature range: $-40^{\circ}\text{C} < T_j < 150^{\circ}\text{C}$
- Very small SMD-Package
- Green Product (RoHS compliant)
- AEC Qualified

Potential applications

- Automotive LED exterior and interior lighting
- Blind spot detection

Product validation

Qualified for automotive applications.

Product validation according to AEC-Q100.

Description

The TLE4241GM is an integrated adjustable constant current source. It provides an output current adjustable via different means (SET, PWM, reference resistor) which is kept nearly independent from load and supply voltage changes. The IC is designed to supply LEDs under the severe conditions of automotive applications resulting in constant brightness and extended LED lifetime. It is provided in the very small PG-DSO-8 package. Protection circuits prevent damage to the device in case of overload, short circuit, reverse polarity and overtemperature. The connected LEDs are protected against reverse polarity as well as excess voltages up to 45 V. A status output allows handling of open load and short circuit at the main output.

A PWM input offers the possibility to adjust the LED brightness by pulse width modulation.

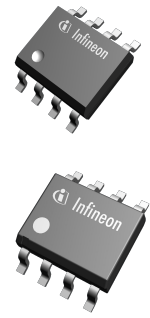

Type	Package
TLE4241GM	PG-DSO-8-16
TLE4241GM	PG-DSO-8-62

Table of contents

	Features	1
	Potential applications	1
	Product validation	1
	Description	1
	Table of contents	2
1	Circuit Description	3
2	Pin Configuration	4
3	Application Information	5
4	Electrical Characteristics	7
4.1	Absolute Maximum Ratings	7
4.2	Functional Range	8
4.3	Operating Range	8
4.4	Electrical Characteristics	9
5	Typical Performance Characteristics	11
6	Package Outlines	14
	Revision history	16
	Disclaimer	17

1 Circuit Description

With an implemented high/low current switch the output current level can be reduced e.g. for brake/tail light application.

The implemented features such as adjustable output current, the high/low current switch and the provided PWM input make the device well suited for a broad range of LED and other applications.

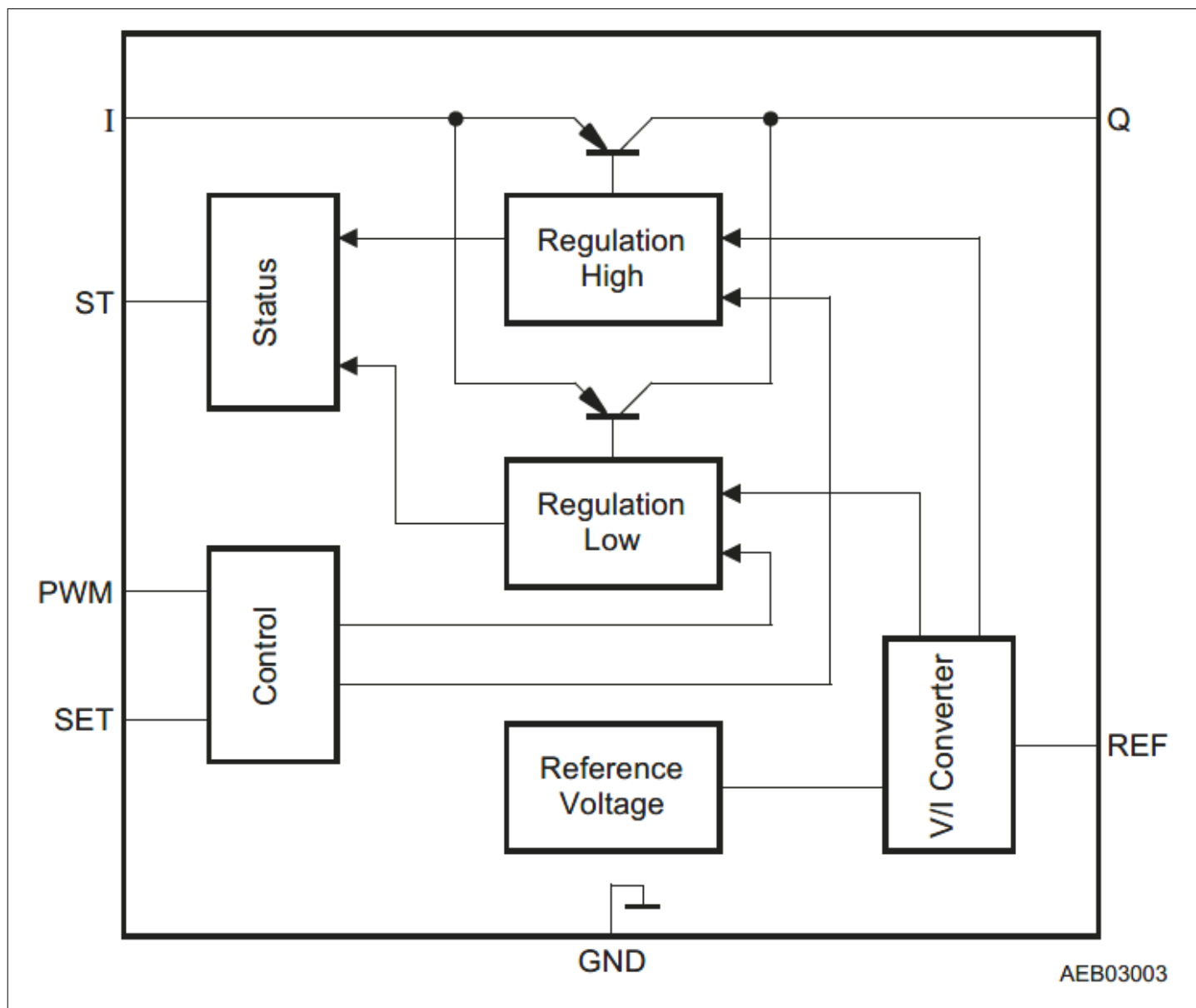

Figure 3 Block Diagram

2 Pin Configuration

An internal reference voltage of typ. 1.20 V supplies the REF pin which is connected to GND via an external resistor. In the SET = H mode the reference current flowing on the REF pin is mirrored with an amplification to form the desired output current. The typ. output current in the SET = H mode calculates:

$$I_{Q,typ}/mA = \frac{1.20}{R_{REF}/k\Omega} \times 487 + 0.1 \quad (1)$$

The output current is shown as a function of the reference resistance from Figure 7 to Figure 11 for the high as well as for the low current mode.

With the PWM input the LED brightness can be regulated via duty cycle. Also PWM = L sets the TLE4241GM in sleep mode resulting in a very low current consumption of <<1 μA typ. Due to the high impedance of the PWM input (see timing diagram I_{PWM} versus V_{PWM} from Figure 12 to Figure 15) the PWM pin can thus also be used as an Enable input.

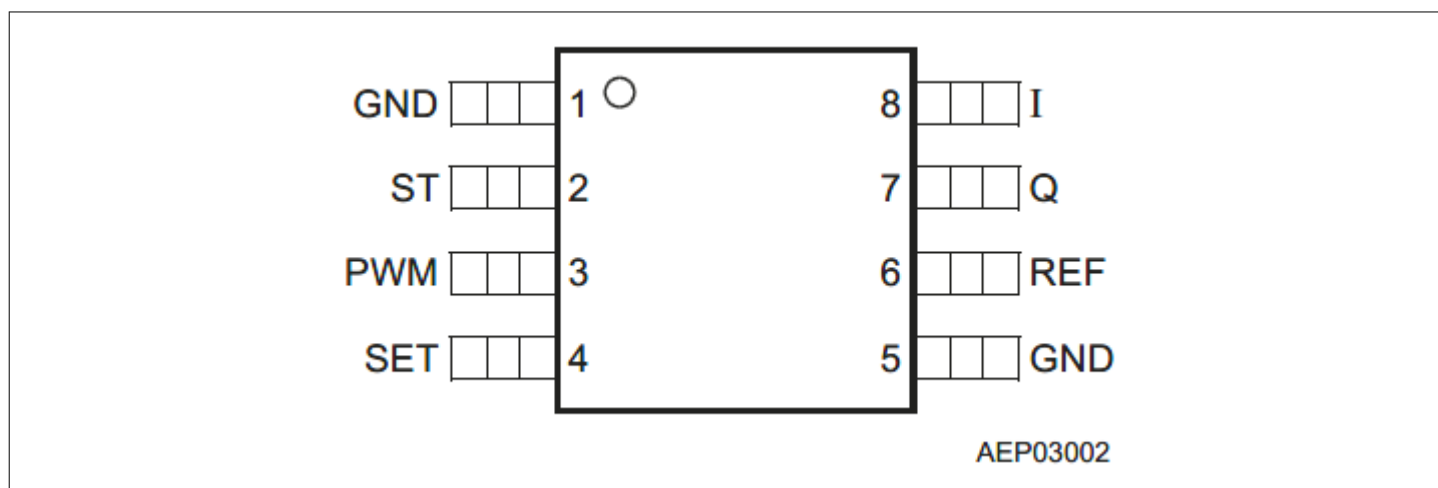

Figure 4 Pin Configuration (top view)

Table 1 Pin Definitions and Functions

Pin No.	Symbol	Function
1	GND	Ground ; internally connected to pin 5
2	ST	Status Output ; open collector output, connect to external pull-up resistor (10 kΩ or higher)
3	PWM	Pulse Width Modulation Input ; if not needed connect to V_I
4	SET	High/Low Current Input ; choice of current level
5	GND	Ground ; internally connected to pin 1
6	REF	Reference Input ; connect to GND via an external resistor to adjust the output current
7	Q	Output
8	I	Input ; block to GND directly at the IC with a 100 nF ceramic capacitor

3 Application Information

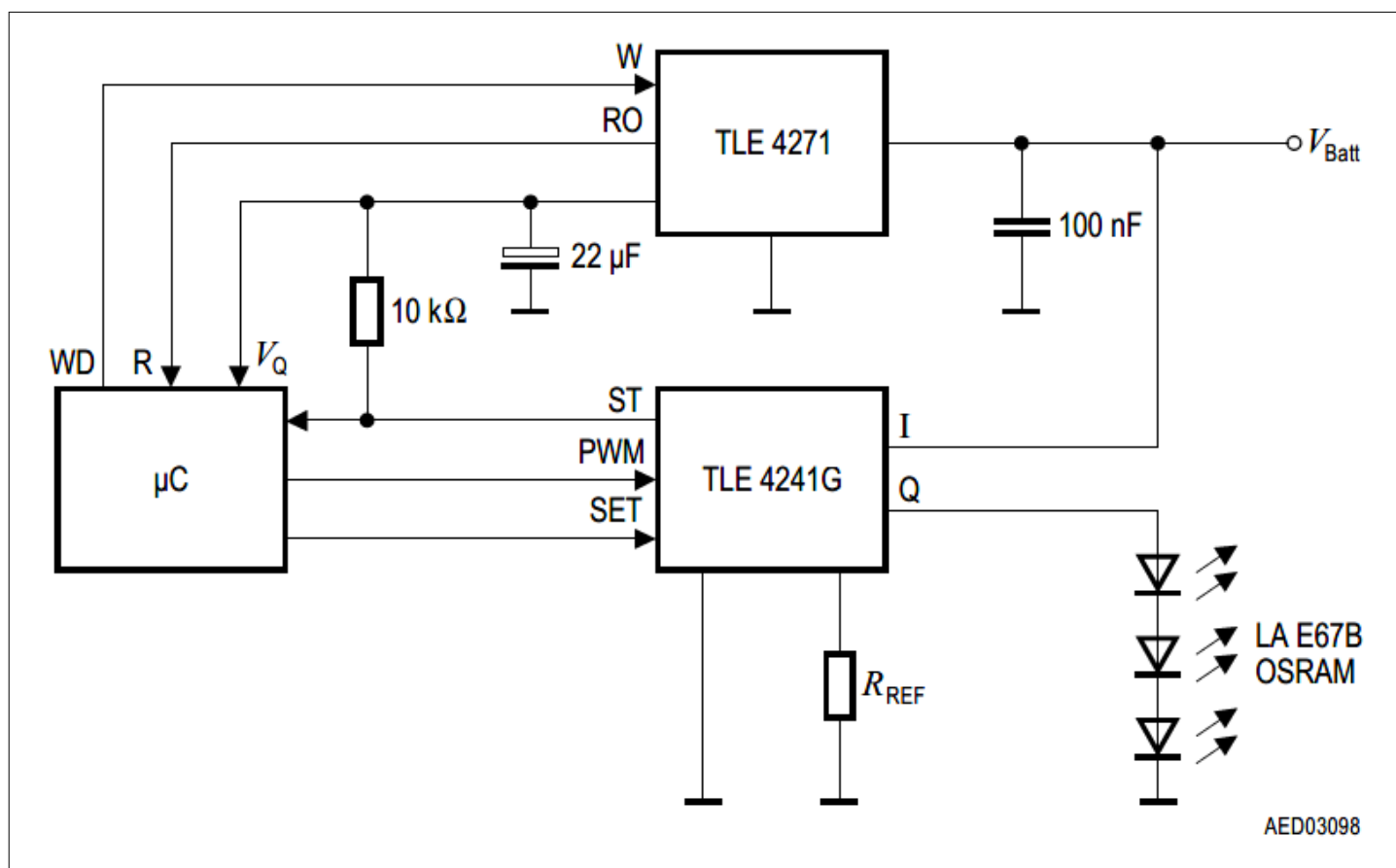

Figure 5 Application Circuit

Figure 5 shows a typical application with the TLE4241GM LITIX™ Linear. The 3 LEDs are driven with an adequate supply current adjusted by the resistor R_{REF} . Thus brightness variations due to forward voltage spread of the LEDs are prevented. The luminosity spread arising from the LED production process can be compensated via software by an appropriate duty cycle applied to the PWM pin. Hence selection of the LEDs to forward voltage as well as to luminosity classes can be spared. The slightly negative temperature coefficient of the TLE4241GM output current protects the LEDs against over-temperature stress if the IC is placed nearby the LEDs.

The voltage drop ($V_I - V_Q$) across the TLE4241GM is monitored in order to detect an open load condition indicated at the status output pin ST. In case of open load, the voltage drop will decrease below the lower status switching threshold $V_{dr,L}$. Hence, the status output ST will be driven low. In normal operation, the voltage drop is above the upper status threshold $V_{dr,H}$, thus the open collector output ST is in high-ohmic state (see also section Status Output at the Electrical Characteristics).

The function of ST, SET and PWM as well as their timings are shown in Figure 6.

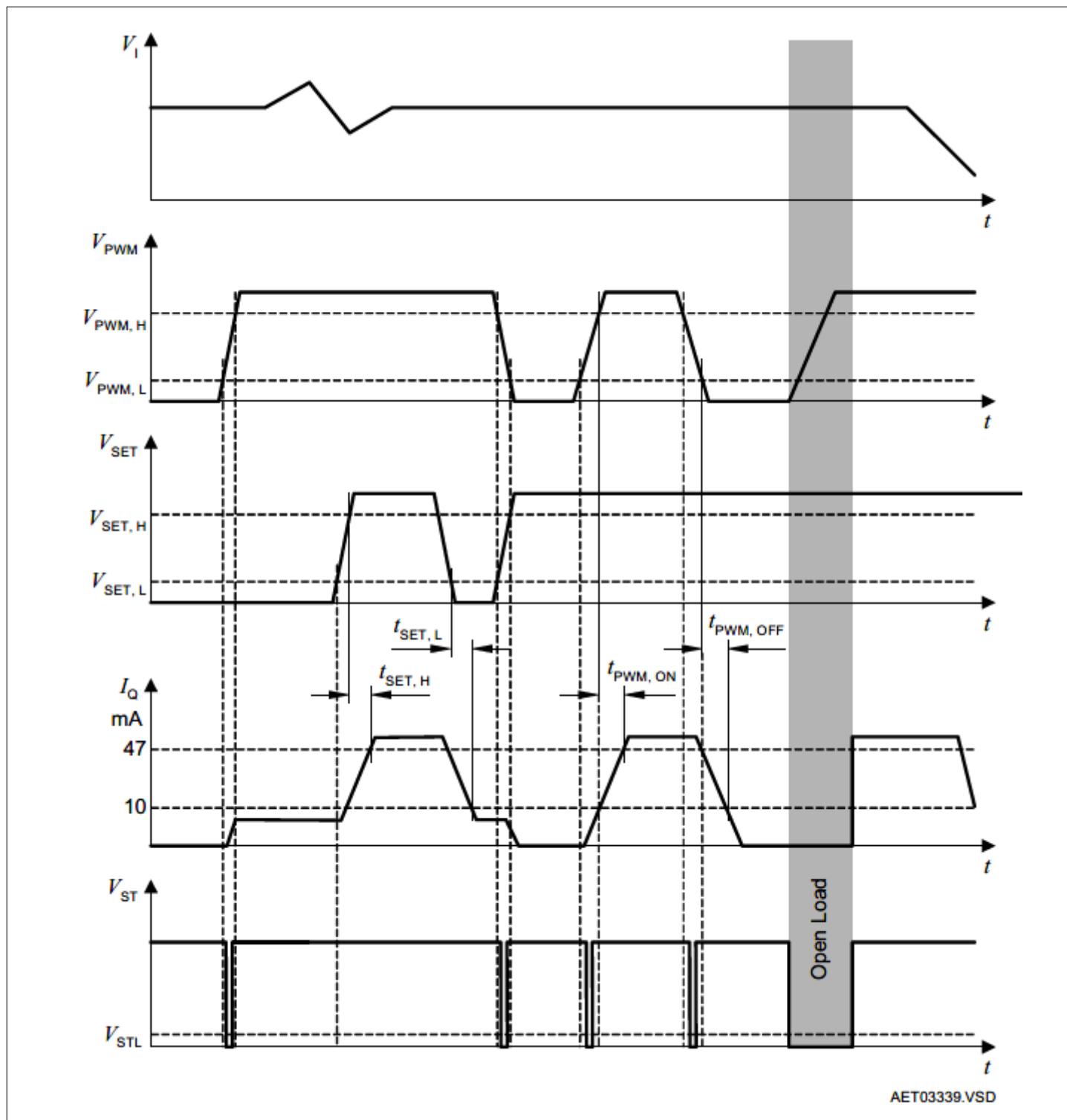

Figure 6 Function and Timing Diagram

4 Electrical Characteristics

4.1 Absolute Maximum Ratings

Table 2 Absolute Maximum Ratings

$-40^{\circ}\text{C} < T_j < 150^{\circ}\text{C}$

Parameter	Symbol	Limit Values		Unit	Note or test condition
		Min.	Max.		
Input					
Voltage	V_I	-42	45	V	–
Current	I_I	–	–	mA	internally limited
Output					
Voltage	V_Q	-1	40	V	–
Current	I_Q	–	–	mA	internally limited
Status Output					
Voltage	V_{ST}	-0.3	40	V	–
Current	I_{ST}	– 5	5	mA	internally limited
Reference Input					
Voltage	V_{REF}	-0.3	7	V	–
Current	I_{REF}	-2	2	mA	–
Pulse Width Modulation Input					
Voltage	V_{PWM}	-40	40	V	–
Current	–	-1	1	mA	–
High/Low Current Input					
Voltage	V_{SET}	-40	40	V	–
Current	I_{SET}	-1	1	mA	–
Temperatures					
Junction temperature	T_j	-40	150	$^{\circ}\text{C}$	–
Storage temperature	T_{stg}	-50	150	$^{\circ}\text{C}$	–
Thermal Resistances					
Junction ambient 1s0p board	R_{thja1}	–	–	K/W	1) 2)
			173		$T_a = 85^{\circ}\text{C}$
			163		$T_a = 125^{\circ}\text{C}$
Junction to ambient 2s2p board	R_{thja2}	–	–	K/W	1) 3)
			114		$T_a = 85^{\circ}\text{C}$
			112		$T_a = 125^{\circ}\text{C}$

1) Not subject to production test, specified by design. Based on simulation results

2) The R_{thja1} values are according to JEDEC JESD51-3 at natural convection on 1s0p FR4 board. The product (chip + package) was simulated on a 76.2 x 114.3 x 1.5 mm³ board with 70 μm Cu. Total power dissipation 0.5 W in active area

4 Electrical Characteristics

3) The R_{thja2} values are according to JEDEC JESD51-7 at natural convection on 2s2p FR4 board. The product (chip + package) was simulated on a 76.2 x 114.3 x 1.5 mm³ board with 2 inner copper layers (outside 2 x 70 μm Cu, inner 2 x 35 μm Cu). Total power dissipation 0.5 W in active area

Note: *Maximum ratings are absolute ratings; exceeding any one of these values may cause irreversible damage to the integrated circuit.*

4.2 Functional Range

Table 3 Functional Range

Parameter	Symbol	Limit Values		Unit	Note or test condition
		Min.	Max.		
Input voltage	V_I	9	16	V	–
Output voltage	V_Q	0	14	V	–
SET voltage	V_{SET}	0	16	V	–
PWM voltage	V_{PWM}	0	16	V	–
Output current	I_Q	0	85	mA	–
Junction temperature	T_j	-40	150	°C	–

4.3 Operating Range

Table 4 Operating Range

Parameter	Symbol	Limit Values		Unit	Note or test condition
		Min.	Max.		
Input voltage	V_I	4	40	V	–
Status output voltage	V_{ST}	–	16	V	–
SET voltage	V_{SET}	0	40	V	–
PWM voltage	V_{PWM}	0	40	V	–
Junction temperature	T_j	-40	150	°C	–
Reference Resistor	R_{REF}	7	100	kΩ	SET = H
		4.7	18	kΩ	SET = L

4.4 Electrical Characteristics

Table 5 Electrical Characteristics

$9\text{ V} \leq V_1 \leq 16\text{ V}$; $R_{\text{REF}} = 10\text{ k}\Omega$; $V_{\text{PWM}} \geq V_{\text{PWM,H}}$; $-40^\circ\text{C} < T_j < 150^\circ\text{C}$; all voltages with respect to ground; positive current defined flowing into pin; unless otherwise specified

Parameter	Symbol	Limit Values			Unit	Note or test condition
		Min.	Typ.	Max.		
Current consumption off mode	I_{qOFF}	–	0.1	4	μA	PWM = L, $T_j < 85^\circ\text{C}$; $V_1 \leq 13.5\text{ V}$
Current consumption	I_{qL}	–	4	7	mA	SET = L; $V_Q = 6\text{ V}$
Current consumption	I_{qH}	–	5	7	mA	SET = H; $V_Q = 6\text{ V}$
Current consumption open load	$I_{\text{qL,O}}$	–	–	8	mA	SET = L; V_Q open
Current consumption open load	$I_{\text{qH,O}}$	–	–	8	mA	SET = H; V_Q open

Output

Output current	I_Q	7	8.4	9.5	mA	SET = L, $V_Q = 6\text{ V}$
		–	8.6	–	mA	SET = L, $V_Q = 4\text{ V}$
Output current	I_Q	50	58.5	65	mA	SET = H, $V_Q = 6\text{ V}$
		–	60.0	–	mA	SET = H, $V_Q = 4\text{ V}$
Current Ratio	$I_{\text{qH}}/I_{\text{qL}}$	6	7	8	–	–
Output current limit	I_{Qmax}	–	83	–	mA	SET = L; $R_{\text{REF}} = 0\ \Omega$
Output current limit	I_{Qmax}	–	83	–	mA	SET = H; $R_{\text{REF}} = 0\ \Omega$
Drop voltage	V_{dr}	–	0.2	0.5	V	SET = L; $I_Q = 80\%$ of $I_{\text{Q,nom,L}}$
Drop voltage	V_{dr}	–	0.3	0.5	V	SET = H; $I_Q = 80\%$ of $I_{\text{Q,nom,H}}$

PWM Input

PWM high level	$V_{\text{PWM,H}}$	2.0	–	–	V	–
PWM low level	$V_{\text{PWM,L}}$	–	–	0.5	V	–
PWM input current high level	$I_{\text{PWM,H}}$	–	220	500	μA	$V_{\text{PWM}} = 5.0\text{ V}$
PWM input current low level	$I_{\text{PWM,L}}$	-10	–	10	μA	$V_{\text{PWM}} = 0.0\text{ V}$
Turn on delay time	$t_{\text{PWM,ON}}$	0	5	30	μs	20%/80% I_Q , see Figure 6
Turn off delay time	$t_{\text{PWM,OFF}}$	0	10	30	μs	20%/80% I_Q , see Figure 6

SET Input

SET high level	$V_{\text{SET,H}}$	2.0	–	–	V	–
SET low level	$V_{\text{SET,L}}$	–	–	0.5	V	–
SET input current high level	$I_{\text{SET,H}}$	–	220	500	μA	$V_{\text{SET}} = 5.0\text{ V}$
SET input current low level	$I_{\text{SET,L}}$	-10	–	10	μA	$V_{\text{SET}} = 0.0\text{ V}$
Delay time L → H	$t_{\text{SET,H}}$	–	–	30	μs	20%/80% I_Q , see Figure 6
Delay time H → L	$t_{\text{SET,L}}$	–	–	30	μs	20%/80% I_Q , see Figure 6

(table continues...)

Table 5 (continued) Electrical Characteristics

$9\text{ V} \leq V_I \leq 16\text{ V}$; $R_{REF} = 10\text{ k}\Omega$; $V_{PWM} \geq V_{PWM,H}$; $-40^\circ\text{C} < T_j < 150^\circ\text{C}$; all voltages with respect to ground; positive current defined flowing into pin; unless otherwise specified

Parameter	Symbol	Limit Values			Unit	Note or test condition
		Min.	Typ.	Max.		
Status Output						
Lower status switching threshold	$V_{dr,L}$	0.15	–	–	V	$(V_I - V_Q)$ decreasing SET = L
		0.15	–	–	V	$(V_I - V_Q)$ decreasing SET = H
Upper status switching threshold	$V_{dr,H}$	–	–	0.7	V	$(V_I - V_Q)$ increasing SET = L
		–	–	0.7	V	$(V_I - V_Q)$ increasing SET = H
Status low voltage	V_{STL}	–	–	0.4	V	$(V_I - V_Q) < V_{dr,L}$ $I_{ST} = 1.0\text{ mA}$
Leakage current	I_{STLK}	–	–	10	μA	$(V_I - V_Q) > V_{dr,H}$ $V_{ST} = 5.0\text{ V}$

5 Typical Performance Characteristics

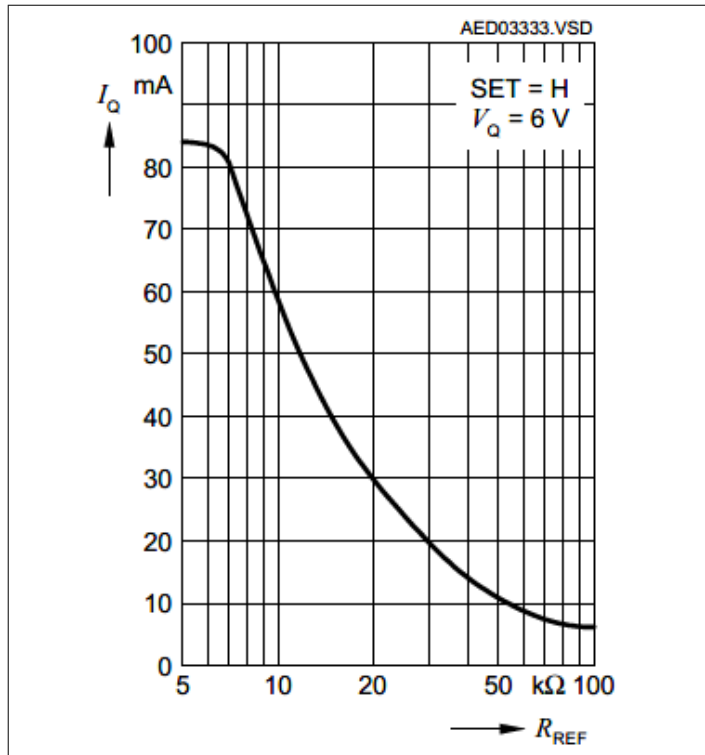

Figure 7 Output Current versus External Resistor, SET = H

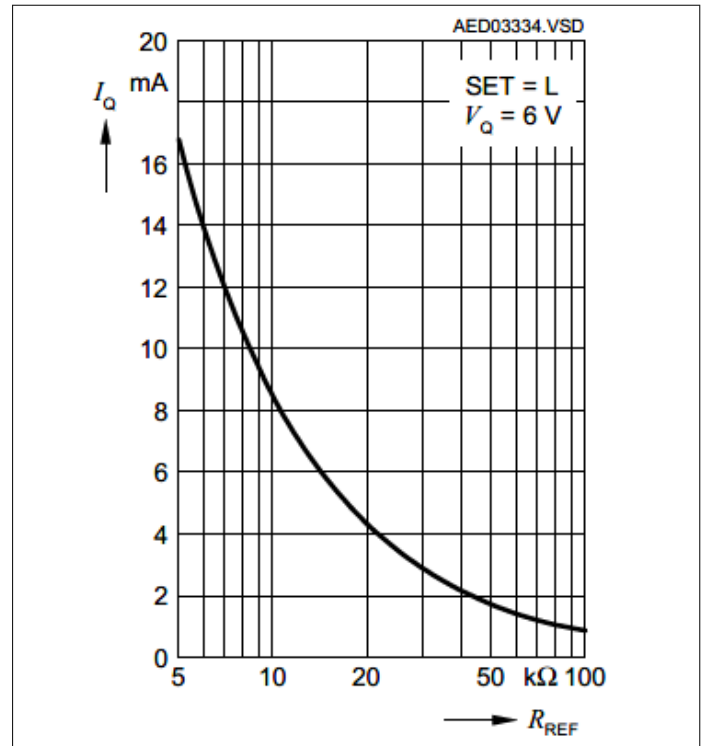

Figure 8 Output Current versus External Resistor, SET = L

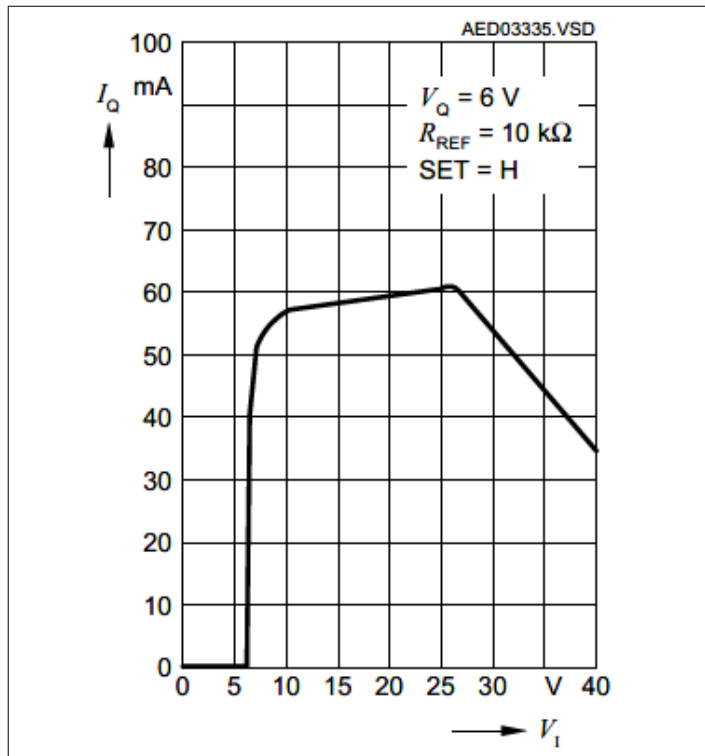

Figure 9 Output Current versus Supply Voltage, SET = H

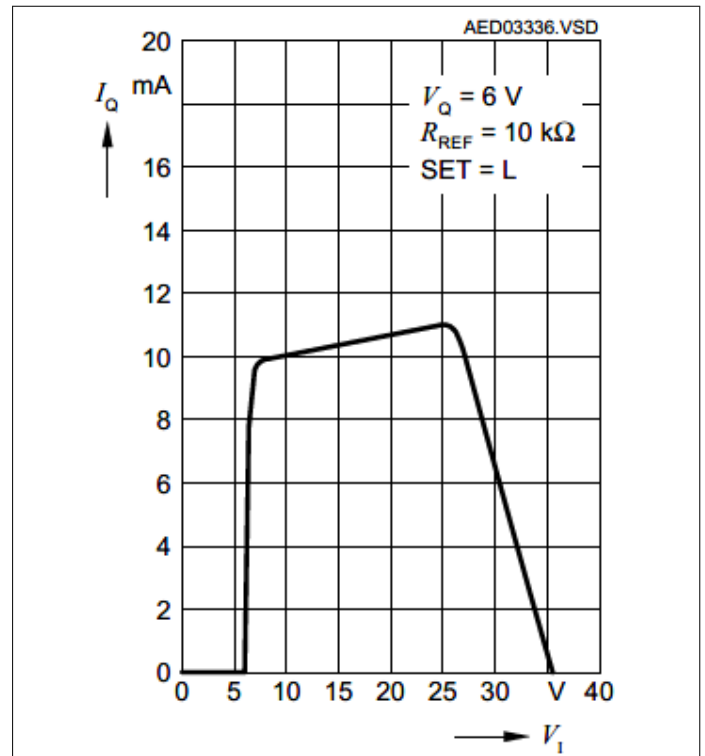

Figure 10 Output Current versus Supply Voltage, SET = L

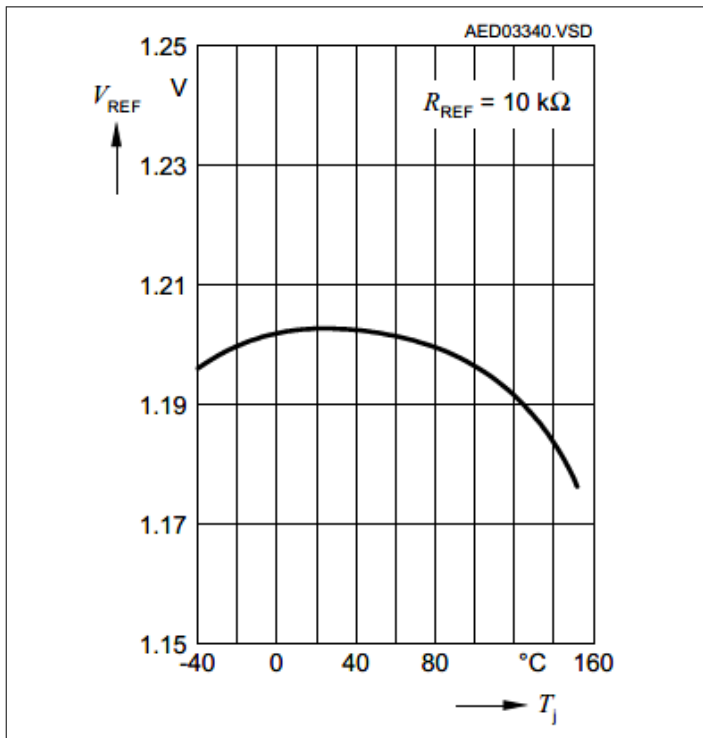

Figure 11 Reference Voltage versus Junction Temperature

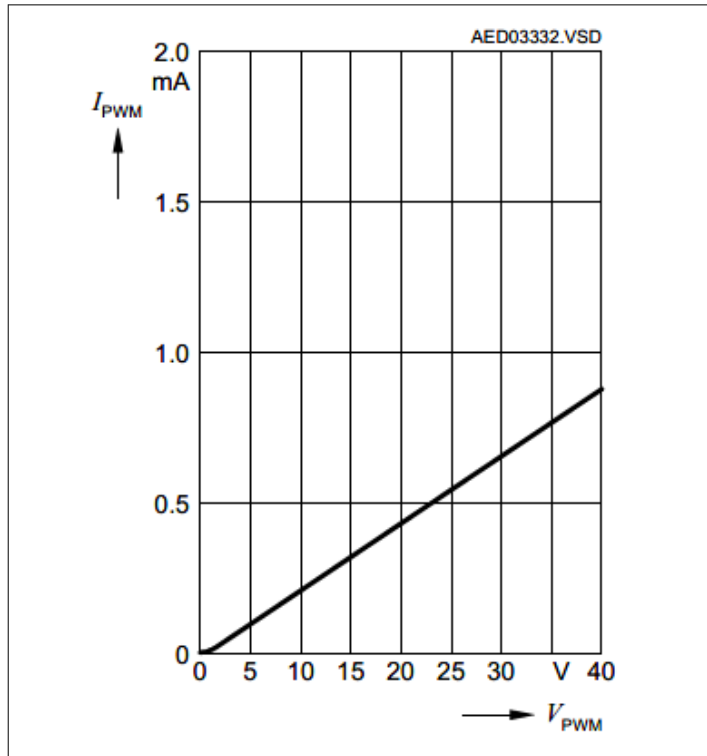

Figure 12 PWM Pin Input Current versus PWM Voltage

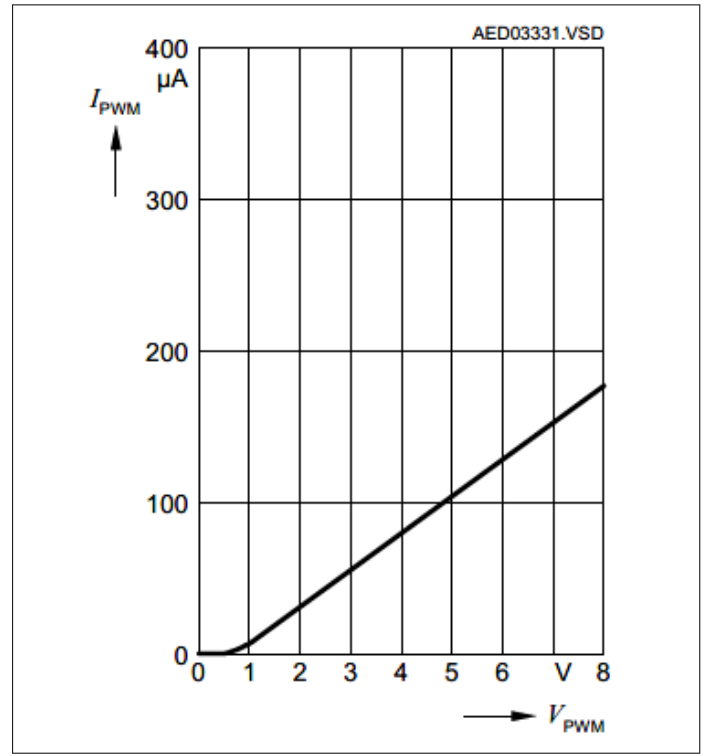

Figure 13 PWM Pin Input Current versus PWM Voltage

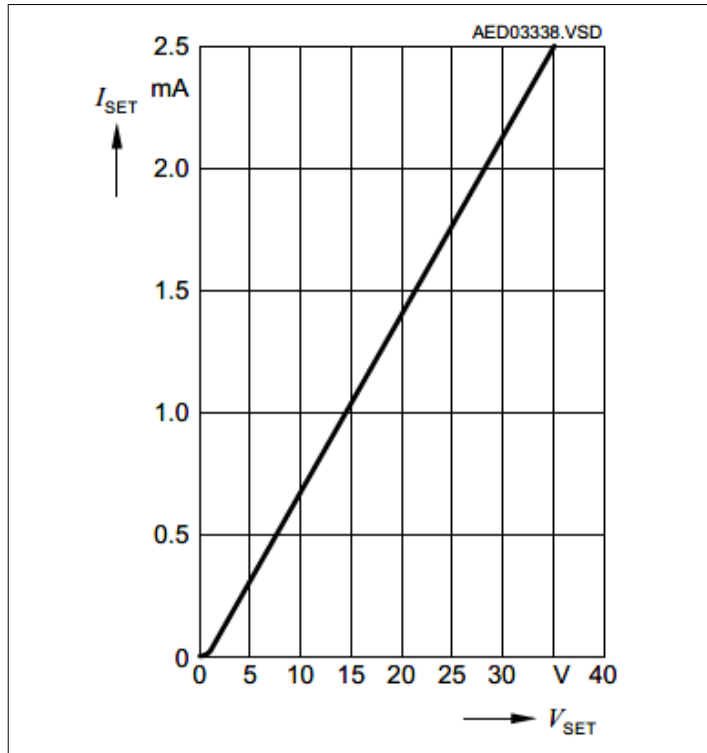

Figure 14 SET Pin Input Current versus SET Voltage

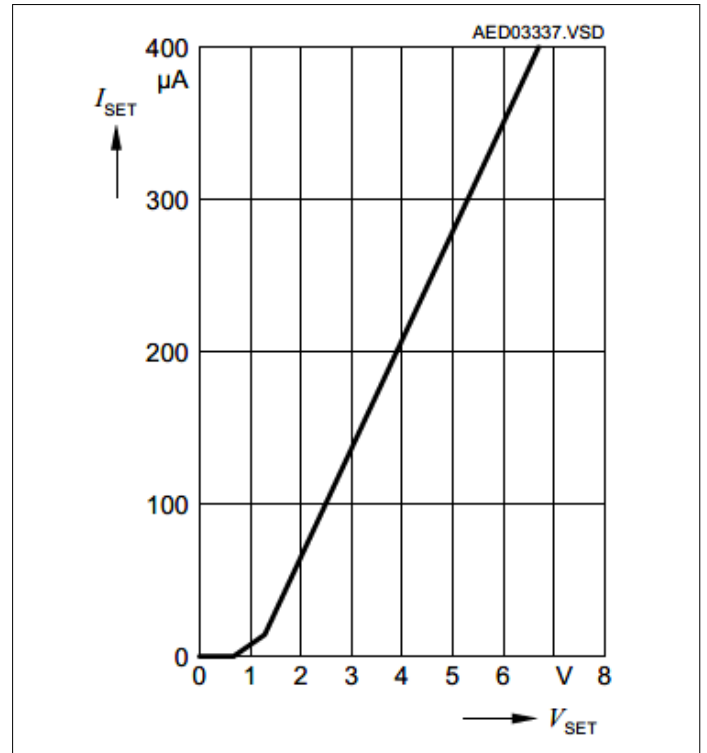

Figure 15 SET Pin Input Current versus SET Voltage

6 Package Outlines

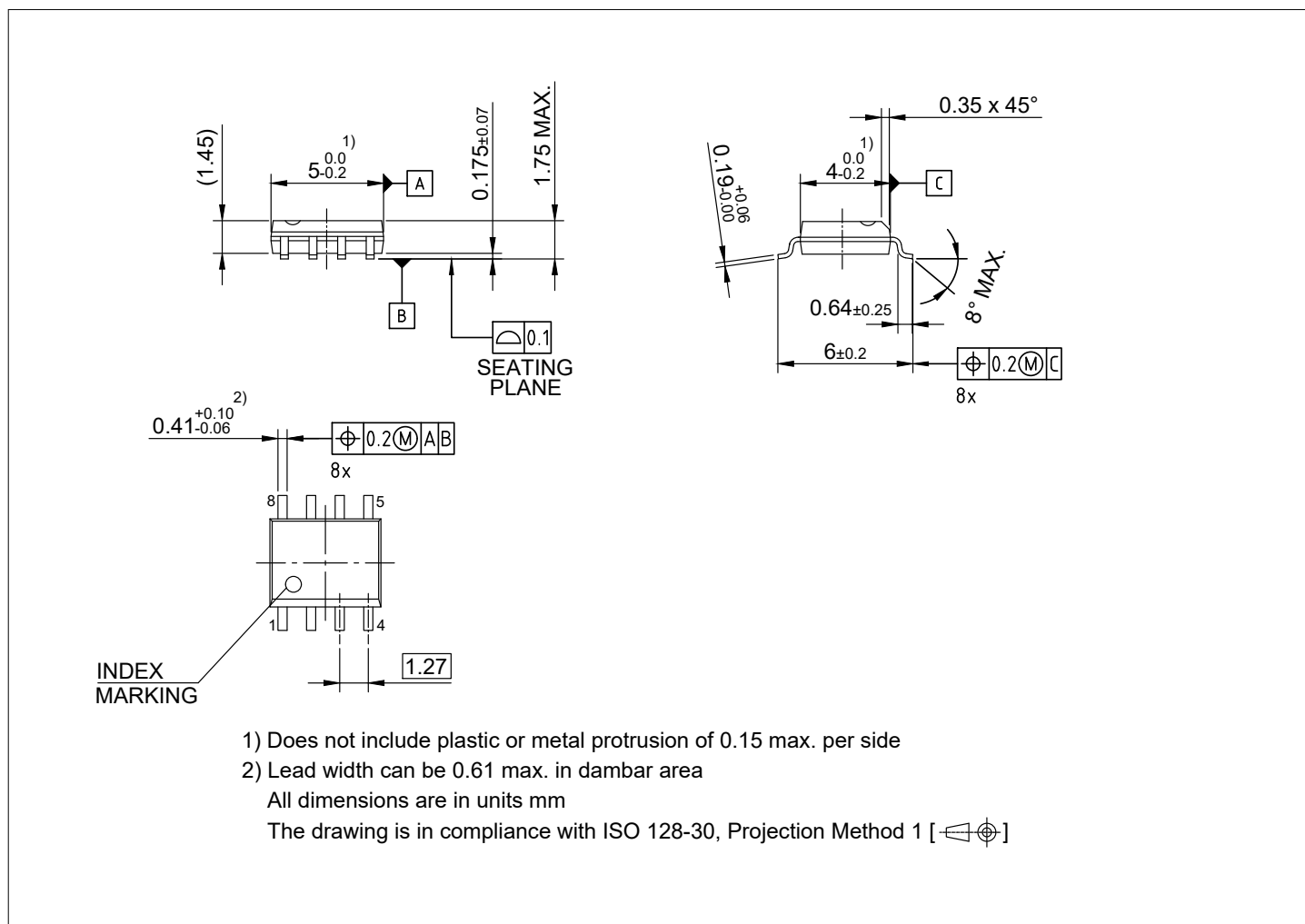

Figure 16 PG-DSO-8-16

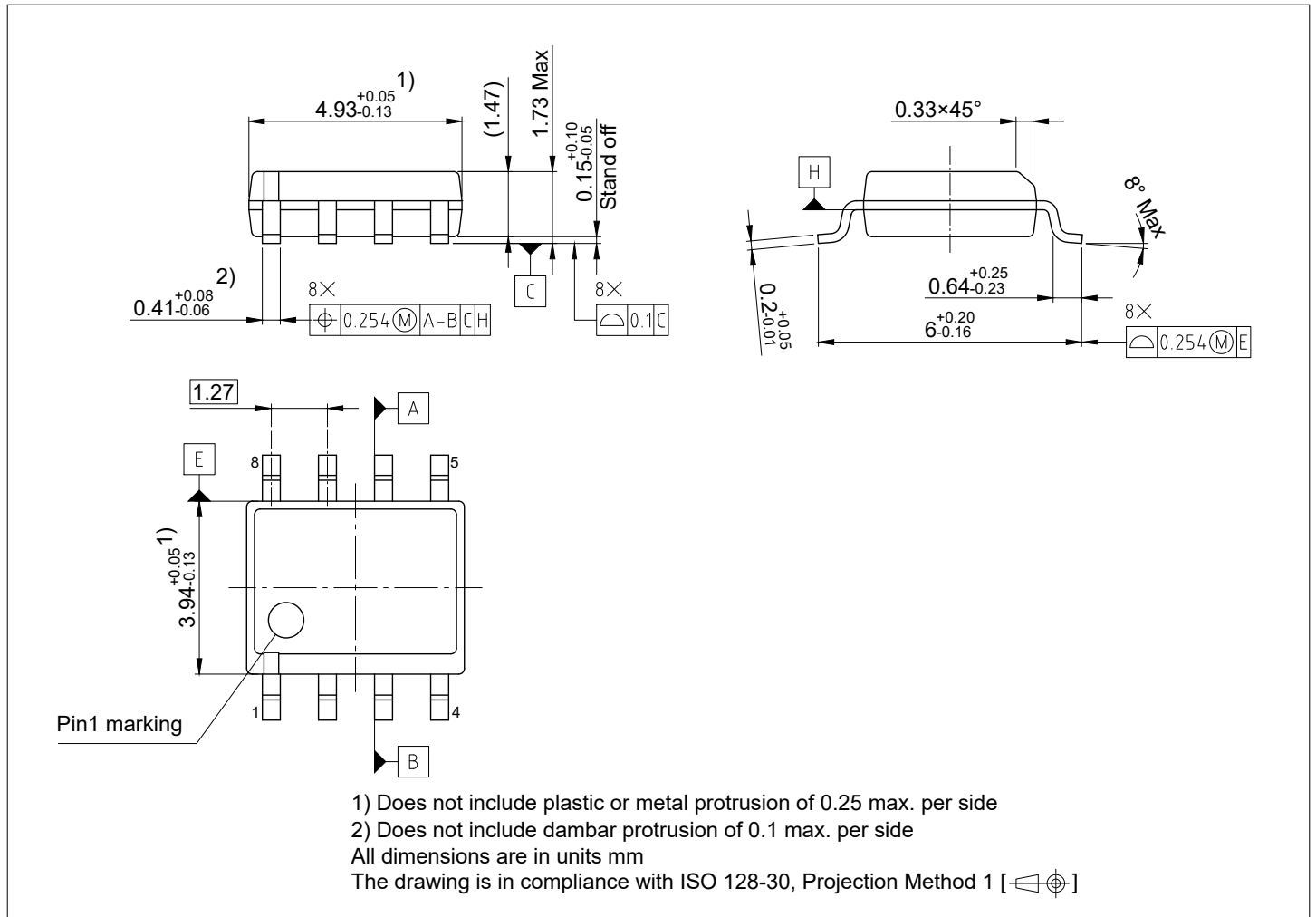

Figure 17 PG-DSO-8-62

Green Product (RoHS compliant)

To meet the world-wide customer requirements for environmentally friendly products and to be compliant with government regulations the device is available as a green product. Green products are RoHS-Compliant (i.e Pb-free finish on leads and suitable for Pb-free soldering according to IPC/JEDEC J-STD-020).

Note: You can find all of our packages, sorts of packing and others in our Infineon Internet Page “Products”:
<http://www.infineon.com/products>

SMD = Surface Mounted Device

(Dimensions in mm)

Revision history

Document version	Date of release	Description of changes
1.70	2025-11-05	<ul style="list-style-type: none"> Package Outlines updated: PG-DSO-8-16 and PG-DSO-8-62 added Ordering information updated: PG-DSO-8-16 and PG-DSO-8-62 added
1.60	2024-11-15	<ul style="list-style-type: none"> Updated V_I of Table Operating Range
1.5	2023-09-27	<ul style="list-style-type: none"> Editorial updates - minor typos Updated PG-DSO-8-9 → PG-DSO-8 Updated package figure on Page 1 Added Potential Applications on Page 1 Updated TLE4241 → TLE4241GM Updated Thermal resistance → Page 6 Updated V_I of Table Operating Range Added Table Functional Range Electrical Characteristics updated Page 8
1.4	2015-07-09	<ul style="list-style-type: none"> Electrical Characteristics updated Page 9
1.3	2007-03-19	<ul style="list-style-type: none"> Initial version of RoHS-compliant derivate of TLE4241GM Page 1: AEC certified statement added Page 1 and Page 14: RoHS compliance statement and Green product feature added Page 1 and Page 14: Package changed to RoHS compliant version Legal Disclaimer updated
1.2	2004-04-13	<ul style="list-style-type: none"> Page 5 and Page 9: Improved indication and explanation of the open load detection function

Trademarks

All referenced product or service names and trademarks are the property of their respective owners.

Edition 2025-11-05

Published by

Infineon Technologies AG

81726 Munich, Germany

© 2025 Infineon Technologies AG

All Rights Reserved.

Do you have a question about any aspect of this document?

Email: erratum@infineon.com

Document reference

IFX-obo1717485324221

Important notice

The information given in this document shall in no event be regarded as a guarantee of conditions or characteristics ("Beschaffheitsgarantie").

With respect to any examples, hints or any typical values stated herein and/or any information regarding the application of the product, Infineon Technologies hereby disclaims any and all warranties and liabilities of any kind, including without limitation warranties of non-infringement of intellectual property rights of any third party.

In addition, any information given in this document is subject to customer's compliance with its obligations stated in this document and any applicable legal requirements, norms and standards concerning customer's products and any use of the product of Infineon Technologies in customer's applications.

The data contained in this document is exclusively intended for technically trained staff. It is the responsibility of customer's technical departments to evaluate the suitability of the product for the intended application and the completeness of the product information given in this document with respect to such application.

Warnings

Due to technical requirements products may contain dangerous substances. For information on the types in question please contact your nearest Infineon Technologies office.

Except as otherwise explicitly approved by Infineon Technologies in a written document signed by authorized representatives of Infineon Technologies, Infineon Technologies' products may not be used in any applications where a failure of the product or any consequences of the use thereof can reasonably be expected to result in personal injury.