

## Chip Inductors for RF Applications / Medical Applications (Wire wound-open)

FASTRON's wire wound chip inductors are designed for radio frequency (RF) applications that require optimal Q on high frequency circuits. Its gold flash pad metallization provides better solderability for a higher yield in production. Additionally, their encapsulation not only protects the winding but also allows for surface mount assembly. It comes in compact sizes (from 0302 to 1812) and is available in reel packaging. Unlisted inductance values are usually available upon request. Ferrite core versions are also available for selected case sizes for applications which require higher inductances in a smaller case size.

**Applications** Used in LC resonant circuits such as oscillator and signal generators, impedance matching, RF filters etc.  
 Mobile Telecommunication: GSM, CDMA, TCDMA, cordless phones, 2 way radio  
 Automotive Subsystems: TPMS, Keyless Entry, Anti-Theft, GPS  
 Wireless Communication: W-LAN, WIFI, WIMAX, RFID, Bluetooth  
 Non-magnetic versions for medical imaging applications: ASM series

### Technical Data

L – Value (Rated Inductance)	≥ 1 MHz measured with HP 4286A RF LCR meter or equivalent at frequency $f_L$ , 25°C ambient < 1 MHz measured with HP 4285A or equivalent at frequency $f_L$ , 25°C ambient
Q – Factor (min)	≥ 1 MHz measured with E4991B Impedance Analyzer or equivalent at frequency $f_Q$ , 25°C ambient < 1 MHz measured with HP 4285A or equivalent at frequency $f_Q$ , 25°C ambient
SRF (min)	Measured with HP8753ES Network Analyzer or equivalent at 25°C ambient
DCR (max)	Measured at 25°C ambient
Rated DC Current: Irms	Max permissible current that causes a 15°C component temperature rise from 25°C ambient for AS (except 0302AS), AQ, ASM, F & AF Max permissible current that causes a 30°C component temperature rise from 25°C ambient for 0302AS Max permissible current that causes a 40°C component temperature rise from 25°C ambient for AQC, FLP & LDM
Saturation Current: Isat	Max permissible DC bias at 25°C ambient that causes inductivity drop 30% (typ.) related to the unloaded inductivity for FLP & LDM.
Operating Temperature	-40°C to +100°C (Including component self-heating): F & AF -40°C to +125°C (Including component self-heating): FLP & LDM -40°C to +140°C (Including component self-heating): AS (except 0302AS), AQ, ASM & AQC -40°C to +155°C (Including component self-heating): 0302AS
Surface Finishing	Epoxy molded flat top for perfect pick and place assembly
Pad Metallization	Gold flash as top layer for AS, AQ, F, AF & FLP Silver-Palladium-Platinum for ASM & AQC Tin as top layer for LDM
Wire Termination	Spot welding
Recommended Soldering Method	<u>Reflow</u>
Moisture Sensitivity Levels (MSL)	MSL Level 1, indicating unlimited floor life at ≤ 30°C / 85% relative humidity
Solderability	Using lead-free solder (Sn 99.9) at 260°C ± 5°C for 5 ± 0.5 seconds, min 90% solder coverage of metallization Standard: IEC 68-2-20 (Ta)
Resistance to Soldering Heat	Resistant to 260°C ± 5°C for 10 ± 1 seconds Standard: IEC 68-2-20 (Tb)
Resistance to Solvent	Resistant to isopropyl alcohol for 5 ± 0.5 minutes at 23°C ± 5°C Standard: IEC 68-2-45
Climatic Test	Defined by the following standards: IEC 68-2-1 for Cold test: -55°C for 96 hours IEC 68-2-2 for Dry heat test: +85°C for ferrite core and 125°C for ceramic core for 96 hours IEC 60068-2-78 for Humidity test: 40°C at RH 95% for 4 days
Thermal Shock Test	Temperature cycle (ceramic): -40°C to +125°C to -40°C Temperature cycle (ferrite): -40°C to +85°C to -40°C Max/Min temperature duration: 15 minutes Temperature transition duration: 5 minutes Cycles: 25 Standard: MIL-STD-202G
Adhesion of Soldered Component (Shear Test)	Components withstand a pushing force of 10N for 10 ± 1 seconds Standard: IEC 60068-2-21, method Ue <sub>3</sub>
Mechanical Shock	Mil-Std 202 Method 213, Condition C 3 axis, 6 times, total 18 shocks 100 G, 6 ms, half-sine
Vibration	Mil-Std 202 Method 204 20 mins at 5G 10 Hz to 2000 Hz 12 cycles each of 3 orientations

Technical Data

## Chip Inductors for RF Applications / Medical Applications (Wire wound-open)

Ordering Code Example : 0402AS-1N0X-YY → **0402AS-1N0K-01**

**0402 AS - 1N0 X - YY**  
(Case Size) (Core Type) (Inductance Value) (Tolerance) (Packaging Code)

Case Sizes - 0302, 0402, 0603, 0805, 1008, 1206, 1210, 1812

Core Type - AS, AQ, AQC, ASM (Ceramic), F (Ferrite), AF (Ceramic & Ferrite), FLP (Ferrite Low Profile)

Tolerances - F ( $\pm 1\%$ ), G ( $\pm 2\%$ ), A ( $\pm 3\%$ ), J ( $\pm 5\%$ ), K ( $\pm 10\%$ ), L ( $\pm 15\%$ ), M ( $\pm 20\%$ )

Packaging Code - 01, 04, 08 (Taped / Reel)

### Packaging Specification Schematic

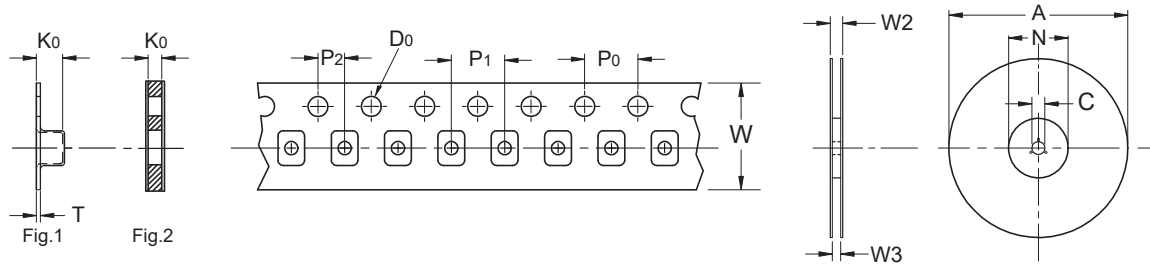

Type	Packaging Code	A	D0	N	C	W2	W3	W	P1	P0	P2	K0	T	Fig
0302	01,08	180	1.55	60	13	11.9	9.5	8	2	4	2	0.50	-	2
0402	01,08	180	1.55	60	13	11.9	9.5	8	2	4	2	0.60	-	2
0603	01,08	180	1.55	60	13	11.4	9.0	8	4	4	2	0.98	-	2
0603	04	330	1.55	100	13	14.4	8.4	8	4	4	2	0.98	-	2
0805	01,08	180	1.55	60	13	11.4	9.0	8	4	4	2	1.63	0.25	1
0805	04	330	1.55	100	13	14.4	8.4	8	4	4	2	1.63	0.25	1
1008	01,08	180	1.50	60	13	11.4	9.5	8	4	4	2	2.23	0.30	1
1008	04	330	1.55	100	13	14.4	8.4	8	4	4	2	1.63	0.25	1
1206	01,08	180	1.50	60	13	18.4	13.7	12	4	4	2	1.80	0.30	1
1206	04	330	1.50	100	13	18.4	12.4	12	4	4	2	1.80	0.30	1
1210	01	180	1.55	60	13	18.4	13.7	12	8	4	2	2.55	0.30	1
1210	04	330	1.55	100	13	18.4	12.4	12	8	4	2	2.55	0.30	1
1812	01	180	1.50	60	13	18.4	13.7	12	8	4	2	3.70	0.35	1
1812	04	330	1.50	100	13	18.4	12.4	12	8	4	2	3.70	0.35	1

# 1206 AS

Engineer's Kit: EK-1206AS-X

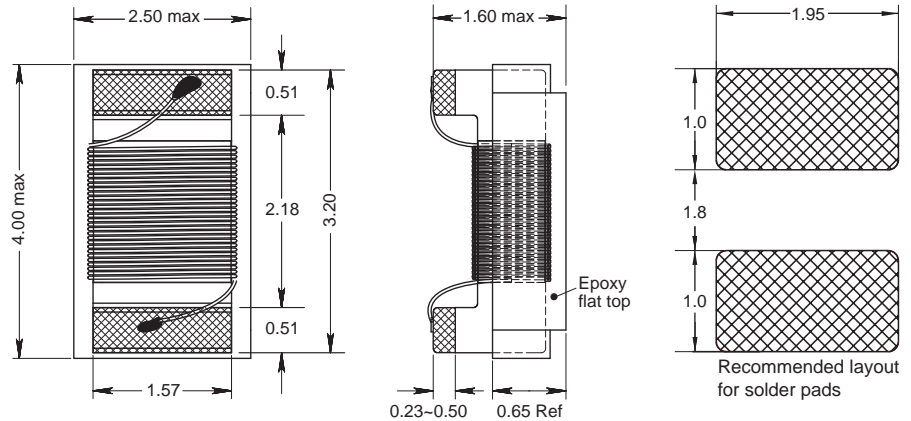
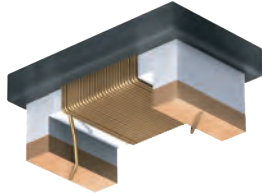

Chip Inductors for RF Applications

(Wire wound - open)

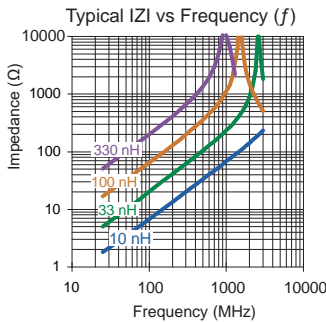
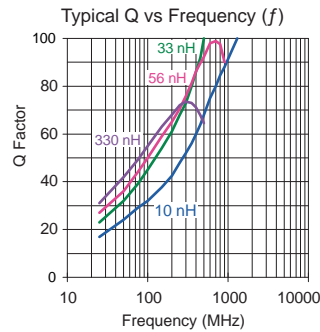
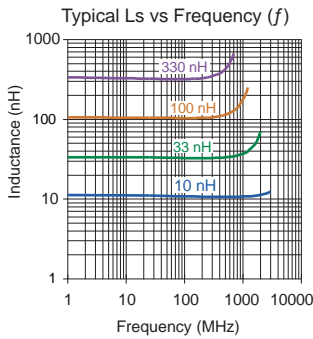

Single layer (typ)

Part No	Inductance		Tol	Q	f <sub>Q</sub>	SRF	DCR max	Rated DC Current
	L (nH)	f <sub>L</sub> (MHz)						
1206AS-3N3M-YY	3.3	100	20	30	300	6000 min	0.05	1000
1206AS-6N8K-YY	6.8	100	10	37	300	5500 min	0.07	1000
1206AS-010J-YY	10	100	5	40	300	4000 min	0.08	1000
1206AS-012J-YY	12	100	5	51	300	3200 min	0.08	1000
1206AS-015J-YY	15	100	5	51	300	3200 min	0.10	1000
1206AS-018J-YY	18	100	5	51	300	2800 min	0.10	1000
1206AS-022J-YY	22	100	5	52	300	2200 min	0.10	1000
1206AS-027J-YY	27	100	5	52	300	1800 min	0.11	1000
1206AS-030J-YY	30	100	5	52	300	1800 min	0.11	1000
1206AS-033J-YY	33	100	5	56	300	1800 min	0.11	1000
1206AS-039J-YY	39	100	5	64	300	1800 min	0.12	1000
1206AS-047J-YY	47	100	5	64	300	1500 min	0.13	1000
1206AS-056J-YY	56	100	5	64	300	1450 min	0.14	1000
1206AS-068J-YY	68	100	5	61	300	1200 min	0.26	900
1206AS-082J-YY	82	100	5	66	300	1200 min	0.21	900
1206AS-R10J-YY	100	100	5	55	300	1100 min	0.26	850
1206AS-R12J-YY	120	100	5	75	300	1100 min	0.26	800
1206AS-R13J-YY	130	100	5	75	300	950 min	0.31	750
1206AS-R15J-YY	150	100	5	65	300	950 min	0.31	750
1206AS-R18J-YY	180	50	5	75	300	900 min	0.43	700
1206AS-R21J-YY	210	50	5	75	300	760 min	0.50	670
1206AS-R22J-YY	220	50	5	75	300	760 min	0.50	670
1206AS-R24J-YY	240	50	5	57	300	730 min	0.56	630
1206AS-R27J-YY	270	50	5	57	300	730 min	0.56	630
1206AS-R29J-YY	290	50	5	57	150	650 min	0.62	590
1206AS-R33J-YY	330	50	5	55	150	650 min	0.62	590
1206AS-R39J-YY	390	50	5	55	150	600 min	0.75	530
1206AS-R47J-YY	470	50	5	52	150	550 min	1.30	490
1206AS-R50K-YY	500	50	10	45	150	470 typ	1.30	460
1206AS-R56K-YY	560	50	10	45	150	470 typ	1.34	460
1206AS-R68K-YY	680	35	10	45	150	450 typ	1.58	430
1206AS-R82K-YY	820	35	10	45	150	420 typ	1.82	400
1206AS-R91K-YY	910	35	10	45	150	416 typ	1.87	300
1206AS-1R0K-YY	1000	35	10	45	150	400 typ	2.80	320
1206AS-1R2K-YY	1200	35	10	45	150	380 typ	3.20	300
1206AS-2R2K-YY	2200	35	10	32	150	160 typ	4.50	280
1206AS-2R7K-YY	2700	35	10	25	50	160 typ	5.50	145
1206AS-3R3K-YY	3300	35	10	20	50	140 typ	6.50	130
1206AS-4R7K-YY	4700	35	10	20	50	120 typ	7.20	120

Core Material: Ceramic

Revision date: 13 Mar 2026

SPQ: Taped / Reel 1000 [-08]  
2000 [-01]  
7500 [-04]

Remarks: - Unlisted inductance values available upon request.  
- 2% and 5% tolerance available upon request.