

786071S
SJ120982
(ON DRAWING NO.)

版数 VER.	年月日 DATE	CN NO.	変更内容 DESCRIPTION	製図 DR.	担当 CHK.	査閲 APPD.	承認 APPD.
------------	-------------	--------	---------------------	-----------	------------	-------------	-------------

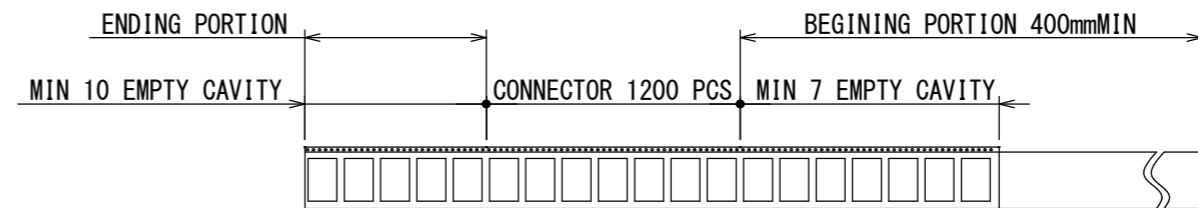
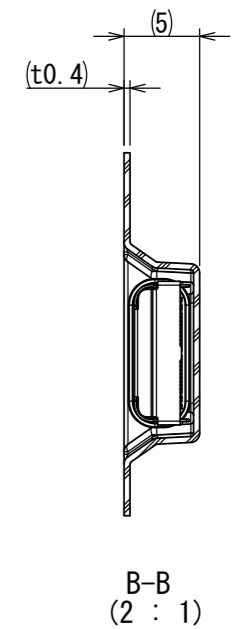
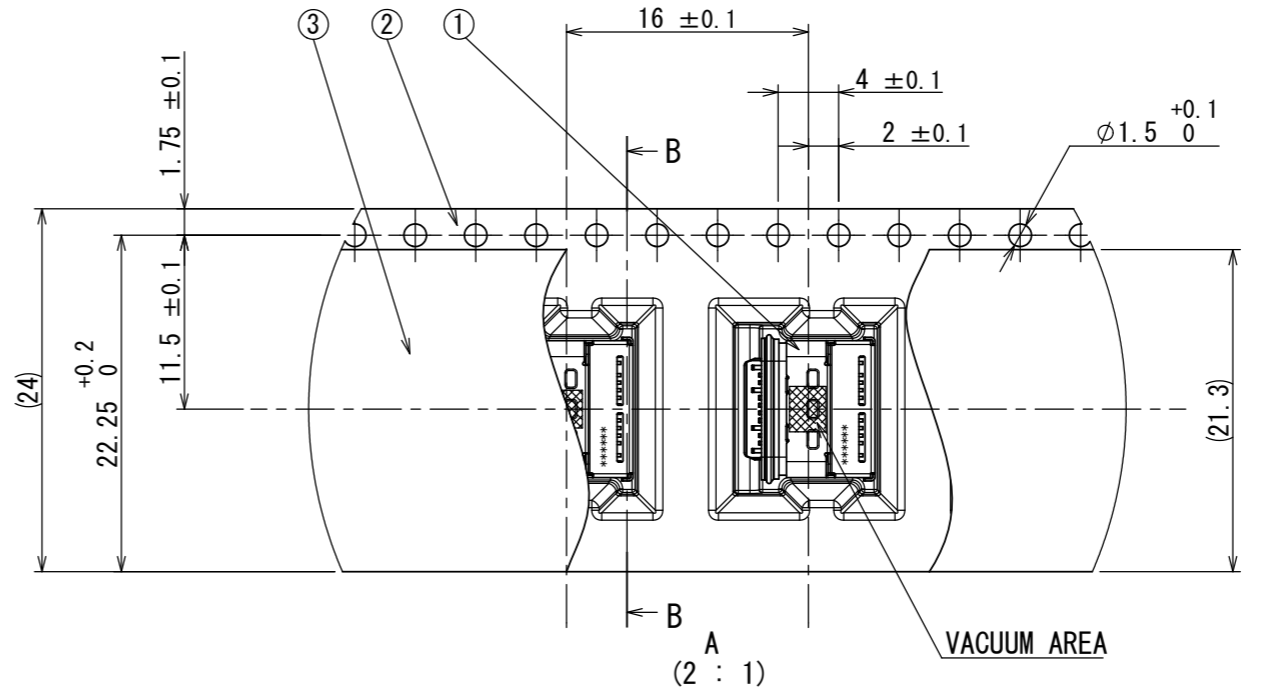
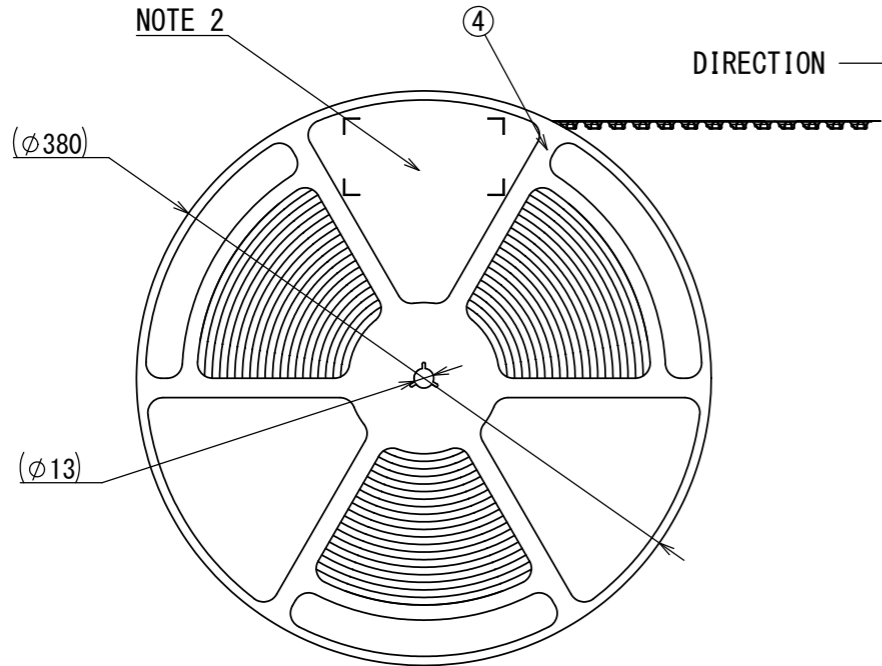

NOTE1. SUFFIX "R1200" OF PART NUMBER "DX07WH24JA3R1200" INDICATES 1200PCS IN REEL.
 2. THE LABEL IN WHICH DESCRIPTION, QTY, LOT NO, EMBOSS CODE AS INDICATED.
 3. REFER TO THE DRAWING "SJ120981 (DX07WH24JA3)" FOR THE CONNECTOR DIMENSIONS.
 4. REEL AND LABEL FORM MAY DIFFER FROM THE DRAWING.

R-Pb (Pb-Free)		COUNTRY OF MANUFACTURE	
台灣航空電子股份有限公司 MADE IN TAIWAN			
品名	DX07WH24JA3R1200		
収納数	1200	製造年月日	*****
備考	TB2416		
16: FEED PITCH		NUMBER OF CONNECTOR	
24: TAPE WIDTH		LOT NUMBER	

4	REEL	1	PS	-	-
3	COVER TAPE	1	PET	-	-
2	CARRIER TAPE	1	PS	-	-
1	DX07WH24JA3	1200	-	-	SJ120981
符号 NO.	名称 DESCRIPTION	個数 QTY.	材料 MATERIAL	仕上 FINISH	備考 REMARKS

仕様書 (SPECIFICATION) JACS-30353-24		第1版 (ORIGINAL DATE) 11/SEP/2018		尺度 (SCALE) 1:5		シリーズ (SERIES) DX07		日本航空電子工業株式会社	
一般公差 (GENERAL TOLERANCE)		製図 DR.		名称 (TITLE) DX07WH24JA3R1200		JAE		JAPAN AVIATION ELECTRONICS INDUSTRY, LTD.	
寸法 (DIMENSION)		担当 CHK.		質量 (MASS)		図面番号 (DRAWING NO.) SJ120982		版数 (VER.) 1	
角度 (ANGLES)		査閲 APPD.		Y. YOKOYAMA		承認 APPD.		Y. SAITOU	
単位 (UNIT) : mm		承認 APPD.		Y. SAITOU		S/W			

DCF-G-212H(12.08)

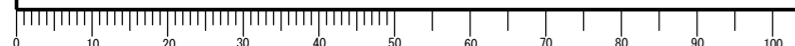

WISDOM承認 2018/09/13