

**PRODUCT / PROCESS CHANGE NOTIFICATION**

**1. PCN basic data**

<b>1.1 Company</b>		STMicroelectronics International N.V
<b>1.2 PCN No.</b>	AMS/21/12868	
<b>1.3 Title of PCN</b>	Introduction of subcontractor TSHT for Standard General Purpose Analog products assembled in MiniSO8 (HCMOS7 and BiCMOS40 Technologies)	
<b>1.4 Product Category</b>	See product list	
<b>1.5 Issue date</b>	2021-06-21	

**2. PCN Team**

<b>2.1 Contact supplier</b>	
<b>2.1.1 Name</b>	ROBERTSON HEATHER
<b>2.1.2 Phone</b>	+1 8475853058
<b>2.1.3 Email</b>	heather.robertson@st.com
<b>2.2 Change responsibility</b>	
<b>2.2.1 Product Manager</b>	Marcello SAN BIAGIO
<b>2.1.2 Marketing Manager</b>	Salvatore DI VINCENZO
<b>2.1.3 Quality Manager</b>	Jean-Marc BUGNARD

**3. Change**

<b>3.1 Category</b>	<b>3.2 Type of change</b>	<b>3.3 Manufacturing Location</b>
Transfer	Line transfer for a full process or process brick (process step, control plan, recipes) from one site to another site: Assembly site (SOP 2617)	TSHT China

**4. Description of change**

	<b>Old</b>	<b>New</b>
<b>4.1 Description</b>	Assembly plant : - Amkor Philippines	Assembly plant : - Amkor Philippines - TSHT China
<b>4.2 Anticipated Impact on form,fit, function, quality, reliability or processability?</b>	No impact	

**5. Reason / motivation for change**

<b>5.1 Motivation</b>	Progressing on activities related to process modernization and quality improvement, ST is pleased to announce the introduction of TSHT/China as an added subcontractor for Assy and Test & Finishing activities for selected products assembled in MiniSO8 package.
<b>5.2 Customer Benefit</b>	SERVICE IMPROVEMENT

**6. Marking of parts / traceability of change**

<b>6.1 Description</b>	New Finished good codes
------------------------	-------------------------

**7. Timing / schedule**

<b>7.1 Date of qualification results</b>	2021-06-17
<b>7.2 Intended start of delivery</b>	2021-06-30
<b>7.3 Qualification sample available?</b>	Upon Request

**8. Qualification / Validation**

<b>8.1 Description</b>	12868 Qual report MiniSO TSHT-H7 BiCMOS40.pdf		
<b>8.2 Qualification report and qualification results</b>	Available (see attachment)	<b>Issue Date</b>	2021-06-21

**9. Attachments (additional documentations)**

12868 Public product.pdf  
 12868 Qual report MiniSO TSHT-H7 BiCMOS40.pdf

**10. Affected parts**

10. 1 Current		10.2 New (if applicable)
10.1.1 Customer Part No	10.1.2 Supplier Part No	10.1.2 Supplier Part No
	OA2MPA34S	
	OA2ZHA34S	
	STM6904PWEDS6F	
	STM6904SYEDS6F	
	STM6904TGEDS6F	
	STM6904TWEDS6F	
	STM6904TZEDS6F	
	STM6905PWEDS6F	
	STM6905SFEDS6F	
	STM6905SYEDS6F	
	STM6905TGEDS6F	
	STM6905TWEDS6F	
	STM6905TZEDS6F	
	STM704SDS6F	
STM706DS6F	STM706DS6F	
STM708SDS6F	STM708SDS6F	
STM708TDS6F	STM708TDS6F	
	STMPS2141TTR	
	STMPS2151TTR	
	STMPS2161TTR	
	STMPS2171TTR	
	STMPS2252TTR	
	STMPS2262TTR	
	STMPS2272TTR	
TS419IST	TS419IST	
TS482IST	TS482IST	
TS4871IST	TS4871IST	
TS4890IST	TS4890IST	
TS4990IST	TS4990IST	
TS4994IST	TS4994IST	
	TSB572IST	
	TSB712AIST	
	TSB712IST	
	TSB7192AIST	
	TSB7192IST	
	TSU112IST	
	TSV712IST	
	TSV732IST	
	TSX712IST	
	TSX7192IST	
	TSZ122IST	
	TSZ182IST	

**IMPORTANT NOTICE – PLEASE READ CAREFULLY**

Subject to any contractual arrangement in force with you or to any industry standard implemented by us, STMicroelectronics NV and its subsidiaries (“ST”) reserve the right to make changes, corrections, enhancements, modifications, and improvements to ST products and/or to this document at any time without notice. Purchasers should obtain the latest relevant information on ST products before placing orders. ST products are sold pursuant to ST’s terms and conditions of sale in place at the time of order acknowledgement.

Purchasers are solely responsible for the choice, selection, and use of ST products and ST assumes no liability for application assistance or the design of Purchasers’ products.

No license, express or implied, to any intellectual property right is granted by ST herein.

Resale of ST products with provisions different from the information set forth herein shall void any warranty granted by ST for such product.

ST and the ST logo are trademarks of ST. All other product or service names are the property of their respective owners.

Information in this document supersedes and replaces information previously supplied in any prior versions of this document.

© 2018 STMicroelectronics – All rights reserved



## Public Products List

Public Products are off the shelf products. They are not dedicated to specific customers, they are available through ST Sales team, or Distributors, and visible on ST.com

**PCN Title :** Introduction of subcontractor TSHT for Standard General Purpose Analog products assembled in MiniSO8 (HCMOS7 and BiCMOS40 Technologies)

**PCN Reference :** AMS/21/12868

**Subject :** Public Products List

Dear Customer,

Please find below the Standard Public Products List impacted by the change.

TSV712IST	STM6905TZEDS6F	STMPS2141TTR
TSU112IST	STM708TDS6F	STMPS2262TTR
TS482IST	TS4990IST	TS4871IST
STM704SDS6F	STMPS2171TTR	STMPS2242TTR
STM6905TWEDS6F	STM6904SFEDS6F	TS419IST
TS4994IST	STMPS2272TTR	TSZ182IST
TS4890IST	TSB712AIST	TSX7192IST
TSB572IST	STM6904PWEDS6F	STM708SDS6F
STM6905SYEDS6F	STM6905TGEDS6F	TSB7192IST
OA2ZHA34S	STMPS2151TTR	STM6904TZEDS6F
TSZ122IST	STM706DS6F	TSV732IST
TSB7192AIST	TSB712IST	STM6904TWEDS6F
TSX712IST	STM6905PWEDS6F	STM6904TGEDS6F
STMPS2252TTR	STMPS2161TTR	STM6904SYEDS6F
STM6905SFEDS6F		



### IMPORTANT NOTICE – PLEASE READ CAREFULLY

Subject to any contractual arrangement in force with you or to any industry standard implemented by us, STMicroelectronics NV and its subsidiaries (“ST”) reserve the right to make changes, corrections, enhancements, modifications, and improvements to ST products and/or to this document at any time without notice. Purchasers should obtain the latest relevant information on ST products before placing orders. ST products are sold pursuant to ST’s terms and conditions of sale in place at the time of order acknowledgement.

Purchasers are solely responsible for the choice, selection, and use of ST products and ST assumes no liability for application assistance or the design of Purchasers’ products.

No license, express or implied, to any intellectual property right is granted by ST herein.

Resale of ST products with provisions different from the information set forth herein shall void any warranty granted by ST for such product.

ST and the ST logo are trademarks of ST. All other product or service names are the property of their respective owners.

Information in this document supersedes and replaces information previously supplied in any prior versions of this document.



**PRODUCT/PROCESS  
CHANGE NOTIFICATION**

---

PCN AMS/21/12833

---



**Analog, MEMS & Sensors (AMS)**

**Introduction of subcontractor TSHT  
for selected General Purpose Analog products assembled in  
MiniSO8 (HCMOS7 and BiCMOS40 Technologies)**

**WHAT:**

Progressing on activities related to process modernization and quality improvement, ST is pleased to announce the introduction of TSHT/China as an added subcontractor for Assembly and Test & Finishing activities for selected products assembled in MiniSO8 package..

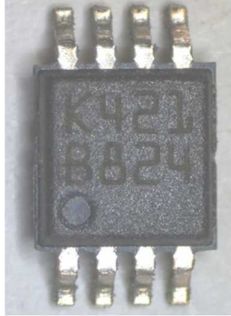
Please find more information related to material change in the table here below

Material	Current process	Modified process	Comment
Diffusion location	ST Ang Mo Kio (Singapore)/ UMC / ST Agrate	ST Ang Mo Kio (Singapore)/ UMC / ST Agrate	
Assembly location	Amkor Philippines	TSHT China	
Molding compound	Sumitomo G700	Hitachi CEL 9220	
Die attach	Henkel 8290	Henkel 8200T/Henkel8600	
Leadframe	Copper	Copper	
Plating	NiPdAu	Matte Sn	
Wire	Gold 0.8Mil	Copper Pd coated 1 mil	
Appearance			

**WHY:**

The purpose of the introduction of TSHT for both Assy and Test & Finishing activities is to further improve the rationalization of our manufacturing assets and provide a better support to our customers by enhancing the manufacturing process for higher volume production.

**HOW:**

The qualification program consists mainly of comparative electrical characterization and reliability tests.

You will find here after the qualification test plan which summarizes the various test methods and conditions that ST uses for this qualification program.

**WHEN:**

The new material set will be implemented in Q3/2021 in TSHT China.



### **Marking and traceability:**

Unless otherwise stated by customer's specific requirement, the traceability of the parts assembled with the new material set will be ensured by new internal sales type, date code and lot number.

The changes here reported will not affect the electrical, dimensional and thermal parameters keeping unchanged all the information reported on the relevant datasheets.

There is -as well- no change in the packing process or in the standard delivery quantities. Shipments may start earlier with the customer's written agreement.





**Reliability Qualification plan**  
*AMS Back-end qualification*  
**MSOP 8**  
*Production transfer to TSHT*

General Information	
<b>Product Line</b>	<i>0193, 0358, V992, UY32, VB2F, A256</i>
<b>Product Description</b>	Dual comparator bipolar, Dual op amp bipolar, , Dual op amp, biCMOS, Dual precision op amp, 4 A dual low-side, High bandwidth (50MHz) Low offset (250µV) Op amp, Dual op amp
<b>P/N</b>	<i>LM2903WYST, LM2904WYST, TSV992IYST, TSX922IYST, TSV792IYST, TSB612IYST</i>
<b>Product Group</b>	<i>AMS</i>
<b>Product division</b>	<i>General Purpose Analog &amp;RF</i>
<b>Package</b>	<i>MiniSO8</i>
<b>Silicon Process technology</b>	<i>Bipolar, HF5CMOS, HVG8A, HCMOS7, BiCMOS40</i>

Locations	
<b>Wafer fab</b>	<i>ST Singapore UMC, ST Agrate, ST Crolles</i>
<b>Assembly plant</b>	<i>TSHT China</i>
<b>Reliability Lab</b>	<i>ST Grenoble, TSHT</i>

Note: This report is a summary of the reliability trials performed in good faith by STMicroelectronics in order to evaluate the potential reliability risks during the product life using a set of defined test methods.

This report does not imply for STMicroelectronics expressly or implicitly any contractual obligations other than as set forth in STMicroelectronics general terms and conditions of Sale. This report and its contents shall not be disclosed to a third party without previous written agreement from STMicroelectronics.



**TABLE OF CONTENTS**

**1 APPLICABLE AND REFERENCE DOCUMENTS..... 10**  
**2 GLOSSARY ..... 10**  
**3 RELIABILITY EVALUATION OVERVIEW ..... 10**  
    3.1 OBJECTIVES..... 10  
    3.2 CONCLUSION ..... 10  
**4 DEVICE CHARACTERISTICS ..... 11**  
    4.1 DEVICE DESCRIPTION ..... 11  
    4.2 CONSTRUCTION NOTE..... 16  
**5 TESTS PLAN SUMMARY ..... 17**  
    5.1 TEST VEHICLE ..... 17  
    5.2 TEST PLAN SUMMARY ..... 17  
**6 ANNEXES ..... 18**  
    6.1 TESTS DESCRIPTION ..... 18

## **1 APPLICABLE AND REFERENCE DOCUMENTS**

<b>Document reference</b>	<b>Short description</b>
<b>JESD47</b>	Stress-Test-Driven Qualification of Integrated Circuits

## **2 GLOSSARY**

<b>DUT</b>	Device Under Test
<b>PCB</b>	Printed Circuit Board
<b>SS</b>	Sample Size

## **3 RELIABILITY EVALUATION OVERVIEW**

### **3.1 Objectives**

To qualify a new assembly site, TSHT China, for products in MiniSO8 package for Analog standard products.

### **3.2 Conclusion**

Qualification Plan requirements have to be fulfilled without issue. It is stressed that reliability tests have to show that the devices behave correctly against environmental tests (no failure). Moreover, the stability of electrical parameters during the accelerated tests have to demonstrate the ruggedness of the products and safe operation, which is consequently expected during their lifetime.

## 4 DEVICE CHARACTERISTICS

### 4.1 Device description

LM2903WST



LM2903W

Low-power, dual-voltage comparator

Datasheet – production data

#### Features

- Wide, single supply voltage range or dual supplies +2 V to +36 V or  $\pm 1$  V to  $\pm 18$  V
- Very low supply current (0.4 mA) independent of supply voltage (1 mW/comparator at +5 V)
- Low input bias current: 25 nA typ.
- Low input offset current:  $\pm 5$  nA typ.
- Input common-mode voltage range includes negative rail
- Low output saturation voltage: 250 mV typ. ( $I_O = 4$  mA)
- Differential input voltage range equal to the supply voltage
- TTL, DTL, ECL, MOS, CMOS compatible outputs
- ESD internal protection: 2 kV

#### Description

This device consists of two independent low-power voltage comparators designed specifically to operate from a single supply over a wide range of voltages. Operation from split power supplies is also possible.

The input common-mode voltage range includes negative rail even though operated from a single power supply voltage.

All pins are protected against electrostatic discharge up to 2 kV. Consequently, the input voltages must not exceed the  $V_{CC}^+$  or  $V_{CC}^-$  magnitudes.

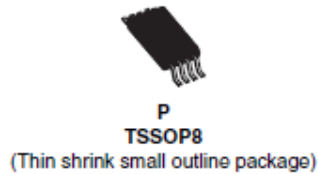

#### Pin connections (top view)

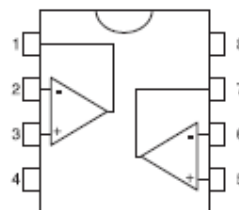

- 1 - Output 1
- 2 - Inverting input 1
- 3 - Non-inverting input 1
- 4 -  $V_{CC}^-$
- 5 - Non-inverting input 2
- 6 - Inverting input 2
- 7 - Output 2
- 8 -  $V_{CC}^+$

LM2904WST,



**LM2904, LM2904A**  
**LM2904W, LM2904AW**  
 Datasheet

Low-power dual operational amplifier



**Features**

- Frequency compensation implemented internally
- Large DC voltage gain: 100 dB
- Wide bandwidth (unity gain): 1.1 MHz (temperature compensated)
- Very low supply current/amplifier, essentially independent of supply voltage
- Low input bias current: 20 nA (temperature compensated)
- Low input offset current: 2 nA
- Input common-mode voltage range includes negative rail
- Differential input voltage range equal to the power supply voltage
- Large output voltage swing 0 V to  $[(V_{CC}^+) - 1.5 V]$

**Description**

This circuit consists of two independent, high gain operational amplifiers (op amps) that have frequency compensation implemented internally. They are designed specifically for automotive and industrial control systems. The circuit operates from a single power supply over a wide range of voltages. The low power supply drain is independent of the magnitude of the power supply voltage.

Application areas include transducer amplifiers, DC gain blocks and all the conventional op amp circuits which can now be more easily implemented in single power supply systems. For example, these circuits can be directly supplied from the standard 5 V which is used in logic systems and easily provides the required electronic interfaces without requiring any additional power supply.

In linear mode, the input common-mode voltage range includes ground and the output voltage can also swing to ground, even though operated from a single power supply.

Maturity status link		
	Enhanced V <sub>IO</sub>	Enhanced ESD
LM2904		
LM2904A	✓	
LM2904W		✓
LM2904AW	✓	✓

Related products	
TSB572	Dual op-amps for low-power consumption (380 µA with 2.5 MHz GBP)
LM2902 LM2902W	Quad op-amps version
LM2904WH LM2904AH	High temperature version (150 °C)

TSV992IST



**TSV991, TSV992, TSV994 TSV991A  
TSV992A, TSV994A**  
Datasheet

Rail-to-rail input/output 20 MHz GBP operational amplifiers

Pin connections  
(top view)

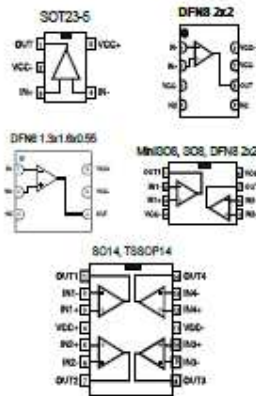

**Features**

- Low input offset voltage: 1.5 mV max. (A grade)
- Rail-to-rail input and output
- Wide bandwidth 20 MHz
- Stable for gain  $\geq 4$  or  $\leq -3$
- Low power consumption: 820  $\mu$ A typ.
- High output current: 35 mA
- Operating from 2.5 V to 5.5 V
- Low input bias current, 1 pA typ.
- ESD internal protection  $\geq 5$  kV

**Applications**

- Battery-powered applications
- Portable devices
- Signal conditioning and active filtering
- Medical instrumentation
- Automotive applications

**Description**

The TSV99x and TSV99xA family of single, dual, and quad operational amplifiers offers low voltage operation and rail-to-rail input and output. These devices feature an excellent speed/power consumption ratio, offering a 20 MHz gain-bandwidth, stable for gains above 4 (100 pF capacitive load), while consuming only 1.1 mA maximum at 5 V. They also feature an ultra-low input bias current. These characteristics make the TSV99x family ideal for sensor interfaces, battery-supplied and portable applications, as well as active filtering. These characteristics make the TSV99x, TSV99xA family ideal for sensor interfaces, battery-supplied and portable applications, as well as active filtering.

Product status link	
<a href="#">TSV991, TSV992, TSV994, TSV991A, TSV992A, TSV994A</a>	
Related products	
See <a href="#">TSV911, TSV912, TSV914, TSV911A, TSV912A, TSV914A</a>	For unity-gain stable amplifiers

TSX922IST

# TSX920, TSX921, TSX922, TSX923

## 10 MHz rail-to-rail CMOS 16 V operational amplifiers

Datasheet - production data

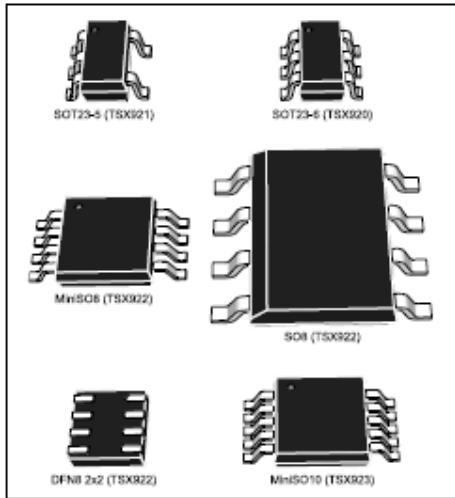

### Applications

- Communications
- Process control
- Test equipment

### Description

The TSX92x single and dual operational amplifiers (op amps) offer excellent AC characteristics such as 10 MHz gain bandwidth, 17 V/ms slew rate, and 0.0003 % THD+N. These features make the TSX92x family particularly well-adapted for communications, I/V amplifiers for ADCs, and active filtering applications.

Their rail-to-rail input and output capability, while operating on a wide supply voltage range of 4 V to 16 V, allows these devices to be used in a wide range of applications. Automotive qualification is available as these devices can be used in this market segment.

Shutdown mode is available on the single (TSX920) and dual (TSX923) versions enabling an important current consumption reduction while this function is active.

The TSX92x family is available in SMD packages featuring a high level of integration. The DFN8 package, used in the TSX922, with a typical size of 2x2 mm and a maximum height of 0.8 mm offers even greater package size reduction.

### Features

- Rail-to-rail input and output
- Wide supply voltage: 4 V - 16 V
- Gain bandwidth product: 10 MHz typ at 16 V
- Low power consumption: 2.8 mA typ per amplifier at 16 V
- Unity gain stable
- Low input bias current: 10 pA typ
- High tolerance to ESD: 4 kV HBM
- Extended temperature range: -40 °C to 125 °C
- Automotive qualification

Table 1: Device summary

Op-amp version	With shutdown mode	Without shutdown mode
Single	TSX920	TSX921
Dual	TSX923	TSX922

### Related products

- See the TSX5 series for low-power features
- See the TSX6 series for micro-power features
- See the TSX929 series for higher speeds
- See the TSV9 series for lower voltages

TSV792IST



TSV791, TSV792

Datasheet

High bandwidth (50 MHz) low offset (200  $\mu$ V) rail-to-rail 5 V op-amp



Features

- Gain bandwidth product 50 MHz, unity gain stable
- Slew rate 30 V/ $\mu$ s
- Low input offset voltage 50  $\mu$ V typ., 200  $\mu$ V max.
- Low input bias current: 2 pA typ.
- Low input voltage noise density 5 nV/ $\sqrt$ Hz @ 10 kHz
- Wide supply voltage range: 2.2 V to 5.5 V
- Rail-to-rail input and output
- Extended temperature range: - 40  $^{\circ}$ C to +125  $^{\circ}$ C
- Automotive grade version available
- Benefits:
  - Accuracy of measurement virtually unaffected by noise or input bias current
  - Signal conditioning for high frequencies

Applications

- High bandwidth low-side and high-side current sensing
- Photodiode transimpedance amplification
- A/D converters input buffers
- Power management in solar-powered systems
- Power management in automotive applications

Maturity status link	
TSV791, TSV792	
Related products	
TSZ181 TSZ182	Zero drift amplifiers with more power savings (3 MHz)
TSB712	36 V high-bandwidth amplifiers (6 MHz)
TSB7192	36 V high-bandwidth amplifiers (20 MHz)

Description

The TSV791 and TSV792 are single and dual 50 MHz-bandwidth unity-gain-stable amplifiers. The rail-to-rail input stage and the slew rate of 30 V/ $\mu$ s make the TSV791 and TSV792 ideal for low-side current measurement. The excellent accuracy provided by maximum input voltage of 200  $\mu$ V allows amplifying accurately small-amplitude input signal. The TSV792 can operate from a 2.2 V to 5.5 V single supply it can typically handle an output capacitor up to 1 nF and is fully specified on a load of 22 pF, therefore allowing easy usage as A/D converters input buffer.



## 4.2 Construction note

	P/N <i>LM2903WST</i>	P/N <i>LM2904WST</i>	P/N <i>TSV9921ST</i>
Wafer fab manufacturing location	ST Singapore	ST Singapore	ST Singapore
Technology	Bipolar	Bipolar	HF5CMOS
Die finishing back side	RAW SILICON	RAW SILICON	LAPPED SILICON
Die size (microns)	1120x1050	1280x1210	1070x1100
Bond pad metallization layers	AlSiCu	AlSiCu	AlCu
Passivation type	Nitride	Nitride	PSG + NITRIDE
Electrical testing manufacturing location	ST Singapore	ST Singapore	ST Singapore
Assembly site	TSHT	TSHT	TSHT
Package description	MiniSO8	MiniSO8	MiniSO8
Molding compound	Hitachi CEL-9220	Hitachi CEL-9220	Hitachi CEL-9220
Frame material	Cu	Cu	Cu
Die attach process	Epoxy Glue	Epoxy Glue	Epoxy Glue
Die attach material	Henkel 8200T	Henkel 8200T	Henkel 8200T
Wire bonding process	Thermosonic ball bonding	Thermosonic ball bonding	Thermosonic ball bonding
Wires bonding materials/diameters	Cu 1 mil Pd Coated	Cu 1 mil Pd Coated	Cu 1 mil Pd Coated
Lead finishing process	electroplating	electroplating	electroplating
Lead finishing/bump solder material	Matte Sn	Matte Sn	Matte Sn
<b>Final testing information</b>			
Testing location	TSHT	TSHT	TSHT

	P/N <i>TSX9221ST</i>	P/N <i>TSV7921ST</i>	P/N <i>TSB6121YST</i>
Wafer fab manufacturing location	UMC Taiwan	ST Crolles	ST Singapore
Technology	HVG8A	HCMOS7A	BiCMOS40
Die finishing back side	LAPPED SILICON	RAW SILICON	RAW SILICON
Die size (microns)	1700x1400	938x1638	1618x1656
Bond pad metallization layers	AlCu	AlCu	AlSiCu
Passivation type	PSG + NITRIDE	PSG + NITRIDE + PIX	PSG + NITRIDE
Electrical testing manufacturing location	ST Singapore	ST Singapore	ST Singapore
Assembly site	TSHT	TSHT	TSHT
Package description	MiniSO8	MiniSO8	MiniSO8
Molding compound	Hitachi CEL-9220	Hitachi CEL-9220	Hitachi CEL-9220
Frame material	Cu	Cu	Cu
Die attach process	Epoxy Glue	Epoxy Glue	Epoxy Glue
Die attach material	Henkel 8200T	Henkel 8200T	Henkel 8200T
Wire bonding process	Thermosonic ball bonding	Thermosonic ball bonding	Thermosonic ball bonding
Wires bonding materials/diameters	Cu 1 mil Pd Coated	Cu 0.8 mil Pd Coated	Cu 0.8 mil Pd Coated
Lead finishing process	electroplating	electroplating	electroplating
Lead finishing/bump solder material	Matte Sn	Matte Sn	Matte Sn
<b>Final testing information</b>			
Testing location	TSHT	TSHT	TSHT



## 5 TESTS PLAN SUMMARY

### 5.1 Test vehicle

Lot #	Process/ Package	Product Line	Comments
1	Bipolar/MiniSO8	0193	
2	Bipolar/MiniSO8	0358	
3	HF5CMOS/MiniSO8	V992	
4	HVG8A/MiniSO8	UY32	
5	HCMOS7A/MiniSO8	VB2F	
6	BiCMOS40/MiniSO8	A256	

### 5.2 Test plan summary

Test	PC	Std ref.	Conditions	SS	Steps	Failure/SS						Note
						Lot 1 0193	Lot 2 0358	Lot3 V992	Lot 4 UY32	Lot 5 VB2F	Lot 6 A256	
HTB/ HTOL	N	JESD22 A-108	Ta = 125°C or 150°C, BIAS		168 H	0/77	0/77	0/77	0/77	0/77	0/77	Lot 1, 2 at 150°C
					500 H	0/77	0/77	0/77	0/77	0/77		
					1000 H	0/77	0/77	0/77	0/77	0/77		
ELFR	N	JESD22 A-008	Ta = 150°C or 150°C, BIAS		48H	0/800	0/800	0/800				
HTSL	N	JESD22 A-103	Ta = 150°C		168 H	2x0/50	3x0/50	2x0/50	2x0/50	0/77		
					500 H	2x0/50	3x0/50	2x0/50	2x0/50	0/77		
					1000 H	2x0/50	3x0/50	2x0/50	2x50	0/77		
					1500H		0/50			0/77		
					2000H		0/50			0/77		
PC		JESD22 A-113	Drying 24 H @ 125°C Store 168 H @ Ta=85°C Rh=85% Over Reflow @ Tpeak=260°C 3 times		Final	PASS	PASS	PASS	PASS	PASS	PASS	
UHAST	Y	JESD22 A-102	85%RH / Ta=130°C		96 H	2x0/77	3X0/77	2X0/77	0/77	0/77		
TC	Y	JESD22 A-104	Ta = -55°C to 150°C		100 cy	2x0/77	3x0/77	2x0/77	2x0/77	0/77		
					200cy	2x0/77	3x0/77	2x0/77	2x0/77	0/77		
					500 cy	2x0/77	3x0/77	2x0/77	2x0/77	0/77		
					1000cy	2x0/77	3x0/77	2x0/77	2x77	0/77		
					3000cy		0/77					
THB	Y	JESD22 A-101	Ta = 85°C, RH = 85%, BIAS		168 H	0/77	0/77	0/77	0/77	0/77		
					500 H	0/77	0/77	0/77	0/77	0/77		
					1000 H	0/77	0/77	0/77	0/77	0/77		
					2000H	0/77	0/77			0/77		

## 6 ANNEXES

### 6.1 Tests Description

Test name	Description	Purpose
<b>Die Oriented</b>		
<b>HTOL</b> High Temperature Operating Life  <b>HTB</b> High Temperature Bias	The device is stressed in static or dynamic configuration, approaching the operative max. absolute ratings in terms of junction temperature and bias condition.	To determine the effects of bias conditions and temperature on solid state devices over time. It simulates the devices' operating condition in an accelerated way.  The typical failure modes are related to, silicon degradation, wire-bonds degradation, oxide faults.
<b>HTRB</b> High Temperature Reverse Bias  <b>HTFB / HTGB</b> High Temperature Forward (Gate) Bias	The device is stressed in static configuration, trying to satisfy as much as possible the following conditions: low power dissipation; max. supply voltage compatible with diffusion process and internal circuitry limitations;	To determine the effects of bias conditions and temperature on solid state devices over time. It simulates the devices' operating condition in an accelerated way.  To maximize the electrical field across either reverse-biased junctions or dielectric layers, in order to investigate the failure modes linked to mobile contamination, oxide ageing, layout sensitivity to surface effects.
<b>HTSL</b> High Temperature Storage Life	The device is stored in unbiased condition at the max. temperature allowed by the package materials, sometimes higher than the max. operative temperature.	To investigate the failure mechanisms activated by high temperature, typically wire-bonds solder joint ageing, data retention faults, metal stress-voiding.
<b>ELFR</b> Early Life Failure Rate	The device is stressed in biased conditions at the max junction temperature.	To evaluate the defects inducing failure in early life.
<b>Package Oriented</b>		
<b>PC</b> Preconditioning	The device is submitted to a typical temperature profile used for surface mounting devices, after a controlled moisture absorption.	As stand-alone test: to investigate the moisture sensitivity level.  As preconditioning before other reliability tests: to verify that the surface mounting stress does not impact on the subsequent reliability performance.  The typical failure modes are "pop corn" effect and delamination.
<b>AC</b> Auto Clave (Pressure Pot)	The device is stored in saturated steam, at fixed and controlled conditions of pressure and temperature.	To investigate corrosion phenomena affecting die or package materials, related to chemical contamination and package hermeticity.
<b>TC</b> Temperature Cycling	The device is submitted to cycled temperature excursions, between a hot and a cold chamber in air atmosphere.	To investigate failure modes related to the thermo-mechanical stress induced by the different thermal expansion of the materials interacting in the die-package system. Typical failure modes are linked to metal displacement, dielectric cracking, molding compound delamination, wire-bonds failure, die-attach layer degradation.



Test name	Description	Purpose
<b>TF / IOL</b> Thermal Fatigue / Intermittent Operating Life	The device is submitted to cycled temperature excursions generated by power cycles (ON/OFF) at T ambient.	To investigate failure modes related to the thermo-mechanical stress induced by the different thermal expansion of the materials interacting in the die-package system. Typical failure modes are linked to metal displacement, dielectric cracking, molding compound delamination, wire-bonds failure, die-attach layer degradation.
<b>THB</b> Temperature Humidity Bias	The device is biased in static configuration minimizing its internal power dissipation, and stored at controlled conditions of ambient temperature and relative humidity.	To evaluate the package moisture resistance with electrical field applied, both electrolytic and galvanic corrosion are put in evidence.
<b>Other</b>		
<b>ESD</b> Electro Static Discharge	The device is submitted to a high voltage peak on all his pins simulating ESD stress according to different simulation models. CBM: Charged Device Model HBM: Human Body Model MM: Machine Model	To classify the device according to his susceptibility to damage or degradation by exposure to electrostatic discharge.
<b>LU</b> Latch-Up	The device is submitted to a direct current forced/sunk into the input/output pins. Removing the direct current no change in the supply current must be observed.	To verify the presence of bulk parasitic effect inducing latch-up.