

PRODUCT / PROCESS CHANGE NOTIFICATION

1. PCN basic data

1.1 Company		STMicroelectronics International N.V
1.2 PCN No.	POWER AND DISCRETE PRODUCTS/24/14700	
1.3 Title of PCN	Transfer of Assembly and Test line for TVS products housed in SMA & SMB packages	
1.4 Product Category	SMAJxxx SM6Txxx SMBJxxx	
1.5 Issue date	2024-04-15	

2. PCN Team

2.1 Contact supplier	
2.1.1 Name	ROBERTSON HEATHER
2.1.2 Phone	+1 8475853058
2.1.3 Email	heather.robertson@st.com
2.2 Change responsibility	
2.2.1 Product Manager	Stephane CHAMARD
2.1.2 Marketing Manager	Philippe LEGER
2.1.3 Quality Manager	Jean-Paul REBRASSE

3. Change

3.1 Category	3.2 Type of change	3.3 Manufacturing Location
Transfer	Line transfer for a full process or process brick (process step, control plan, recipes) from one site to another site: Wafer fabrication (SOP 2617)	Same subcontractor in China (same city)

4. Description of change

	Old	New
4.1 Description	Subcontractor A - Plant 1 in China	Subcontractor A - Plant 2 in China
4.2 Anticipated Impact on form,fit, function, quality, reliability or processability?	No	

5. Reason / motivation for change

5.1 Motivation	Due to plant rationalization at subcontractor level, STMicroelectronics started new plant qualification to support TVS products business continuity.
5.2 Customer Benefit	SERVICE CONTINUITY

6. Marking of parts / traceability of change

6.1 Description	New Finished Good/Type (ending by /HR) print on carton labels
------------------------	---

7. Timing / schedule

7.1 Date of qualification results	2024-04-12
7.2 Intended start of delivery	2024-07-19
7.3 Qualification sample available?	Upon Request

8. Qualification / Validation

8.1 Description	14700 24014QRP.pdf		
8.2 Qualification report and qualification results	Available (see attachment)	Issue Date	2024-04-15

9. Attachments (additional documentations)

14700 Public product.pdf
 14700 PCN TVS plant transfer at subco.pdf
 14700 24014QRP.pdf

10. Affected parts

10. Affected parts		
10.1 Current		10.2 New (if applicable)
10.1.1 Customer Part No	10.1.2 Supplier Part No	10.1.2 Supplier Part No
SM6T15A	SM6T15A	
SM6T15CA	SM6T15CA	
SM6T18A	SM6T18A	
SM6T18CA	SM6T18CA	
SM6T22A	SM6T22A	
SM6T22CA	SM6T22CA	
SM6T24A	SM6T24A	
SM6T24CA	SM6T24CA	
SM6T27A	SM6T27A	
SM6T27CA	SM6T27CA	
SM6T30A	SM6T30A	
SM6T30CA	SM6T30CA	
SM6T33A	SM6T33A	
SM6T33CA	SM6T33CA	
SM6T36A	SM6T36A	
SM6T36CA	SM6T36CA	
SM6T39A	SM6T39A	
SM6T39CA	SM6T39CA	
SM6T56CA	SM6T56CA	
SM6T68CA	SM6T68CA	
SMAJ12A-TR	SMAJ12A-TR	
SMAJ12CA-TR	SMAJ12CA-TR	
SMAJ13A-TR	SMAJ13A-TR	
SMAJ13CA-TR	SMAJ13CA-TR	
SMAJ15A-TR	SMAJ15A-TR	
SMAJ15CA-TR	SMAJ15CA-TR	
SMAJ18A-TR	SMAJ18A-TR	
SMAJ18CA-TR	SMAJ18CA-TR	
	SMAJ20A-TR	
SMAJ24A-TR	SMAJ24A-TR	
	SMAJ24CA-TR	
SMAJ26A-TR	SMAJ26A-TR	
	SMAJ26CA-TR	
SMAJ28A-TR	SMAJ28A-TR	
SMAJ28CA-TR	SMAJ28CA-TR	
SMAJ30A-TR	SMAJ30A-TR	
SMAJ30CA-TR	SMAJ30CA-TR	
SMAJ33A-TR	SMAJ33A-TR	
SMAJ33CA-TR	SMAJ33CA-TR	
SMAJ40CA-TR	SMAJ40CA-TR	
SMAJ43CA-TR	SMAJ43CA-TR	
SMAJ48CA-TR	SMAJ48CA-TR	
SMAJ58CA-TR	SMAJ58CA-TR	
SMAJ70CA-TR	SMAJ70CA-TR	

SMBJ12A-TR	SMBJ12A-TR	
SMBJ12CA-TR	SMBJ12CA-TR	
SMBJ13CA-TR	SMBJ13CA-TR	
SMBJ15A-TR	SMBJ15A-TR	
SMBJ15CA-TR	SMBJ15CA-TR	
SMBJ16A-TR	SMBJ16A-TR	
SMBJ18A-TR	SMBJ18A-TR	
SMBJ18CA-TR	SMBJ18CA-TR	
	SMBJ20A-TR	
SMBJ20CA-TR	SMBJ20CA-TR	
SMBJ22A-TR	SMBJ22A-TR	
	SMBJ22CA-TR	
SMBJ24A-TR	SMBJ24A-TR	
SMBJ24CA-TR	SMBJ24CA-TR	
SMBJ26A-TR	SMBJ26A-TR	
	SMBJ26CA-TR	
SMBJ28A-TR	SMBJ28A-TR	
	SMBJ28CA-TR	
SMBJ30A-TR	SMBJ30A-TR	
SMBJ30CA-TR	SMBJ30CA-TR	
SMBJ33A-TR	SMBJ33A-TR	
SMBJ33CA-TR	SMBJ33CA-TR	
SMBJ36CA-TR	SMBJ36CA-TR	
SMBJ40CA-TR	SMBJ40CA-TR	
SMBJ48CA-TR	SMBJ48CA-TR	
SMBJ58CA-TR	SMBJ58CA-TR	
SMBJ70CA-TR	SMBJ70CA-TR	

IMPORTANT NOTICE – PLEASE READ CAREFULLY

Subject to any contractual arrangement in force with you or to any industry standard implemented by us, STMicroelectronics NV and its subsidiaries (“ST”) reserve the right to make changes, corrections, enhancements, modifications, and improvements to ST products and/or to this document at any time without notice. Purchasers should obtain the latest relevant information on ST products before placing orders. ST products are sold pursuant to ST’s terms and conditions of sale in place at the time of order acknowledgement.

Purchasers are solely responsible for the choice, selection, and use of ST products and ST assumes no liability for application assistance or the design of Purchasers’ products.

No license, express or implied, to any intellectual property right is granted by ST herein.

Resale of ST products with provisions different from the information set forth herein shall void any warranty granted by ST for such product.

ST and the ST logo are trademarks of ST. All other product or service names are the property of their respective owners.

Information in this document supersedes and replaces information previously supplied in any prior versions of this document.

© 2022 STMicroelectronics – All rights reserved

Qualification Report

Plant transfer for TVS (SMA and SMB packages)

General Information		Locations	
Product Line	Protection	Wafer Fab	ST Tours (France)
Product Description	Industrial TVS products SMA and SMB packages	Assembly Plant	Subcontractor (990C) - China
Product Perimeter	SMAJxxx SM6Txxx SMBJxxx	Reliability Lab	ST Tours (France)
Product Group	APMS		
Product Division	Discrete & Filter		
Packages	SMA - SMB		
Maturity level step	Qualified	Reliability Assessment	Compliant

DOCUMENT INFORMATION

Version	Date	Pages	Prepared by	Approved by	Comments
1.0	April 12, 2024	20	A. KHEDIM	Timothée PINGAULT <small>Digitally signed by Timothée PINGAULT Date: 2024.04.12 14:27:06 +02'00'</small>	Document creation

Note: This report is a summary of the qualification trials performed in good faith by STMicroelectronics in order to evaluate the potential risks during the product life using a set of defined test methods. This report does not imply for STMicroelectronics expressly or implicitly any contractual obligations other than as set forth in STMicroelectronics general terms and conditions of Sale. This report and its contents shall not be disclosed to a third party without previous written agreement from STMicroelectronics.

TABLE OF CONTENTS

1	APPLICABLE AND REFERENCE DOCUMENTS	3
2	GLOSSARY	3
3	RELIABILITY EVALUATION OVERVIEW	4
3.1	OBJECTIVES	4
3.2	CONCLUSION	5
4	DEVICE CHARACTERISTICS	6
4.1	DEVICE DESCRIPTION	6
4.2	CONSTRUCTION NOTE	8
5	TESTS PLAN AND RESULTS SUMMARY	9
5.1	TEST VEHICLES	9
5.2	TEST PLAN	10
5.3	RESULTS SUMMARY	13
6	ANNEXES	15
6.1	PARAMETRIC VERIFICATION	15
6.2	PHYSICAL DIMENSIONS	15
6.3	TESTS DESCRIPTION	19

1 APPLICABLE AND REFERENCE DOCUMENTS

Document reference	Short description
JESD 47	Stress-Test-Driven Qualification of Integrated Circuits
JESD 94	Application specific qualification using knowledge based test methodology
JESD 22	Reliability test methods for packaged devices
MIL-STD-750C	Test method for semiconductor devices

2 GLOSSARY

DBT	Dead bug test
DPA	Destructive Physical Analysis
GD	Generic Data
H3TRB	High Humidity High Temperature Reverse Bias
HTRB	High Temperature Reverse Bias
PD	Physical Dimensions
PV	Parametric Verification
RS	Repetitive Surges
RSH	Resistance to solder heat
SD	Solderability
SS	Sample Size
TC	Temperature Cycling
UHAST	Unbiased Highly Accelerated Stress Test

3 RELIABILITY EVALUATION OVERVIEW

3.1 Objectives

Due to plant rationalization at subcontractor level, STMicroelectronics has qualified a new plant to support TVS products business continuity.

The objective is to qualify the plant transfer (same subcontractor, no change in BOM, lead frame, plating, resin nor tools) of SMA and SMB lines.

The impacted products are the following:

- 400W & 600W TVS embedded in SMA package,
- 600W TVS embedded in SMB package.

Commercial Product	Package	Comment (optional)
SMAJxxx SM6Txxx SMBJxxx	SMA SMA SMB	Industrial grade

Impacted products		
SMAJ12A	SM6T15A	SMBJ12A
SMAJ12CA	SM6T15CA	SMBJ12CA
SMAJ13A	SM6T18A	SMBJ13CA
SMAJ13CA	SM6T18CA	SMBJ15A
SMAJ15A	SM6T22A	SMBJ15CA
SMAJ15CA	SM6T22CA	SMBJ16A
SMAJ18A	SM6T24A	SMBJ18A
SMAJ18CA	SM6T24CA	SMBJ18CA
SMAJ20A	SM6T27A	SMBJ20A
SMAJ24A	SM6T27CA	SMBJ20CA
SMAJ24CA	SM6T30A	SMBJ22ATR
SMAJ26A	SM6T30CA	SMBJ22CA
SMAJ26CA	SM6T33A	SMBJ24A
SMAJ28A	SM6T33CA	SMBJ24CA
SMAJ28CA	SM6T36A	SMBJ26A
SMAJ30A	SM6T36CA	SMBJ26CA
SMAJ30CA	SM6T39A	SMBJ28A
SMAJ33A	SM6T39CA	SMBJ28CA
SMAJ33CA	SM6T56CA	SMBJ30A
SMAJ40CA	SM6T68CA	SMBJ30CA
SMAJ43CA		SMBJ33A
SMAJ48CA		SMBJ33CA
SMAJ58CA		SMBJ36CA
SMAJ70CA		SMBJ40CA
		SMBJ48CA
		SMBJ58CA
		SMBJ70CA

The reliability test methodology used follows the JESD47: "Stress Test driven Qualification Methodology".

The reliability tests ensuing are:

- TC to ensure the mechanical robustness of the products.
- HTRB to evaluate the risk of contamination from the resin and the assembly process versus the die layout sensitivity.
- H3TRB, UHAST to check the robustness to corrosion and the good package hermeticity.
- RSH, Solderability and DBT to check compatibility of package with customer assembly.
- Functional test: Repetitive IPP to verify robustness of device submitted to rated Ipp (as per data sheet)

For some tests, similarity methodology is used. See 5.1 "comments" for more details about similarities.

3.2 Conclusion

Qualification Plan requirements have been fulfilled without exception. Reliability tests have shown that the devices behave correctly against environmental tests (no failure). Moreover, the stability of electrical parameters during the accelerated tests demonstrates the robustness of the products and safe operation, which is consequently expected during their lifetime.

Based on these results, TVS in SMD packages are compliant with JESD47.

4 DEVICE CHARACTERISTICS

4.1 Device description

Example datasheet of TVS SMA package (SMAJ70CA)



SMAJxxA, SMAJxxCA

Datasheet

400 W TVS in SMA

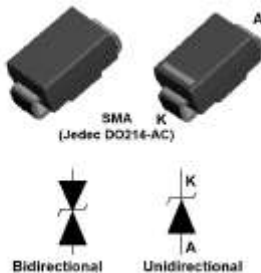

Features

- Peak pulse power:
 - 400 W (10/1000 μ s)
 - 2.3 kW (8/20 μ s)
- Stand-off voltage range from 5 V to 188 V
- Unidirectional and bidirectional types
- Low leakage current:
 - 0.2 μ A at 25 °C
 - 1 μ A at 85 °C
- Operating T_J max: 150 °C
- JEDEC registered package outline

Complies with the following standards

- UL94, V0
- J-STD-020 MSL level 1
- J-STD-002, JESD 22-B102 E3 and MIL-STD-750, method 2028 solderable matte tin plated leads
- JESD-201 class 2 whisker test
- IPC7531 footprint
- JEDEC registered package outline
- IEC 61000-4-4 level 4:
 - 4 kV
- IEC 61000-4-2, C = 150 pF - R = 330 Ω exceeds level 4:
 - 30 kV (air discharge)
 - 30 kV (contact discharge)

Description

The SMAJ series is designed to protect sensitive equipment against electrostatic discharges according to IEC 61000-4-2 and MIL STD 883, method 3015, and electrical overstress according to IEC 61000-4-4 and 5. This device is more generally used against surges below 600 W (10/1000 μ s).

The Planar technology makes it compatible with high-end circuits where low leakage current and high junction temperature are required to provide long term reliability and stability. SMAJ devices are packaged in SMA (SMA footprint in accordance with IPC 7531 standard).

Product status links

[SMAJ5.0A, SMAJ5.0CA,](#)
[SMAJ6.0A, SMAJ6.0CA,](#)
[SMAJ6.5A, SMAJ6.5CA,](#)
[SMAJ8.5A, SMAJ8.5CA,](#)
[SMAJ10A, SMAJ10CA,](#)
[SMAJ12A, SMAJ12CA,](#)
[SMAJ13A, SMAJ13CA,](#)
[SMAJ15A, SMAJ15CA,](#)
[SMAJ18A, SMAJ18CA,](#)
[SMAJ20A, SMAJ20CA,](#)
[SMAJ24A, SMAJ24CA,](#)
[SMAJ26A, SMAJ26CA,](#)
[SMAJ28A, SMAJ28CA,](#)
[SMAJ30A, SMAJ30CA,](#)
[SMAJ33A, SMAJ33CA,](#)
[SMAJ40A, SMAJ40CA,](#)
[SMAJ43A, SMAJ43CA,](#)
[SMAJ48A, SMAJ48CA,](#)
[SMAJ58A, SMAJ58CA,](#)
[SMAJ70A, SMAJ70CA,](#)
[SMAJ85A, SMAJ85CA,](#)
[SMAJ100A, SMAJ100CA,](#)
[SMAJ130A, SMAJ130CA,](#)
[SMAJ154A, SMAJ154CA,](#)
[SMAJ170A, SMAJ170CA,](#)
[SMAJ188A, SMAJ188CA.](#)

Example datasheet of TVS SMB package (SMBJ33A)



SMBJ

Datasheet

600 W TVS in SMB

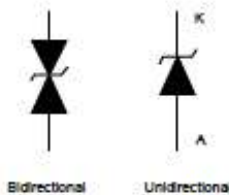

Features

- Peak pulse power: 600 W (10/1000 μ s) and 4 kW (8/20 μ s)
- Stand-off voltage range from 5 V to 188 V
- Unidirectional and bidirectional types
- Low leakage current: 0.2 μ A at 25 °C and 1 μ A at 85 °C
- Operating T_j max: 150 °C
- High power capability at T_j max.: up to 515 W (10/1000 μ s)
- Lead finishing: matte tin plating

Complies with the following standards

- UL94, V0
- J-STD-020 MSL level 1
- J-STD-002, JESD 22-B102 E3 and MIL-STD-750, method 2026 solderable matte tin plated leads
- JESD-201 class 2 whisker test
- IPC7531 footprint
- JEDEC registered package outline
- IEC 61000-4-4 level 4:
 - 4 kV
- IEC 61000-4-2, C = 150 pF - R = 330 Ω exceeds level 4:
 - 30 kV (air discharge)
 - 30 kV (contact discharge)

Description

The SMBJ series are designed to protect sensitive equipment against electrostatic discharges according to IEC 61000-4-2 and MIL STD 883, method 3015, and electrical overstress according to IEC 61000-4-4 and 5. This device is more generally used against surges below 600 W (10/1000 μ s).

The Planar technology makes it suitable for high-end equipment and SMPS where low leakage current and high junction temperature are required to provide reliability and stability over time.

The SMBJ series are packaged in SMB.

Product status link	
SMBJ	SMBJ5.0A, SMBJ5.0CA, SMBJ6.0A, SMBJ6.0CA, SMBJ6.5A, SMBJ6.5CA, SMBJ8.5A, SMBJ8.5CA, SMBJ10A, SMBJ10CA, SMBJ12A, SMBJ12CA, SMBJ13A, SMBJ13CA, SMBJ15A, SMBJ15CA, SMBJ16A, SMBJ16CA, SMBJ18A, SMBJ18CA, SMBJ20A, SMBJ20CA, SMBJ22A, SMBJ22CA, SMBJ24A, SMBJ24CA, SMBJ26A, SMBJ26CA, SMBJ28A, SMBJ28CA, SMBJ30A, SMBJ30CA, SMBJ33A, SMBJ33CA, SMBJ36A, SMBJ36CA, SMBJ40A, SMBJ40CA, SMBJ43A, SMBJ43CA, SMBJ48A, SMBJ48CA, SMBJ58A, SMBJ58CA, SMBJ64A, SMBJ64CA, SMBJ70A, SMBJ70CA, SMBJ85A, SMBJ85CA, SMBJ100A, SMBJ100CA, SMBJ130A, SMBJ130CA, SMBJ154A, SMBJ154CA, SMBJ170A, SMBJ170CA, SMBJ188A, SMBJ188CA

4.2 Construction Note

400W, 600W TVS package SMA qualification	
Wafer/Die fab. information	
Wafer fab manufacturing location	ST Tours - France
Technology / Process family	Discrete Transil
Wafer Testing (EWS) information	
Electrical testing manufacturing location	ST Tours - France
Assembly information	
Assembly site	Subcontractor (990C) - China
Package description	SMA
Molding compound	ECOPACK@2 molding compound
Lead finishing material	Lead free (pure Tin)
Final testing information	
Testing location	Subcontractor (990C) - China

600W TVS SMB qualification	
Wafer/Die fab. information	
Wafer fab manufacturing location	ST Tours - France
Technology / Process family	Discrete Transil
Wafer Testing (EWS) information	
Electrical testing manufacturing location	ST Tours - France
Assembly information	
Assembly site	Subcontractor (990C) - China
Package description	SMB
Molding compound	ECOPACK@2 molding compound
Lead finishing material	Lead free (pure Tin)
Final testing information	
Testing location	Subcontractor (990C) - China

5 TESTS PLAN AND RESULTS SUMMARY

5.1 Test vehicles

Lot #	Finish Good	Package	Comments
Lot 1	SMAJ70CA	SMA	Qualification lot
Lot 2	SMBJ33A	SMB	Qualification lot
Lot 3	SMBJ33A	SMB	Qualification lot
Lot 4	SMBJ70CA	SMB	Qualification lot
Lot 5	SMBJ70CA	SMB	Qualification lot
Lot 6	SMAJ33A	SMA	Qualification lot
Lot 7	SMAJ70CA	SMA	Qualification lot
Lot 8	SMBJ33A	SMB	Qualification lot

Detailed results in the chapter below will refer to these references.

5.2 **Test plan**

Stress	Abrv	Reference	Lot	SS	Comments	Test plan
Pre and Post-Stress Electrical Test	TEST	User specification or supplier's standard Specification	All qualification parts tested per the requirements of the appropriate device specification.			
Pre-conditioning	PC	J-STD-020 JESD22-A113	All qualification parts tested per the requirements of the appropriate device specification.		As per targeted MSL Not applicable for PTH and WLCSP without coating	
MSL research	MSL	J-STD-020			Not applicable for PTH and WLCSP without coating	
External Visual	EV	JESD22B-101	All qualification parts tested per the requirements of the appropriate device specification.		Done during Assembly → Test & Finish inspection	
Parametric Verification	PV	User specification				
High Temperature Reverse Bias	HTRB	MIL-STD-750-1 M1038 Method A (for diodes, rectifiers and Zeners) M1039 Method A (for transistors)	Lot 1 Lot 2 Lot 3 Lot 4 Lot 5 Lot 6 Lot 7 Lot 8	45 45 45 45 45 45 45 45		X
AC blocking voltage	ACBV	MIL-STD-750-1 M1040 Test condition A			Required for Thyristor only. Alternative to HTRB	
High Temperature Forward Bias	HTFB	JESD22 A-108			Not required, applicable only to LEDS Alternative to HTRB	
High Temperature Operating Life	HTOL				Covered by HTRB or ACBV	
Steady State Operational	SSOP	MIL-STD-750-1 M1038 Test condition B			Required for Voltage Regulator (Zener) only.	
High Temperature Gate Bias	HTGB	JESD 22A-108			Required for Power MOSFET – IGBT only.	
High Temperature Storage Life	HTSL	JESD22 A-103			Covered by H3TRB	
Temperature Humidity Storage	THS	JESD22 A-118			Covered by H3TRB	
Temperature Cycling	TC	JESD22A-104	Lot 1 Lot 2 Lot 3 Lot 4 Lot 5 Lot 6 Lot 7 Lot 8	30 30 30 30 30 25 25 25		X
Temperature Cycling Hot Test	TCHT	JESD22A-104			Required for Power MOSFET – IGBT only.	
Temperature Cycling Delamination Test	TCDT	JESD22A-104 J-STD-035			Required for Power MOSFET – IGBT only. Alternative to TCHT	
Wire Bond Integrity	WBI	MIL-STD-750 Method 2037			For dissimilar metal bonding systems only	
Unbiased Highly Accelerated Stress Test	UHASt	JESD22A-118 or A101	Lot 1 Lot 2 Lot 3	77 77 77		X

Stress	Abrv	Reference	Lot	SS	Comments	Test plan
			Lot 4 Lot 5 Lot 6 Lot 7 Lot 8	77 77 25 25 25		
Autoclave	AC	JESD22A-102			Alternative to UHAST	
Highly Accelerated Stress Test	HAST	JESD22A-110			Covered by H3TRB (same failure mechanisms activation).	
High Humidity High Temperature Reverse Bias	H3TRB	JESD22A-101	Lot 1 Lot 2 Lot 3 Lot 4 Lot 5 Lot 6 Lot 7 Lot 8	25 25 25 25 25 25 25 25	Alternative to HAST	X
High Temperature High Humidity Bias	HTHH B	JED22A-101			Not required, LED only	
Intermittent Operational Life / Thermal Fatigue	IOL	MIL-STD-750 Method 1037			For power devices. Not required for Transient Voltage Suppressor (TVS) parts	
Power and Temperature Cycle	PTC	JED22A-105			For power devices. Not required for Transient Voltage Suppressor (TVS) parts Perform PTC if $\Delta T_j > 100^\circ\text{C}$ cannot be achieved with IOL Alternative to IOL	
ESD Characterization	ESD HBM	AEC Q101-001 and 005				
ESD Characterization	ESD CDM	AEC Q101-001 and 005				
Destructive Physical Analysis	DPA	AEC-Q101-004 Section 4			After H3TRB and TC	X
Physical Dimension	PD	JESD22B-100				
Terminal Strength	TS	MIL-STD-750 Method 2036			Required for leaded parts only	
Resistance to Solvents	RTS	JESD22B-107			Not applicable for Laser Marking	
Constant Acceleration	CA	MIL-STD-750 Method 2006			Required for hermetic packaged parts only.	
Vibration Variable Frequency	VVF	JESD22B-103			Required for hermetic packaged parts only.	
Mechanical Shock	MS	JESD22 B-104			Required for hermetic packaged parts only.	
Hermeticity	HER	JESD22A-109			Required for hermetic packaged parts only.	
Resistance to Solder Heat	RSH	JESD22 A-111 (SMD)	Lot 1 Lot 4 Lot 6 Lot 7	30 30 30		X
Solderability	SD	J-STD-002 JESD22B102	Lot 5	4*15		X
Dead Bug Test	DBT	ST Internal specification	Lot 1 Lot 4	2*30 2*30		X
Thermal Resistance	TR	JESD24-3, 24-4, 24-6 as appropriate			Required in case of process change. Not applicable to protection device as no limit specified in the datasheet	



Stress	Abrv	Reference	Lot	SS	Comments	Test plan
Wire Bond Strength	WBS	MIL-STD-750 Method 2037			Covered during workability trials	
Bond Shear	BS	AEC-Q101-003			Covered during workability trials	
Die Shear	DS	MIL-STD-750 Method 2017			Not Applicable to parts with solder paste die attach	
Unclamped Inductive Switching	UIS	AEC-Q101-004 section 2			Required for Power MOS and internally clamped IGBTs only	
Dielectric Integrity	DI	AEC-Q101-004 section 3			Required for Power MOSFET – IGBT only.	
Short Circuit Reliability Characterization	SCR	AEC-Q101-006			Required for smart power parts only	
Whisker Growth Evaluation	WG	AEC-Q005 JESD201				
Early Life Failure Rate	ELFR	JESD74			Recommended for new techno development in case of identified failure mechanism	
Functional Test (in rush, di/dt,...)	FT	Internal specification				
Repetitive Surge	RS	Internal specification	Lot 1 Lot 2 Lot 3 Lot 4 Lot 5 Lot 6 Lot 7 Lot 8	20 20 20 20 20 20 20 20	Required for protection devices only.	X

Low Temperature Storage	LTS	JESD-22 A119: 209			AQG324 test for Modules	
Thermal shock test	TST	JESD22-A104			AQG324 test for Modules	
Power Cycling (seconds)	PCsec	MIL-STD750-1 Method1037			AQG324 test for Modules	
Power Cycling (minutes)	PCmin	MIL-STD750-1 Method1037			AQG324 test for Modules	
Mechanical shock	MS	IEC 600068-2-27			AQG324 test for Modules	
Vibration	V	IEC60068-2-6			AQG324 test for Modules	

5.3 Results summary

Test	PC	Std ref.	Conditions	Total	Steps	Results / Lot								
						Fail/s.s.								
						SMAJ70CA	SMBJ33A	SMBJ70CA	SMBJ70CA	SMAJ33A	SMAJ70CA	SMBJ33A	SMAJ70CA	SMBJ33A
						Lot 1	Lot 2	Lot 3	Lot 4	Lot 5	Lot 6	Lot 7	Lot 8	Lot 8
Pre-and Post Electrical Test	-	ST datasheet	IR, VBR, VF parameters according to product datasheet	1530	-									
External Visual	-	JESD22B-101	All qualification parts submitted for testing passed External & Visual inspection during manufacturing process											0/1530
Parametric Verification	-	ST datasheet	Over part temperature range (note1)											
			Junction											
HTRB	N	MIL-STD-750-1 M1038 Method A	Temperature=150°C Temperature=150°C Tension=V _{rm}	315	1000h	0/45	0/45	0/45	0/45	0/45	0/45	0/45	0/45	0/45
TC	Y	JESD22-A104	Frequency (cy/h)=2cy/h Temperature (high)=150°C Temperature (low)=-65°C	300	500cy	0/45	0/45	0/45	0/45	0/45	0/25	0/25	0/25	0/25
RSH	N	JESD22A-111 (SMD) / JESD22B-106 (PTH)	Temperature=260°C Time (on)=10s	120	Measure after dipping	0/30			0/30		0/30		0/30	
H3TRB	Y	JESD22-A101	Humidity (HR)=85% Temperature=85°C Tension= V _{rm} (max 100V)	175	1000h	0/25	0/25	0/25	0/25	0/25	0/25	0/25	0/25	0/25
UHAST	Y	JESD22 A-118	Humidity (HR)=85% Pressure=2.3bar Temperature=130°C	460	96h	0/77	0/77	0/77	0/77	0/77	0/25	0/25	0/25	0/25
Solderability	N	J-STD-002 (test B SMD)	Wet aging = 8h Metal (solder) = SnPb No data dream = 1 No elec Measurement=1 Temperature=220°C	15	Visual inspection					0/15				



Test	PC	Std ref.	Conditions	Total	Steps	Results / Lot								
						SMA/70CA Lot 1	SMB/33A Lot 2	SMB/33A Lot 3	SMB/70CA Lot 4	SMB/70CA Lot 5	SMA/33A Lot 6	SMA/70CA Lot 7	SMB/33A Lot 8	
Solderability	N	J-STD-002 (test B SMD)	Dry aging = 16h Metal (solder) = SnAgCu No data dream = 1 No elec Measurement=1 Temperature=245°C	15	Visual inspection					0/15				
Solderability	N	J-STD-002 (test B SMD)	Wet aging = 8h Metal (solder) = SnAgCu No data dream = 1 No elec Measurement=1 Temperature=245°C	15	Visual inspection					0/15				
Solderability	N	J-STD-002 (test B SMD)	Dry aging = 16h Metal (solder) = SnPb No data dream = 1 No elec Measurement=1 Temperature=220°C	15	Visual inspection					0/15				
DBT	N	DM00112629	No Data Dream=1 No Elec Measurement=1 Reflow=1	60	Visual inspection	0/30				0/30				
DBT	N	DM00112629	No Data Dream=1 No Elec Measurement=1 Reflow=1	60	Visual inspection	0/30				0/30				
Functional test														
Repetitive Surge	Y	ADCS0060282	IPP=IPP datasheet Pulse delay=0.01ms Time between surge=60s	160	50 surges	0/20	0/20	0/20	0/20	0/20	0/20	0/20	0/20	0/20

Note 1: These data are indicative values given as information only. Please note that the ST guarantee is the compliance of the products to the ST datasheet. Parameters distributions are not considered as a ST guarantee under any circumstances.
Please note that these electrical parameters are 100% tested at 25°C at Final stage of back-end manufacturing before deliveries to customers.”

6 ANNEXES

6.1 Parametric Verification

SMAJ33A

Characterization SMAJ33A							
Date : 05/04/2024							
Ref : 23515A							
Lab : ST Tours Characterization Lab							
TEST	VBR	IRM	IRM	VCL 10/1000 μ s	RD	VCL 8/20 μ s	RD
EQUIPMENT	TESEC	TESEC	TESEC	TESEC	TEST CALCULES	TESEC	TESTS_CALCULES
Condition 1	25°C	25°C	85°C	25°C	25°C	25°C	25°C
Condition 2	IR=1mA	VRM=33V	VRM=33V	IPP=7.5A	IF1=3.75A	IPP=33A	IF1=16.5A
Condition 3					IF2=7.5A		IF2=33A
Condition 4					VR1= 1-VCL 10/1000 μ s		VR1= 1-VCL 8/20 μ s
Condition 5					VR2= 2-VCL 10/1000 μ s		VR2= 2-VCL 8/20 μ s
Min. Datasheet	36.7						
Typ. Datasheet	38.6						
Max. Datasheet		0.2 μ A	1 μ A	53.3	1.70	69.7	0.884ohm
Comments	Direct	Direct	Direct	Direct	Direct	Direct	Direct
UNIT	V	nA	nA	V	Ohm	V	Ohm
N	30	30	30	30	30	30	30
Min	37.83	1.27	3.34	45.9	0.96	48.69	0.324
Max	39.13	10.23	47.13	48.3	1.2	52.71	0.379
Avg.	38.49	4.48	20.11	46.8	1.04	50.5	0.341
(*)These data are indicative values given as information only. Please note that the ST guarantee is the compliance of the products to the ST datasheet. Parameters distributions are not considered as a ST guarantee under any circumstances. Please note that these electrical parameters are 100% tested at 25°C at Final stage of back-end manufacturing before deliveries to customers							

SMBJ33A

Characterization SMBJ33A							
Date : 05/04/2024							
Ref : 23534A							
Lab : ST Tours Characterization Lab							
TEST	VBR	IRM	IRM	VCL 10/1000 μ s	RD	VCL 8/20 μ s	RD
EQUIPMENT	TESEC	TESEC	TESEC	TESEC	TEST CALCULES	TESEC	TESTS_CALCULES
Condition 1	25°C	25°C	85°C	25°C	25°C	25°C	25°C
Condition 2	IR=1mA	VRM=33V	VRM=33V	IPP=11.8A	IF1=5.9A	IPP=57A	IF1=28.5A
Condition 3					IF2=11.8A		IF2=57A
Condition 4					VR1= 1-VCL 10/1000 μ s		VR1= 1-VCL 8/20 μ s
Condition 5					VR2= 2-VCL 10/1000 μ s		VR2= 2-VCL 8/20 μ s
Min. Datasheet	36.7						
Typ. Datasheet	38.6						
Max. Datasheet		0.2 μ A	1 μ A	53.3	1.08	69.7	0.512ohm
Comments	Direct	Direct	Direct	Direct	Direct	Direct	Direct
UNIT	V	nA	nA	V	Ohm	V	Ohm
N	30	30	30	30	30	30	30
Min	38.41	1.975	6.975	46.2	0.576	51.32	0.191
Max	40	7.863	11.93	48.3	0.83	54.08	0.225
Avg.	38.99	2.719	9.62	46.96	0.663	52.49	0.212
(*)These data are indicative values given as information only. Please note that the ST guarantee is the compliance of the products to the ST datasheet. Parameters distributions are not considered as a ST guarantee under any circumstances. Please note that these electrical parameters are 100% tested at 25°C at Final stage of back-end manufacturing before deliveries to customers							

SMBJ70CA

Characterization SMBJ70CA								
Date : 05/04/2024								
Ref : 23516A								
Lab : ST Tours Characterization Lab								
TEST	VBR	VBR	IRM	IRM	IRM	IRM		
EQUIPMENT	TESEC	TESEC	TESEC	TESEC	TESEC	TESEC		
Condition 1	25°C	25°C	25°C	25°C	85°C	85°C		
Condition 2	IR=1mA	IR=1mA	VRM=70V	VRM=70V	VRM=70V	VRM=70V		
Condition 3								
Condition 4								
Condition 5								
Min. Datasheet	77.8	77.8						
Typ. Datasheet	81.9	81.9						
Max. Datasheet			0,2µA	0,2µA	1µA	1µA		
Comments	Direct	Reverse	Direct	Reverse	Direct	Reverse		
UNIT	V	V	nA	nA	nA	nA		
N	30	30	30	30	30	30		
Min	79.98	80.12	1.074	0.952	4.42	2.393		
Max	83.17	82.25	26.86	27.91	46.83	40.78		
Avg.	81.37	81.15	6.687	9.846	19.109	20.215		
TEST	VCL 10/1000 µs	VCL 10/1000 µs	RD	RD	VCL 8/20 µs	VCL 8/20 µs	RD	RD
EQUIPMENT	TESEC	TESEC	TEST CALCULES	TEST CALCULES	TESEC	TESEC	TESTS_CALCULES	TESTS_CALCULES
Condition 1	25°C	25°C	25°C	25°C	25°C	25°C	25°C	25°C
Condition 2	IPP=5,5A	IPP=5,5A	IF1=2,75A	IF1=2,75A	IPP=27A	IPP=27A	IF1=13,5A	IF1=13,5A
Condition 3			IF2=5,5A	IF2=5,5A			IF2=27A	IF2=27A
Condition 4			VR1= 1-VCL 10/1000 µs	VR1= 1-VCL 10/1000 µs			VR1= 1-VCL 8/20 µs	VR1= 1-VCL 8/20 µs
Condition 5			VR2= 2-VCL 10/1000 µs	VR2= 2-VCL 10/1000 µs			VR2= 2-VCL 8/20 µs	VR2= 2-VCL 8/20 µs
Min. Datasheet								
Typ. Datasheet								
Max. Datasheet	113	113	4.91	4.91	146	146	2,2ohm	2,2ohm
Comments	Direct	Reverse	Direct	Reverse	Direct	Reverse	Direct	Reverse
UNIT	V	V	Ohm	Ohm	V	V	ohm	ohm
N	15	15	15	15	15	15	15	15
Min	95	94.9	2.109	2.472	98.08	98.08	0.611	0.603
Max	97.5	97.1	3.381	2.909	100.83	100.83	0.679	0.679
Avg.	96.04	95.9	2.766	2.71	99.48	99.48	0.642	0.6373
(**)These data are indicative values given as information only. Please note that the ST guarantee is the compliance of the products to the ST datasheet. Parameters distributions are not considered as a ST guarantee under any circumstances.								
Please note that these electrical parameters are 100% tested at 25°C at Final stage of back-end manufacturing before deliveries to customers								

6.2 Physical Dimensions

SMA package dimensions

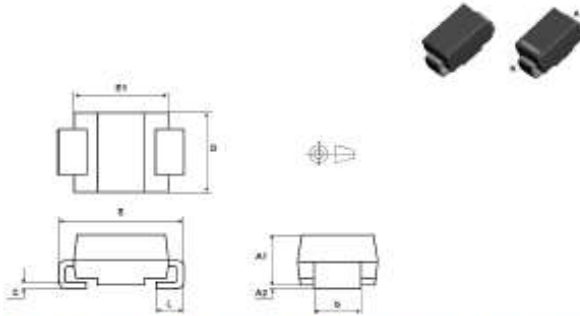

Ref.	Millimeters	
	Min.	Max.
A1	1.90	2.45
A2	0.05	0.20
b	1.25	1.65
c	0.15	0.40
D	2.25	2.90
E	4.80	5.35
E1	3.95	4.60
L	0.75	1.50

Spec	A1	A2	b	c	D	E	E1	L
MIN:	1.90	0.05	1.25	0.15	2.25	4.80	3.95	0.75
MAX:	2.45	0.20	1.65	0.40	2.90	5.35	4.60	1.50
1	2.134	0.142	1.549	0.280	2.818	5.069	4.380	1.066
2	2.107	0.150	1.536	0.250	2.825	5.065	4.379	1.055
3	2.138	0.133	1.539	0.268	2.800	5.080	4.383	1.040
4	2.129	0.113	1.551	0.277	2.806	5.128	4.371	1.037
5	2.124	0.124	1.537	0.271	2.810	5.115	4.364	1.051
6	2.093	0.137	1.528	0.261	2.817	5.062	4.371	1.055
7	2.116	0.144	1.551	0.275	2.802	5.117	4.375	1.039
8	2.087	0.104	1.539	0.266	2.810	5.131	4.379	1.023
9	2.132	0.118	1.543	0.273	2.804	5.080	4.382	1.041
10	2.132	0.122	1.541	0.280	2.814	5.133	4.375	1.021
11	2.137	0.142	1.535	0.271	2.801	5.088	4.379	1.021
12	2.089	0.132	1.528	0.261	2.806	5.109	4.371	1.016
13	2.146	0.137	1.533	0.267	2.820	5.123	4.380	1.072
14	2.136	0.112	1.544	0.270	2.818	5.096	4.366	1.045
15	2.115	0.132	1.533	0.271	2.813	5.092	4.368	1.042
16	2.107	0.119	1.532	0.276	2.837	5.097	4.382	1.039
17	2.125	0.130	1.541	0.269	2.819	5.104	4.375	1.020
18	2.132	0.134	1.532	0.265	2.803	5.112	4.376	1.045
19	2.139	0.142	1.528	0.268	2.827	5.113	4.379	1.029
20	2.121	0.118	1.529	0.263	2.804	5.127	4.383	1.016
21	2.130	0.140	1.543	0.271	2.823	5.127	4.368	1.040
22	2.146	0.136	1.555	0.273	2.814	5.079	4.362	1.020
23	2.114	0.130	1.536	0.263	2.799	5.102	4.376	1.036
24	2.126	0.140	1.549	0.272	2.820	5.133	4.380	1.037
25	2.133	0.137	1.537	0.272	2.820	5.088	4.375	1.052
26	2.099	0.116	1.530	0.268	2.809	5.177	4.389	1.030
27	2.089	0.107	1.524	0.266	2.820	5.075	4.383	1.063
28	2.108	0.111	1.547	0.274	2.825	5.079	4.376	1.074
29	2.100	0.105	1.531	0.274	2.814	5.110	4.370	1.058
30	2.140	0.134	1.540	0.268	2.816	5.110	4.385	1.042
MIN	2.087	0.104	1.524	0.250	2.799	5.062	4.362	1.016
MAX	2.146	0.150	1.555	0.280	2.837	5.177	4.389	1.074
AVG	2.121	0.128	1.538	0.269	2.814	5.104	4.376	1.041

SMB package dimensions

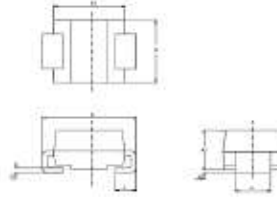
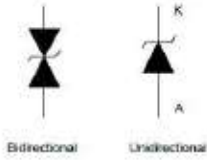

Ref	Dimension			
	Millimeters		Inches ⁽¹⁾	
	Min.	Max.	Min.	Max.
A1	1.90	2.45	0.0748	0.0969
A2	0.05	0.30	0.0020	0.0118
b	1.95	2.20	0.0768	0.0867
c	0.15	0.40	0.0059	0.0157
D	3.30	3.95	0.1299	0.1556
E	5.10	5.60	0.2008	0.2205
E1	4.05	4.30	0.1594	0.1693
L	0.75	1.50	0.0295	0.0591

Cote	A1	A2	b	c	D	E	E1	L
1	2.18	0.16	2.04	0.28	3.52	5.34	4.55	1.09
2	2.14	0.17	2.03	0.29	3.51	5.38	4.51	1.11
3	2.18	0.17	2.03	0.28	3.51	5.35	4.55	1.08
4	2.17	0.16	2.01	0.29	3.52	5.38	4.53	1.10
5	2.11	0.16	2.03	0.29	3.51	5.35	4.51	1.12
6	2.14	0.14	2.02	0.29	3.53	5.34	4.55	1.10
7	2.16	0.15	2.02	0.28	3.47	5.33	4.51	1.09
8	2.17	0.16	2.02	0.28	3.50	5.35	4.53	1.06
9	2.17	0.16	2.02	0.27	3.51	5.36	4.51	1.09
10	2.17	0.15	2.01	0.28	3.49	5.34	4.51	1.11
11	2.17	0.16	2.03	0.28	3.50	5.36	4.52	1.07
12	2.17	0.16	2.03	0.28	3.51	5.37	4.54	1.07
13	2.16	0.15	2.04	0.28	3.52	5.36	4.51	1.08
14	2.18	0.16	2.02	0.29	3.51	5.39	4.54	1.07
15	2.17	0.14	2.02	0.28	3.50	5.38	4.53	1.09
16	2.17	0.16	2.02	0.29	3.53	5.36	4.52	1.10
17	2.17	0.16	2.05	0.27	3.52	5.38	4.51	1.10
18	2.18	0.15	2.03	0.28	3.53	5.37	4.50	1.11
19	2.15	0.15	2.02	0.27	3.50	5.37	4.52	1.11
20	2.17	0.16	2.02	0.28	3.53	5.37	4.53	1.11
21	2.16	0.16	2.01	0.28	3.56	5.34	4.50	1.10
22	2.17	0.16	2.03	0.28	3.56	5.41	4.52	1.07
23	2.16	0.15	2.02	0.28	3.55	5.37	4.50	1.11
24	2.18	0.16	2.03	0.29	3.52	5.33	4.53	1.11
25	2.17	0.14	2.03	0.29	3.55	5.35	4.52	1.11
26	2.17	0.15	2.02	0.28	3.50	5.37	4.52	1.09
27	2.18	0.15	2.02	0.29	3.55	5.36	4.51	1.08
28	2.17	0.16	2.02	0.28	3.56	5.34	4.51	1.09
29	2.17	0.16	2.02	0.28	3.56	5.38	4.49	1.08
30	2.17	0.15	2.04	0.28	3.54	5.33	4.50	1.10
LSL	1.90	0.05	1.95	0.15	3.30	5.10	4.05	0.75
USL	2.45	0.20	2.20	0.40	3.95	5.60	4.60	1.50
MIN	2.11	0.14	2.01	0.27	3.47	5.33	4.49	1.06
MAX	2.18	0.17	2.05	0.29	3.56	5.41	4.55	1.12
AVG	2.17	0.16	2.02	0.28	3.52	5.36	4.52	1.09

6.3 Tests description

Test name	Description	Purpose
Die Oriented		
HTRB High Temperature Reverse Bias	The device is stressed in static configuration, trying to satisfy as much as possible the following conditions: <ul style="list-style-type: none"> - Low power dissipation - Max. supply voltage compatible with diffusion process and internal circuitry limitations. Forward: device is forward biased with a current fixed and adjusted to reach the targeted junction temperature	To determine the effects of bias conditions and temperature on solid state devices over time. It simulates the devices' operating condition in an accelerated way. To maximize the electrical field across either reverse-biased junctions or dielectric layers, in order to investigate the failure modes linked to mobile contamination, oxide ageing, layout sensitivity to surface effects. To assess active area and contacts integrity
Package Oriented		
PC Preconditioning	The device is submitted to a typical temperature profile used for surface mounting devices, after a controlled moisture absorption.	As stand-alone test: to investigate the moisture sensitivity level. As preconditioning before other reliability tests: to verify that the surface mounting stress does not impact on the subsequent reliability performance. The typical failure modes are "pop-corn" effect and delamination.
H3TRB High Humidity High Temperature Reverse Bias	The device is biased in static configuration minimizing its internal power dissipation, and stored at controlled conditions of ambient temperature and relative humidity.	To evaluate the package moisture resistance with electrical field applied, both electrolytic and galvanic corrosion are put in evidence.
TC Temperature Cycling	The device is submitted to cycled temperature excursions, between a hot and a cold chamber in air atmosphere.	To investigate failure modes related to the thermo-mechanical stress induced by the different thermal expansion of the materials interacting in the die-package system. Typical failure modes are linked to metal displacement, dielectric cracking, molding compound delamination, wire-bonds failure, die-attach layer degradation.
UHASt Unbiased Highly Accelerated Stress Test	The device is stored in saturated steam, at fixed and controlled conditions of pressure and temperature.	To investigate corrosion phenomena affecting die or package materials, related to chemical contamination and package hermeticity.
DPA Destructive Physical Analysis	Specific construction analysis on random parts that have successfully completed THB or TC.	To investigate on reliability stresses impact on delamination, corrosion and product construction integrity.
RSH Resistance to Solder Heat	Package is dipped by the leads in a solder bath after initial wet ageing (for SMDs only). Assessment by electrical test + no external crack	To simulate wave soldering process and verify that package will not be thermally damaged during this step.

Test name	Description	Purpose
DBT Dead Bug Test	To evaluate the wettability of the package leads. Good indicator to determine the bad solderability behavior	Components are glued up-side down on a substrate. Pins are wetted with a moderately activated flux. Then run once through the reflow oven with leadfree temperature profile. Visual inspection is performed with suitable tool.
SD Solderability	The purpose of this test method is to provide a referee condition for the evaluation of the solderability of terminations (including leads up to 0.125 inch in diameter) that will be assembled using tin lead eutectic solder.	This evaluation is based on the ability of these terminations to be wetted and to produce a suitable fillet when coated by tin lead eutectic solder. These procedures will test whether the packaging materials and processes used during the manufacturing operations process produce a component that can be successfully soldered to the next level assembly using tin lead eutectic solder. A preconditioning test is included in this test method, which degrades the termination finish to provide a guard band against marginal finish.
Functional Tests		
RS Repetitive Surges	The device is submitted to a reverse current peak: I_{pp} , which depends of the current holding of the product.	To evaluate the holding of the component to a high electrical field. Short circuit or hot point is expected as failure mechanism.

(1) ADG: Automotive and Discrete Group

PCN Product/Process Change Notification			
Transfer of Assembly and Test line for TVS products housed in SMA & SMB packages			
Notification number:	PDP/24/14700	Issue Date	12-Apr-2024
Issued by	Sophie da Silva		
Product series affected by the change	SMAJxxx SM6Txxx SMBJxxx		
Type of change	Transfer		
Description of the change The production of TVS products housed in SMA & SMB package currently located at subcontractor in China will be transferred to new plant location (same subcontractor and same city) in China.			
Reason for change Due to plant rationalization at subcontractor level, STMicroelectronics started new plant qualification to support TVS products business continuity.			
Former versus changed product:	The changed products do not present modified electrical, dimensional or thermal parameters, leaving unchanged the current information published in the product datasheet. The Moisture Sensitivity Level of the part (according to the IPC/JEDEC JSTD-020D standard) remains unchanged. The footprint recommended by ST remains the same. There is no change in the packing modes and the standard delivery quantities either. The products remain in full compliance with the ST ECOPACK®2 grade (so called “halogen-free”).		
Disposition of former products Delivery of current products will be done until stock depletion.			

(1) ADG: Automotive and Discrete Group

Marking and traceability			
Traceability of the change will be ensured by Finished Good/Type print on carton labels.			
Commercial part number/Order code	Former Finished Good/Type	New Finished Good/Type	
SMBJ70CA-TR	SMBJ70CAH-TR/YS	Ending with /HR SMBJ70CAH-TR/HR	
Qualification completion date		12-Apr-2024	
Forecasted sample availability			
Product family	Sub-family	Commercial part Number	Availability date
PROTECTION	SMA	SMAJ33A-TR	Wk18-2024
PROTECTION	SMB	SMBJ33A-TR	Wk18-2024
PROTECTION	SMB	SMBJ70CA-TR	Wk18-2024
For sample(s) request, please inform FSE (Field Sales Engineer) in order to insert corresponding Non-Standard Samples Order (a single Commercial Product for each request) with PCN reference as additional information.			
Change implementation schedule			
Sales-types	Estimated production start	Estimated first shipments	
Finished Good	W16-2024	W29-2024	
Comments:	With early PCN acceptance, shipments could be anticipated		
Customer's feedback			
Please contact your local ST sales representative or quality contact for requests concerning this change notification. Absence of acknowledgement of this PCN within 30 days of receipt will constitute acceptance of the change. Absence of additional response within 90 days of receipt of this PCN will constitute acceptance of the change.			
Qualification program and results	24014QRP Attached		

(1) ADG: Automotive and Discrete Group

Impacted Commercial Products		
SMA package	SMB package	
SMAJ12A-TR	SM6T15A	SMBJ15CA-TR
SMAJ12CA-TR	SM6T15CA	SMBJ16A-TR
SMAJ13A-TR	SM6T18A	SMBJ18A-TR
SMAJ13CA-TR	SM6T18CA	SMBJ18CA-TR
SMAJ15A-TR	SM6T22A	SMBJ20A-TR
SMAJ15CA-TR	SM6T22CA	SMBJ20CA-TR
SMAJ18A-TR	SM6T24A	SMBJ22A-TR
SMAJ18CA-TR	SM6T24CA	SMBJ22CA-TR
SMAJ20A-TR	SM6T27A	SMBJ24A-TR
SMAJ24A-TR	SM6T27CA	SMBJ24CA-TR
SMAJ24CA-TR	SM6T30A	SMBJ26A-TR
SMAJ26A-TR	SM6T30CA	SMBJ26CA-TR
SMAJ26CA-TR	SM6T33A	SMBJ28A-TR
SMAJ28A-TR	SM6T33CA	SMBJ28CA-TR
SMAJ28CA-TR	SM6T36A	SMBJ30A-TR
SMAJ30A-TR	SM6T36CA	SMBJ30CA-TR
SMAJ30CA-TR	SM6T39A	SMBJ33A-TR
SMAJ33A-TR	SM6T39CA	SMBJ33CA-TR
SMAJ33CA-TR	SM6T56CA	SMBJ36CA-TR
SMAJ40CA-TR	SM6T68CA	SMBJ40CA-TR
SMAJ43CA-TR	SMBJ12A-TR	SMBJ48CA-TR
SMAJ48CA-TR	SMBJ12CA-TR	SMBJ58CA-TR
SMAJ58CA-TR	SMBJ13CA-TR	SMBJ70CA-TR
SMAJ70CA-TR	SMBJ15A-TR	

Qualification Report

Plant transfer for TVS (SMA and SMB packages)

General Information		Locations	
Product Line	Protection	Wafer Fab	ST Tours (France)
Product Description	Industrial TVS products SMA and SMB packages	Assembly Plant	Subcontractor (990C) - China
Product Perimeter	SMAJxxx SM6Txxx SMBJxxx	Reliability Lab	ST Tours (France)
Product Group	APMS		
Product Division	Discrete & Filter		
Packages	SMA - SMB		
Maturity level step	Qualified	Reliability Assessment	Compliant

DOCUMENT INFORMATION

Version	Date	Pages	Prepared by	Approved by	Comments
1.0	April 12, 2024	20	A. KHEDIM	Digitally signed by Timothée PINGAULT Date: 2024.04.12 14:27:06 +02'00'	Document creation

Note: This report is a summary of the qualification trials performed in good faith by STMicroelectronics in order to evaluate the potential risks during the product life using a set of defined test methods. This report does not imply for STMicroelectronics expressly or implicitly any contractual obligations other than as set forth in STMicroelectronics general terms and conditions of Sale. This report and its contents shall not be disclosed to a third party without previous written agreement from STMicroelectronics.

TABLE OF CONTENTS

1	APPLICABLE AND REFERENCE DOCUMENTS	3
2	GLOSSARY	3
3	RELIABILITY EVALUATION OVERVIEW	4
3.1	OBJECTIVES	4
3.2	CONCLUSION	5
4	DEVICE CHARACTERISTICS	6
4.1	DEVICE DESCRIPTION	6
4.2	CONSTRUCTION NOTE	8
5	TESTS PLAN AND RESULTS SUMMARY	9
5.1	TEST VEHICLES	9
5.2	TEST PLAN	10
5.3	RESULTS SUMMARY	13
6	ANNEXES	15
6.1	PARAMETRIC VERIFICATION	15
6.2	PHYSICAL DIMENSIONS	15
6.3	TESTS DESCRIPTION	19

1 APPLICABLE AND REFERENCE DOCUMENTS

Document reference	Short description
JESD 47	Stress-Test-Driven Qualification of Integrated Circuits
JESD 94	Application specific qualification using knowledge based test methodology
JESD 22	Reliability test methods for packaged devices
MIL-STD-750C	Test method for semiconductor devices

2 GLOSSARY

DBT	Dead bug test
DPA	Destructive Physical Analysis
GD	Generic Data
H3TRB	High Humidity High Temperature Reverse Bias
HTRB	High Temperature Reverse Bias
PD	Physical Dimensions
PV	Parametric Verification
RS	Repetitive Surges
RSH	Resistance to solder heat
SD	Solderability
SS	Sample Size
TC	Temperature Cycling
UHAST	Unbiased Highly Accelerated Stress Test

3 RELIABILITY EVALUATION OVERVIEW

3.1 Objectives

Due to plant rationalization at subcontractor level, STMicroelectronics has qualified a new plant to support TVS products business continuity.

The objective is to qualify the plant transfer (same subcontractor, no change in BOM, lead frame, plating, resin nor tools) of SMA and SMB lines.

The impacted products are the following:

- 400W & 600W TVS embedded in SMA package,
- 600W TVS embedded in SMB package.

Commercial Product	Package	Comment (optional)
SMAJxxx SM6Txxx SMBJxxx	SMA SMA SMB	Industrial grade

Impacted products		
SMAJ12A	SM6T15A	SMBJ12A
SMAJ12CA	SM6T15CA	SMBJ12CA
SMAJ13A	SM6T18A	SMBJ13CA
SMAJ13CA	SM6T18CA	SMBJ15A
SMAJ15A	SM6T22A	SMBJ15CA
SMAJ15CA	SM6T22CA	SMBJ16A
SMAJ18A	SM6T24A	SMBJ18A
SMAJ18CA	SM6T24CA	SMBJ18CA
SMAJ20A	SM6T27A	SMBJ20A
SMAJ24A	SM6T27CA	SMBJ20CA
SMAJ24CA	SM6T30A	SMBJ22ATR
SMAJ26A	SM6T30CA	SMBJ22CA
SMAJ26CA	SM6T33A	SMBJ24A
SMAJ28A	SM6T33CA	SMBJ24CA
SMAJ28CA	SM6T36A	SMBJ26A
SMAJ30A	SM6T36CA	SMBJ26CA
SMAJ30CA	SM6T39A	SMBJ28A
SMAJ33A	SM6T39CA	SMBJ28CA
SMAJ33CA	SM6T56CA	SMBJ30A
SMAJ40CA	SM6T68CA	SMBJ30CA
SMAJ43CA		SMBJ33A
SMAJ48CA		SMBJ33CA
SMAJ58CA		SMBJ36CA
SMAJ70CA		SMBJ40CA
		SMBJ48CA
		SMBJ58CA
		SMBJ70CA

The reliability test methodology used follows the JESD47: "Stress Test driven Qualification Methodology".

The reliability tests ensuing are:

- TC to ensure the mechanical robustness of the products.
- HTRB to evaluate the risk of contamination from the resin and the assembly process versus the die layout sensitivity.
- H3TRB, UHAST to check the robustness to corrosion and the good package hermeticity.
- RSH, Solderability and DBT to check compatibility of package with customer assembly.
- Functional test: Repetitive IPP to verify robustness of device submitted to rated Ipp (as per data sheet)

For some tests, similarity methodology is used. See 5.1 "comments" for more details about similarities.

3.2 Conclusion

Qualification Plan requirements have been fulfilled without exception. Reliability tests have shown that the devices behave correctly against environmental tests (no failure). Moreover, the stability of electrical parameters during the accelerated tests demonstrates the robustness of the products and safe operation, which is consequently expected during their lifetime.

Based on these results, TVS in SMD packages are compliant with JESD47.

4 DEVICE CHARACTERISTICS

4.1 Device description

Example datasheet of TVS SMA package (SMAJ70CA)



SMAJxxA, SMAJxxCA

Datasheet

400 W TVS in SMA

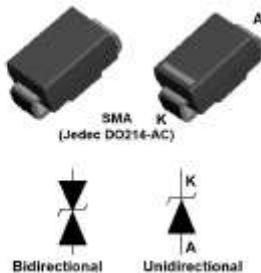

Features

- Peak pulse power:
 - 400 W (10/1000 μ s)
 - 2.3 kW (8/20 μ s)
- Stand-off voltage range from 5 V to 188 V
- Unidirectional and bidirectional types
- Low leakage current:
 - 0.2 μ A at 25 °C
 - 1 μ A at 85 °C
- Operating T_J max: 150 °C
- JEDEC registered package outline

Complies with the following standards

- UL94, V0
- J-STD-020 MSL level 1
- J-STD-002, JESD 22-B102 E3 and MIL-STD-750, method 2028 solderable matte tin plated leads
- JESD-201 class 2 whisker test
- IPC7531 footprint
- JEDEC registered package outline
- IEC 61000-4-4 level 4:
 - 4 kV
- IEC 61000-4-2, C = 150 pF - R = 330 Ω exceeds level 4:
 - 30 kV (air discharge)
 - 30 kV (contact discharge)

Description

The SMAJ series is designed to protect sensitive equipment against electrostatic discharges according to IEC 61000-4-2 and MIL STD 883, method 3015, and electrical overstress according to IEC 61000-4-4 and 5. This device is more generally used against surges below 600 W (10/1000 μ s).

The Planar technology makes it compatible with high-end circuits where low leakage current and high junction temperature are required to provide long term reliability and stability. SMAJ devices are packaged in SMA (SMA footprint in accordance with IPC 7531 standard).

Product status links

[SMAJ5.0A, SMAJ5.0CA,](#)
[SMAJ6.0A, SMAJ6.0CA,](#)
[SMAJ6.5A, SMAJ6.5CA,](#)
[SMAJ8.5A, SMAJ8.5CA,](#)
[SMAJ10A, SMAJ10CA,](#)
[SMAJ12A, SMAJ12CA,](#)
[SMAJ13A, SMAJ13CA,](#)
[SMAJ15A, SMAJ15CA,](#)
[SMAJ18A, SMAJ18CA,](#)
[SMAJ20A, SMAJ20CA,](#)
[SMAJ24A, SMAJ24CA,](#)
[SMAJ26A, SMAJ26CA,](#)
[SMAJ28A, SMAJ28CA,](#)
[SMAJ30A, SMAJ30CA,](#)
[SMAJ33A, SMAJ33CA,](#)
[SMAJ40A, SMAJ40CA,](#)
[SMAJ43A, SMAJ43CA,](#)
[SMAJ48A, SMAJ48CA,](#)
[SMAJ58A, SMAJ58CA,](#)
[SMAJ70A, SMAJ70CA,](#)
[SMAJ85A, SMAJ85CA,](#)
[SMAJ100A, SMAJ100CA,](#)
[SMAJ130A, SMAJ130CA,](#)
[SMAJ154A, SMAJ154CA,](#)
[SMAJ170A, SMAJ170CA,](#)
[SMAJ188A, SMAJ188CA.](#)

Example datasheet of TVS SMB package (SMBJ33A)



SMBJ

Datasheet

600 W TVS in SMB

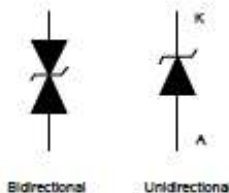

Features

- Peak pulse power: 600 W (10/1000 μ s) and 4 kW (8/20 μ s)
- Stand-off voltage range from 5 V to 188 V
- Unidirectional and bidirectional types
- Low leakage current: 0.2 μ A at 25 °C and 1 μ A at 85 °C
- Operating T_j max: 150 °C
- High power capability at T_j max.: up to 515 W (10/1000 μ s)
- Lead finishing: matte tin plating

Complies with the following standards

- UL94, V0
- J-STD-020 MSL level 1
- J-STD-002, JESD 22-B102 E3 and MIL-STD-750, method 2026 solderable matte tin plated leads
- JESD-201 class 2 whisker test
- IPC7531 footprint
- JEDEC registered package outline
- IEC 61000-4-4 level 4:
 - 4 kV
- IEC 61000-4-2, C = 150 pF - R = 330 Ω exceeds level 4:
 - 30 kV (air discharge)
 - 30 kV (contact discharge)

Description

The SMBJ series are designed to protect sensitive equipment against electrostatic discharges according to IEC 61000-4-2 and MIL STD 883, method 3015, and electrical overstress according to IEC 61000-4-4 and 5. This device is more generally used against surges below 600 W (10/1000 μ s).

The Planar technology makes it suitable for high-end equipment and SMPS where low leakage current and high junction temperature are required to provide reliability and stability over time.

The SMBJ series are packaged in SMB.

Product status link	
SMBJ	SMBJ5.0A, SMBJ5.0CA, SMBJ6.0A, SMBJ6.0CA, SMBJ6.5A, SMBJ6.5CA, SMBJ8.5A, SMBJ8.5CA, SMBJ10A, SMBJ10CA, SMBJ12A, SMBJ12CA, SMBJ13A, SMBJ13CA, SMBJ15A, SMBJ15CA, SMBJ16A, SMBJ16CA, SMBJ18A, SMBJ18CA, SMBJ20A, SMBJ20CA, SMBJ22A, SMBJ22CA, SMBJ24A, SMBJ24CA, SMBJ26A, SMBJ26CA, SMBJ28A, SMBJ28CA, SMBJ30A, SMBJ30CA, SMBJ33A, SMBJ33CA, SMBJ36A, SMBJ36CA, SMBJ40A, SMBJ40CA, SMBJ43A, SMBJ43CA, SMBJ48A, SMBJ48CA, SMBJ58A, SMBJ58CA, SMBJ64A, SMBJ64CA, SMBJ70A, SMBJ70CA, SMBJ85A, SMBJ85CA, SMBJ100A, SMBJ100CA, SMBJ130A, SMBJ130CA, SMBJ154A, SMBJ154CA, SMBJ170A, SMBJ170CA, SMBJ188A, SMBJ188CA

4.2 Construction Note

400W, 600W TVS package SMA qualification	
Wafer/Die fab. information	
Wafer fab manufacturing location	ST Tours - France
Technology / Process family	Discrete Transil
Wafer Testing (EWS) information	
Electrical testing manufacturing location	ST Tours - France
Assembly information	
Assembly site	Subcontractor (990C) - China
Package description	SMA
Molding compound	ECOPACK@2 molding compound
Lead finishing material	Lead free (pure Tin)
Final testing information	
Testing location	Subcontractor (990C) - China

600W TVS SMB qualification	
Wafer/Die fab. information	
Wafer fab manufacturing location	ST Tours - France
Technology / Process family	Discrete Transil
Wafer Testing (EWS) information	
Electrical testing manufacturing location	ST Tours - France
Assembly information	
Assembly site	Subcontractor (990C) - China
Package description	SMB
Molding compound	ECOPACK@2 molding compound
Lead finishing material	Lead free (pure Tin)
Final testing information	
Testing location	Subcontractor (990C) - China

5 TESTS PLAN AND RESULTS SUMMARY

5.1 Test vehicles

Lot #	Finish Good	Package	Comments
Lot 1	SMAJ70CA	SMA	Qualification lot
Lot 2	SMBJ33A	SMB	Qualification lot
Lot 3	SMBJ33A	SMB	Qualification lot
Lot 4	SMBJ70CA	SMB	Qualification lot
Lot 5	SMBJ70CA	SMB	Qualification lot
Lot 6	SMAJ33A	SMA	Qualification lot
Lot 7	SMAJ70CA	SMA	Qualification lot
Lot 8	SMBJ33A	SMB	Qualification lot

Detailed results in the chapter below will refer to these references.

5.2 **Test plan**

Stress	Abrv	Reference	Lot	SS	Comments	Test plan
Pre and Post-Stress Electrical Test	TEST	User specification or supplier's standard Specification	All qualification parts tested per the requirements of the appropriate device specification.			
Pre-conditioning	PC	J-STD-020 JESD22-A113	All qualification parts tested per the requirements of the appropriate device specification.		As per targeted MSL Not applicable for PTH and WLCSP without coating	
MSL research	MSL	J-STD-020			Not applicable for PTH and WLCSP without coating	
External Visual	EV	JESD22B-101	All qualification parts tested per the requirements of the appropriate device specification.		Done during Assembly → Test & Finish inspection	
Parametric Verification	PV	User specification				
High Temperature Reverse Bias	HTRB	MIL-STD-750-1 M1038 Method A (for diodes, rectifiers and Zeners) M1039 Method A (for transistors)	Lot 1 Lot 2 Lot 3 Lot 4 Lot 5 Lot 6 Lot 7 Lot 8	45 45 45 45 45 45 45 45		X
AC blocking voltage	ACBV	MIL-STD-750-1 M1040 Test condition A			Required for Thyristor only. Alternative to HTRB	
High Temperature Forward Bias	HTFB	JESD22 A-108			Not required, applicable only to LEDS Alternative to HTRB	
High Temperature Operating Life	HTOL				Covered by HTRB or ACBV	
Steady State Operational	SSOP	MIL-STD-750-1 M1038 Test condition B			Required for Voltage Regulator (Zener) only.	
High Temperature Gate Bias	HTGB	JESD 22A-108			Required for Power MOSFET – IGBT only.	
High Temperature Storage Life	HTSL	JESD22 A-103			Covered by H3TRB	
Temperature Humidity Storage	THS	JESD22 A-118			Covered by H3TRB	
Temperature Cycling	TC	JESD22A-104	Lot 1 Lot 2 Lot 3 Lot 4 Lot 5 Lot 6 Lot 7 Lot 8	30 30 30 30 30 25 25 25		X
Temperature Cycling Hot Test	TCHT	JESD22A-104			Required for Power MOSFET – IGBT only.	
Temperature Cycling Delamination Test	TCDT	JESD22A-104 J-STD-035			Required for Power MOSFET – IGBT only. Alternative to TCHT	
Wire Bond Integrity	WBI	MIL-STD-750 Method 2037			For dissimilar metal bonding systems only	
Unbiased Highly Accelerated Stress Test	UHASt	JESD22A-118 or A101	Lot 1 Lot 2 Lot 3	77 77 77		X

Stress	Abrv	Reference	Lot	SS	Comments	Test plan
			Lot 4 Lot 5 Lot 6 Lot 7 Lot 8	77 77 25 25 25		
Autoclave	AC	JESD22A-102			Alternative to UHAST	
Highly Accelerated Stress Test	HAST	JESD22A-110			Covered by H3TRB (same failure mechanisms activation).	
High Humidity High Temperature Reverse Bias	H3TRB	JESD22A-101	Lot 1 Lot 2 Lot 3 Lot 4 Lot 5 Lot 6 Lot 7 Lot 8	25 25 25 25 25 25 25 25	Alternative to HAST	X
High Temperature High Humidity Bias	HTHH B	JED22A-101			Not required, LED only	
Intermittent Operational Life / Thermal Fatigue	IOL	MIL-STD-750 Method 1037			For power devices. Not required for Transient Voltage Suppressor (TVS) parts	
Power and Temperature Cycle	PTC	JED22A-105			For power devices. Not required for Transient Voltage Suppressor (TVS) parts Perform PTC if $\Delta T_j > 100^\circ\text{C}$ cannot be achieved with IOL Alternative to IOL	
ESD Characterization	ESD HBM	AEC Q101-001 and 005				
ESD Characterization	ESD CDM	AEC Q101-001 and 005				
Destructive Physical Analysis	DPA	AEC-Q101-004 Section 4			After H3TRB and TC	X
Physical Dimension	PD	JESD22B-100				
Terminal Strength	TS	MIL-STD-750 Method 2036			Required for leaded parts only	
Resistance to Solvents	RTS	JESD22B-107			Not applicable for Laser Marking	
Constant Acceleration	CA	MIL-STD-750 Method 2006			Required for hermetic packaged parts only.	
Vibration Variable Frequency	VVF	JESD22B-103			Required for hermetic packaged parts only.	
Mechanical Shock	MS	JESD22 B-104			Required for hermetic packaged parts only.	
Hermeticity	HER	JESD22A-109			Required for hermetic packaged parts only.	
Resistance to Solder Heat	RSH	JESD22 A-111 (SMD)	Lot 1 Lot 4 Lot 6 Lot 7	30 30 30		X
Solderability	SD	J-STD-002 JESD22B102	Lot 5	4*15		X
Dead Bug Test	DBT	ST Internal specification	Lot 1 Lot 4	2*30 2*30		X
Thermal Resistance	TR	JESD24-3, 24-4, 24-6 as appropriate			Required in case of process change. Not applicable to protection device as no limit specified in the datasheet	



Stress	Abrv	Reference	Lot	SS	Comments	Test plan
Wire Bond Strength	WBS	MIL-STD-750 Method 2037			Covered during workability trials	
Bond Shear	BS	AEC-Q101-003			Covered during workability trials	
Die Shear	DS	MIL-STD-750 Method 2017			Not Applicable to parts with solder paste die attach	
Unclamped Inductive Switching	UIS	AEC-Q101-004 section 2			Required for Power MOS and internally clamped IGBTs only	
Dielectric Integrity	DI	AEC-Q101-004 section 3			Required for Power MOSFET – IGBT only.	
Short Circuit Reliability Characterization	SCR	AEC-Q101-006			Required for smart power parts only	
Whisker Growth Evaluation	WG	AEC-Q005 JESD201				
Early Life Failure Rate	ELFR	JESD74			Recommended for new techno development in case of identified failure mechanism	
Functional Test (in rush, di/dt,...)	FT	Internal specification				
Repetitive Surge	RS	Internal specification	Lot 1 Lot 2 Lot 3 Lot 4 Lot 5 Lot 6 Lot 7 Lot 8	20 20 20 20 20 20 20 20	Required for protection devices only.	X

Low Temperature Storage	LTS	JESD-22 A119: 209			AQG324 test for Modules	
Thermal shock test	TST	JESD22-A104			AQG324 test for Modules	
Power Cycling (seconds)	PCsec	MIL-STD750-1 Method1037			AQG324 test for Modules	
Power Cycling (minutes)	PCmin	MIL-STD750-1 Method1037			AQG324 test for Modules	
Mechanical shock	MS	IEC 600068-2-27			AQG324 test for Modules	
Vibration	V	IEC60068-2-6			AQG324 test for Modules	

5.3 Results summary

Test	PC	Std ref.	Conditions	Total	Steps	Results / Lot								
						Fail/s.s.								
						SMAJ70CA	SMBJ33A	SMBJ70CA	SMBJ70CA	SMAJ33A	SMAJ70CA	SMAJ33A	SMAJ70CA	SMBJ33A
						Lot 1	Lot 2	Lot 3	Lot 4	Lot 5	Lot 6	Lot 7	Lot 8	Lot 8
Pre-and Post Electrical Test	-	ST datasheet	IR, VBR, VF parameters according to product datasheet	1530	-									
External Visual	-	JESD22B-101	All qualification parts submitted for testing passed External & Visual inspection during manufacturing process											0/1530
Parametric Verification	-	ST datasheet	Over part temperature range (note1)											
			Junction											
HTRB	N	MIL-STD-750-1 M1038 Method A	Temperature=150°C Temperature=150°C Tension=Vrm	315	1000h	0/45	0/45	0/45	0/45	0/45	0/45	0/45	0/45	0/45
TC	Y	JESD22-A104	Frequency (cy/h)=2cy/h Temperature (high)=150°C Temperature (low)=-65°C	300	500cy	0/45	0/45	0/45	0/45	0/45	0/25	0/25	0/25	0/25
RSH	N	JESD22A-111 (SMD) / JESD22B-106 (PTH)	Temperature=260°C Time (on)=10s	120	Measure after dipping	0/30			0/30		0/30		0/30	
H3TRB	Y	JESD22-A101	Humidity (HR)=85% Temperature=85°C Tension= Vrm (max 100V)	175	1000h	0/25	0/25	0/25	0/25	0/25	0/25	0/25	0/25	0/25
UHAST	Y	JESD22 A-118	Humidity (HR)=85% Pressure=2.3bar Temperature=130°C	460	96h	0/77	0/77	0/77	0/77	0/77	0/25	0/25	0/25	0/25
Solderability	N	J-STD-002 (test B SMD)	Wet aging = 8h Metal (solder) = SnPb No data dream = 1 No elec Measurement=1 Temperature=220°C	15	Visual inspection					0/15				



Test	PC	Std ref.	Conditions	Total	Steps	Results / Lot								
						SMA/70CA Lot 1	SMB/33A Lot 2	SMB/33A Lot 3	SMB/70CA Lot 4	SMB/70CA Lot 5	SMA/33A Lot 6	SMA/70CA Lot 7	SMB/33A Lot 8	
Solderability	N	J-STD-002 (test B SMD)	Dry aging = 16h Metal (solder) = SnAgCu No data dream = 1 No elec Measurement=1 Temperature=245°C	15	Visual inspection					0/15				
Solderability	N	J-STD-002 (test B SMD)	Wet aging = 8h Metal (solder) = SnAgCu No data dream = 1 No elec Measurement=1 Temperature=245°C	15	Visual inspection					0/15				
Solderability	N	J-STD-002 (test B SMD)	Dry aging = 16h Metal (solder) = SnPb No data dream = 1 No elec Measurement=1 Temperature=220°C	15	Visual inspection					0/15				
DBT	N	DM00112629	No Data Dream=1 No Elec Measurement=1 Reflow=1	60	Visual inspection	0/30				0/30				
DBT	N	DM00112629	No Data Dream=1 No Elec Measurement=1 Reflow=1	60	Visual inspection	0/30				0/30				
Functional test														
Repetitive Surge	Y	ADCS0060282	IPP=IPP datasheet Pulse delay=0.01ms Time between surge=60s	160	50 surges	0/20	0/20	0/20	0/20	0/20	0/20	0/20	0/20	0/20

Note 1: These data are indicative values given as information only. Please note that the ST guarantee is the compliance of the products to the ST datasheet. Parameters distributions are not considered as a ST guarantee under any circumstances.
Please note that these electrical parameters are 100% tested at 25°C at Final stage of back-end manufacturing before deliveries to customers.”

6 ANNEXES

6.1 Parametric Verification

SMAJ33A

Characterization SMAJ33A							
Date : 05/04/2024							
Ref : 23515A							
Lab : ST Tours Characterization Lab							
TEST	VBR	IRM	IRM	VCL 10/1000 μ s	RD	VCL 8/20 μ s	RD
EQUIPMENT	TESEC	TESEC	TESEC	TESEC	TEST CALCULES	TESEC	TESTS_CALCULES
Condition 1	25°C	25°C	85°C	25°C	25°C	25°C	25°C
Condition 2	IR=1mA	VRM=33V	VRM=33V	IPP=7.5A	IF1=3.75A	IPP=33A	IF1=16.5A
Condition 3					IF2=7.5A		IF2=33A
Condition 4					VR1= 1-VCL 10/1000 μ s		VR1= 1-VCL 8/20 μ s
Condition 5					VR2= 2-VCL 10/1000 μ s		VR2= 2-VCL 8/20 μ s
Min. Datasheet	36.7						
Typ. Datasheet	38.6						
Max. Datasheet		0.2 μ A	1 μ A	53.3	1.70	69.7	0.884ohm
Comments	Direct	Direct	Direct	Direct	Direct	Direct	Direct
UNIT	V	nA	nA	V	Ohm	V	Ohm
N	30	30	30	30	30	30	30
Min	37.83	1.27	3.34	45.9	0.96	48.69	0.324
Max	39.13	10.23	47.13	48.3	1.2	52.71	0.379
Avg.	38.49	4.48	20.11	46.8	1.04	50.5	0.341
(*)These data are indicative values given as information only. Please note that the ST guarantee is the compliance of the products to the ST datasheet. Parameters distributions are not considered as a ST guarantee under any circumstances. Please note that these electrical parameters are 100% tested at 25°C at Final stage of back-end manufacturing before deliveries to customers							

SMBJ33A

Characterization SMBJ33A							
Date : 05/04/2024							
Ref : 23534A							
Lab : ST Tours Characterization Lab							
TEST	VBR	IRM	IRM	VCL 10/1000 μ s	RD	VCL 8/20 μ s	RD
EQUIPMENT	TESEC	TESEC	TESEC	TESEC	TEST CALCULES	TESEC	TESTS_CALCULES
Condition 1	25°C	25°C	85°C	25°C	25°C	25°C	25°C
Condition 2	IR=1mA	VRM=33V	VRM=33V	IPP=11.8A	IF1=5.9A	IPP=57A	IF1=28.5A
Condition 3					IF2=11.8A		IF2=57A
Condition 4					VR1= 1-VCL 10/1000 μ s		VR1= 1-VCL 8/20 μ s
Condition 5					VR2= 2-VCL 10/1000 μ s		VR2= 2-VCL 8/20 μ s
Min. Datasheet	36.7						
Typ. Datasheet	38.6						
Max. Datasheet		0.2 μ A	1 μ A	53.3	1.08	69.7	0.512ohm
Comments	Direct	Direct	Direct	Direct	Direct	Direct	Direct
UNIT	V	nA	nA	V	Ohm	V	Ohm
N	30	30	30	30	30	30	30
Min	38.41	1.975	6.975	46.2	0.576	51.32	0.191
Max	40	7.863	11.93	48.3	0.83	54.08	0.225
Avg.	38.99	2.719	9.62	46.96	0.663	52.49	0.212
(*)These data are indicative values given as information only. Please note that the ST guarantee is the compliance of the products to the ST datasheet. Parameters distributions are not considered as a ST guarantee under any circumstances. Please note that these electrical parameters are 100% tested at 25°C at Final stage of back-end manufacturing before deliveries to customers							

SMBJ70CA

Characterization SMBJ70CA								
Date : 05/04/2024								
Ref : 23516A								
Lab : ST Tours Characterization Lab								
TEST	VBR	VBR	IRM	IRM	IRM	IRM		
EQUIPMENT	TESEC	TESEC	TESEC	TESEC	TESEC	TESEC		
Condition 1	25°C	25°C	25°C	25°C	85°C	85°C		
Condition 2	IR=1mA	IR=1mA	VRM=70V	VRM=70V	VRM=70V	VRM=70V		
Condition 3								
Condition 4								
Condition 5								
Min. Datasheet	77.8	77.8						
Typ. Datasheet	81.9	81.9						
Max. Datasheet			0,2µA	0,2µA	1µA	1µA		
Comments	Direct	Reverse	Direct	Reverse	Direct	Reverse		
UNIT	V	V	nA	nA	nA	nA		
N	30	30	30	30	30	30		
Min	79.98	80.12	1.074	0.952	4.42	2.393		
Max	83.17	82.25	26.86	27.91	46.83	40.78		
Avg.	81.37	81.15	6.687	9.846	19.109	20.215		
TEST	VCL 10/1000 µs	VCL 10/1000 µs	RD	RD	VCL 8/20 µs	VCL 8/20 µs	RD	RD
EQUIPMENT	TESEC	TESEC	TEST CALCULES	TEST CALCULES	TESEC	TESEC	TESTS_CALCULES	TESTS_CALCULES
Condition 1	25°C	25°C	25°C	25°C	25°C	25°C	25°C	25°C
Condition 2	IPP=5,5A	IPP=5,5A	IF1=2,75A	IF1=2,75A	IPP=27A	IPP=27A	IF1=13,5A	IF1=13,5A
Condition 3			IF2=5,5A	IF2=5,5A			IF2=27A	IF2=27A
Condition 4			VR1= 1-VCL 10/1000 µs	VR1= 1-VCL 10/1000 µs			VR1= 1-VCL 8/20 µs	VR1= 1-VCL 8/20 µs
Condition 5			VR2= 2-VCL 10/1000 µs	VR2= 2-VCL 10/1000 µs			VR2= 2-VCL 8/20 µs	VR2= 2-VCL 8/20 µs
Min. Datasheet								
Typ. Datasheet								
Max. Datasheet	113	113	4.91	4.91	146	146	2,2ohm	2,2ohm
Comments	Direct	Reverse	Direct	Reverse	Direct	Reverse	Direct	Reverse
UNIT	V	V	Ohm	Ohm	V	V	ohm	ohm
N	15	15	15	15	15	15	15	15
Min	95	94.9	2.109	2.472	98.08	98.08	0.611	0.603
Max	97.5	97.1	3.381	2.909	100.83	100.83	0.679	0.679
Avg.	96.04	95.9	2.766	2.71	99.48	99.48	0.642	0.6373
(**)These data are indicative values given as information only. Please note that the ST guarantee is the compliance of the products to the ST datasheet. Parameters distributions are not considered as a ST guarantee under any circumstances.								
Please note that these electrical parameters are 100% tested at 25°C at Final stage of back-end manufacturing before deliveries to customers								

6.2 Physical Dimensions

SMA package dimensions

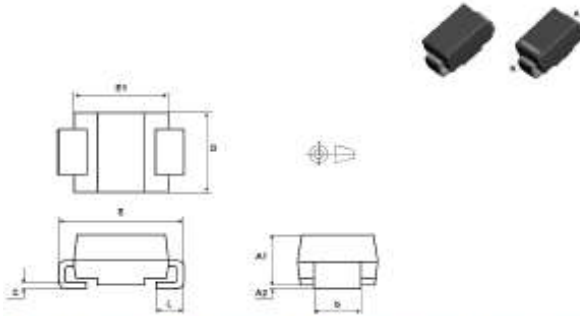

Ref.	Millimeters	
	Min.	Max.
A1	1.90	2.45
A2	0.05	0.20
b	1.25	1.65
c	0.15	0.40
D	2.25	2.90
E	4.80	5.35
E1	3.95	4.60
L	0.75	1.50

Spec	A1	A2	b	c	D	E	E1	L
MIN:	1.90	0.05	1.25	0.15	2.25	4.80	3.95	0.75
MAX:	2.45	0.20	1.65	0.40	2.90	5.35	4.60	1.50
1	2.134	0.142	1.549	0.280	2.818	5.069	4.380	1.066
2	2.107	0.150	1.536	0.250	2.825	5.065	4.379	1.055
3	2.138	0.133	1.539	0.268	2.800	5.080	4.383	1.040
4	2.129	0.113	1.551	0.277	2.806	5.128	4.371	1.037
5	2.124	0.124	1.537	0.271	2.810	5.115	4.364	1.051
6	2.093	0.137	1.528	0.261	2.817	5.062	4.371	1.055
7	2.116	0.144	1.551	0.275	2.802	5.117	4.375	1.039
8	2.087	0.104	1.539	0.266	2.810	5.131	4.379	1.023
9	2.132	0.118	1.543	0.273	2.804	5.080	4.382	1.041
10	2.132	0.122	1.541	0.280	2.814	5.133	4.375	1.021
11	2.137	0.142	1.535	0.271	2.801	5.088	4.379	1.021
12	2.089	0.132	1.528	0.261	2.806	5.109	4.371	1.016
13	2.146	0.137	1.533	0.267	2.820	5.123	4.380	1.072
14	2.136	0.112	1.544	0.270	2.818	5.096	4.366	1.045
15	2.115	0.132	1.533	0.271	2.813	5.092	4.368	1.042
16	2.107	0.119	1.532	0.276	2.837	5.097	4.382	1.039
17	2.125	0.130	1.541	0.269	2.819	5.104	4.375	1.020
18	2.132	0.134	1.532	0.265	2.803	5.112	4.376	1.045
19	2.139	0.142	1.528	0.268	2.827	5.113	4.379	1.029
20	2.121	0.118	1.529	0.263	2.804	5.127	4.383	1.016
21	2.130	0.140	1.543	0.271	2.823	5.127	4.368	1.040
22	2.146	0.136	1.555	0.273	2.814	5.079	4.362	1.020
23	2.114	0.130	1.536	0.263	2.799	5.102	4.376	1.036
24	2.126	0.140	1.549	0.272	2.820	5.133	4.380	1.037
25	2.133	0.137	1.537	0.272	2.820	5.088	4.375	1.052
26	2.099	0.116	1.530	0.268	2.809	5.177	4.389	1.030
27	2.089	0.107	1.524	0.266	2.820	5.075	4.383	1.063
28	2.108	0.111	1.547	0.274	2.825	5.079	4.376	1.074
29	2.100	0.105	1.531	0.274	2.814	5.110	4.370	1.058
30	2.140	0.134	1.540	0.268	2.816	5.110	4.385	1.042
MIN	2.087	0.104	1.524	0.250	2.799	5.062	4.362	1.016
MAX	2.146	0.150	1.555	0.280	2.837	5.177	4.389	1.074
AVG	2.121	0.128	1.538	0.269	2.814	5.104	4.376	1.041

SMB package dimensions

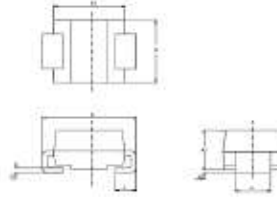
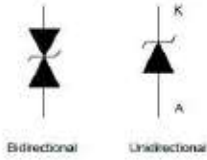

Ref	Dimension			
	Millimeters		Inches ⁽¹⁾	
	Min.	Max.	Min.	Max.
A1	1.90	2.45	0.0748	0.0969
A2	0.05	0.30	0.0020	0.0118
b	1.95	2.20	0.0768	0.0867
c	0.15	0.40	0.0059	0.0157
D	3.30	3.95	0.1299	0.1556
E	5.10	5.60	0.2008	0.2205
E1	4.05	4.30	0.1594	0.1693
L	0.75	1.50	0.0295	0.0591

Cote	A1	A2	b	c	D	E	E1	L
1	2.18	0.16	2.04	0.28	3.52	5.34	4.55	1.09
2	2.14	0.17	2.03	0.29	3.51	5.38	4.51	1.11
3	2.18	0.17	2.03	0.28	3.51	5.35	4.55	1.08
4	2.17	0.16	2.01	0.29	3.52	5.38	4.53	1.10
5	2.11	0.16	2.03	0.29	3.51	5.35	4.51	1.12
6	2.14	0.14	2.02	0.29	3.53	5.34	4.55	1.10
7	2.16	0.15	2.02	0.28	3.47	5.33	4.51	1.09
8	2.17	0.16	2.02	0.28	3.50	5.35	4.53	1.06
9	2.17	0.16	2.02	0.27	3.51	5.36	4.51	1.09
10	2.17	0.15	2.01	0.28	3.49	5.34	4.51	1.11
11	2.17	0.16	2.03	0.28	3.50	5.36	4.52	1.07
12	2.17	0.16	2.03	0.28	3.51	5.37	4.54	1.07
13	2.16	0.15	2.04	0.28	3.52	5.36	4.51	1.08
14	2.18	0.16	2.02	0.29	3.51	5.39	4.54	1.07
15	2.17	0.14	2.02	0.28	3.50	5.38	4.53	1.09
16	2.17	0.16	2.02	0.29	3.53	5.36	4.52	1.10
17	2.17	0.16	2.05	0.27	3.52	5.38	4.51	1.10
18	2.18	0.15	2.03	0.28	3.53	5.37	4.50	1.11
19	2.15	0.15	2.02	0.27	3.50	5.37	4.52	1.11
20	2.17	0.16	2.02	0.28	3.53	5.37	4.53	1.11
21	2.16	0.16	2.01	0.28	3.56	5.34	4.50	1.10
22	2.17	0.16	2.03	0.28	3.56	5.41	4.52	1.07
23	2.16	0.15	2.02	0.28	3.55	5.37	4.50	1.11
24	2.18	0.16	2.03	0.29	3.52	5.33	4.53	1.11
25	2.17	0.14	2.03	0.29	3.55	5.35	4.52	1.11
26	2.17	0.15	2.02	0.28	3.50	5.37	4.52	1.09
27	2.18	0.15	2.02	0.29	3.55	5.36	4.51	1.08
28	2.17	0.16	2.02	0.28	3.56	5.34	4.51	1.09
29	2.17	0.16	2.02	0.28	3.56	5.38	4.49	1.08
30	2.17	0.15	2.04	0.28	3.54	5.33	4.50	1.10
LSL	1.90	0.05	1.95	0.15	3.30	5.10	4.05	0.75
USL	2.45	0.20	2.20	0.40	3.95	5.60	4.60	1.50
MIN	2.11	0.14	2.01	0.27	3.47	5.33	4.49	1.06
MAX	2.18	0.17	2.05	0.29	3.56	5.41	4.55	1.12
AVG	2.17	0.16	2.02	0.28	3.52	5.36	4.52	1.09

6.3 Tests description

Test name	Description	Purpose
Die Oriented		
HTRB High Temperature Reverse Bias	The device is stressed in static configuration, trying to satisfy as much as possible the following conditions: <ul style="list-style-type: none"> - Low power dissipation - Max. supply voltage compatible with diffusion process and internal circuitry limitations. Forward: device is forward biased with a current fixed and adjusted to reach the targeted junction temperature	To determine the effects of bias conditions and temperature on solid state devices over time. It simulates the devices' operating condition in an accelerated way. To maximize the electrical field across either reverse-biased junctions or dielectric layers, in order to investigate the failure modes linked to mobile contamination, oxide ageing, layout sensitivity to surface effects. To assess active area and contacts integrity
Package Oriented		
PC Preconditioning	The device is submitted to a typical temperature profile used for surface mounting devices, after a controlled moisture absorption.	As stand-alone test: to investigate the moisture sensitivity level. As preconditioning before other reliability tests: to verify that the surface mounting stress does not impact on the subsequent reliability performance. The typical failure modes are "pop-corn" effect and delamination.
H3TRB High Humidity High Temperature Reverse Bias	The device is biased in static configuration minimizing its internal power dissipation, and stored at controlled conditions of ambient temperature and relative humidity.	To evaluate the package moisture resistance with electrical field applied, both electrolytic and galvanic corrosion are put in evidence.
TC Temperature Cycling	The device is submitted to cycled temperature excursions, between a hot and a cold chamber in air atmosphere.	To investigate failure modes related to the thermo-mechanical stress induced by the different thermal expansion of the materials interacting in the die-package system. Typical failure modes are linked to metal displacement, dielectric cracking, molding compound delamination, wire-bonds failure, die-attach layer degradation.
UHASt Unbiased Highly Accelerated Stress Test	The device is stored in saturated steam, at fixed and controlled conditions of pressure and temperature.	To investigate corrosion phenomena affecting die or package materials, related to chemical contamination and package hermeticity.
DPA Destructive Physical Analysis	Specific construction analysis on random parts that have successfully completed THB or TC.	To investigate on reliability stresses impact on delamination, corrosion and product construction integrity.
RSH Resistance to Solder Heat	Package is dipped by the leads in a solder bath after initial wet ageing (for SMDs only). Assessment by electrical test + no external crack	To simulate wave soldering process and verify that package will not be thermally damaged during this step.

Test name	Description	Purpose
DBT Dead Bug Test	To evaluate the wettability of the package leads. Good indicator to determine the bad solderability behavior	Components are glued up-side down on a substrate. Pins are wetted with a moderately activated flux. Then run once through the reflow oven with leadfree temperature profile. Visual inspection is performed with suitable tool.
SD Solderability	The purpose of this test method is to provide a referee condition for the evaluation of the solderability of terminations (including leads up to 0.125 inch in diameter) that will be assembled using tin lead eutectic solder.	This evaluation is based on the ability of these terminations to be wetted and to produce a suitable fillet when coated by tin lead eutectic solder. These procedures will test whether the packaging materials and processes used during the manufacturing operations process produce a component that can be successfully soldered to the next level assembly using tin lead eutectic solder. A preconditioning test is included in this test method, which degrades the termination finish to provide a guard band against marginal finish.
Functional Tests		
RS Repetitive Surges	The device is submitted to a reverse current peak: I_{pp} , which depends of the current holding of the product.	To evaluate the holding of the component to a high electrical field. Short circuit or hot point is expected as failure mechanism.



Public Products List

Public Products are off the shelf products. They are not dedicated to specific customers, they are available through ST Sales team, or Distributors, and visible on ST.com

PCN Title : Transfer of Assembly and Test line for TVS products housed in SMA & SMB packages

PCN Reference : POWER AND DISCRETE PRODUCTS/24/14700

Subject : Public Products List

Dear Customer,

Please find below the Standard Public Products List impacted by the change.

SMBJ16A-TR	SMBJ13CA-TR	SMAJ26CA-TR
SMAJ28A-TR	SMAJ18A-TR	SM6T30A
SMBJ22A-TR	SM6T22CA	SMBJ26A-TR
SMAJ15CA-TR	SMBJ12CA-TR	SM6T33CA
SMBJ15A-TR	SMAJ24CA-TR	SM6T22A
SMAJ13CA-TR	SMAJ18CA-TR	SMAJ26A-TR
SMBJ26CA-TR	SMBJ24A-TR	SM6T24CA
SMAJ33CA-TR	SMBJ36CA-TR	SMAJ28CA-TR
SMBJ22CA-TR	SMBJ30A-TR	SM6T39A
SM6T36CA	SMAJ48CA-TR	SM6T56CA
SMBJ12A-TR	SMAJ58CA-TR	SMAJ24A-TR
SMBJ24CA-TR	SM6T24A	SMAJ13A-TR
SM6T15A	SMBJ70CA-TR	SM6T68CA
SM6T27CA	SMAJ33A-TR	SMBJ18CA-TR
SMAJ12A-TR	SMBJ40CA-TR	SMBJ20A-TR
SM6T36A	SMBJ30CA-TR	SM6T27A
SM6T18CA	SMBJ48CA-TR	SMBJ28CA-TR
SMAJ43CA-TR	SMBJ20CA-TR	SM6T39CA
SMBJ58CA-TR	SM6T18A	SMAJ20A-TR
SMAJ15A-TR	SMAJ12CA-TR	SMAJ70CA-TR
SMAJ30A-TR	SM6T33A	SMBJ33A-TR
SMBJ15CA-TR	SM6T15CA	SMBJ33CA-TR
SMAJ30CA-TR	SMAJ40CA-TR	SMBJ18A-TR
SM6T30CA	SMBJ28A-TR	

IMPORTANT NOTICE – PLEASE READ CAREFULLY

Subject to any contractual arrangement in force with you or to any industry standard implemented by us, STMicroelectronics NV and its subsidiaries (“ST”) reserve the right to make changes, corrections, enhancements, modifications, and improvements to ST products and/or to this document at any time without notice. Purchasers should obtain the latest relevant information on ST products before placing orders. ST products are sold pursuant to ST’s terms and conditions of sale in place at the time of order acknowledgement.

Purchasers are solely responsible for the choice, selection, and use of ST products and ST assumes no liability for application assistance or the design of Purchasers’ products.

No license, express or implied, to any intellectual property right is granted by ST herein.

Resale of ST products with provisions different from the information set forth herein shall void any warranty granted by ST for such product.

ST and the ST logo are trademarks of ST. All other product or service names are the property of their respective owners.

Information in this document supersedes and replaces information previously supplied in any prior versions of this document.