

Application Note

Generator Interface Protection

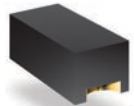

C650



CD1005



CG0402



CG0603

Generator manufacturers contend with a significant problem during installation that can result in a DOA (dead on arrival) equipment failure. The solution below describes a 'universal circuit protection' solution for low voltage generator interfaces.

BACKGROUND OF A TYPICAL GENERATOR INSTALLATION

The installation of a generator can be handled by a range of people from trained installers to your typical homeowner. The level of experience and skill required to install the generation equipment is not significant but small mistakes can cause damage that leaves the equipment inoperable. Because the installation handles both line voltage (120 VAC split phase, 240 V) and low voltage signals (less than 50 V), the opportunity for miswiring and resultant damage of equipment is quite easy and pronounced, creating a potential costly problem for the generator manufacturer. While manufacturers clearly mark and physically separate the terminals for each type of circuit, the installer can miswire the system by mixing high voltage with low voltage, quickly destroying sensitive circuits. A resettable overcurrent/overvoltage solution capable of handling line voltage and ESD/EFT/current surge is required to protect low voltage generator interface circuits against this problem.

Previously, a typical protection circuit would include a relay, resettable fuse and MOV combination to protect against the above combination of threats. The response of this circuit, number of components and space constraints demanded a new circuit design with a faster response and smaller footprint, etc. The ultimate goal for this circuit protection scheme was to create a 'universal circuit protection' solution that could be used at all exposed low voltage terminals of the generator and which could be deployed throughout the complete line of generators.

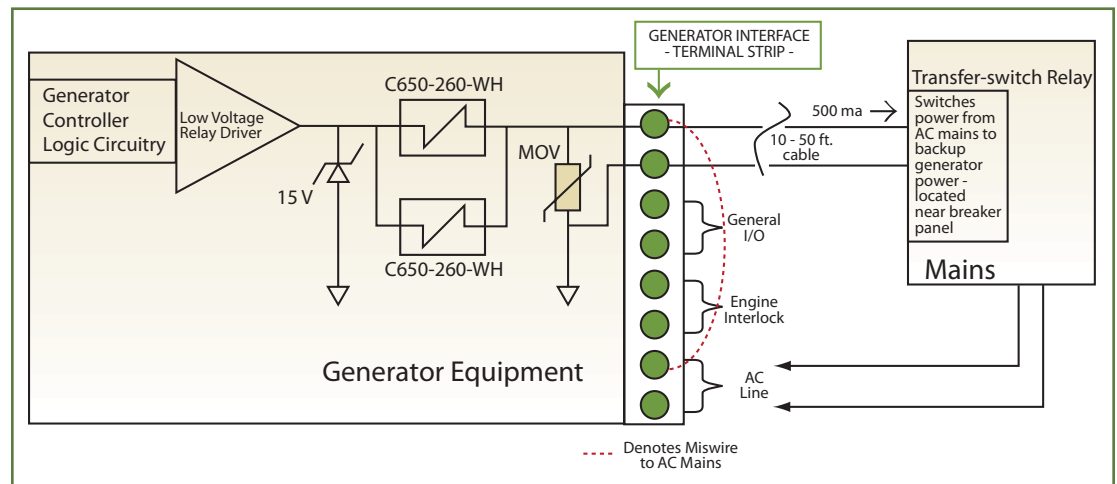

Generator Interface Protection Application Note



C650

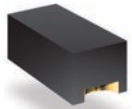

CD1005



CG0402



CG0603

DESCRIPTION OF CIRCUIT

The generator controller monitors the AC line voltage. Typically, a 10 second interruption of AC mains power turns on the low voltage relay driver circuit, energizing the transfer-switch relay. The transfer-switch relay is connected via a cable (typically 10 to 50 feet in length). This relay cable is exposed to inductive transients picked up from close proximity to the mains circuit panel wiring. During installation the length and position of the cable is indeterminate; the protection for this transient environment must be anticipated. Additionally, there are a number of terminals, again during installation, which can be miswired: 120 V split phase, neutral, engine interlock, relay I/O, etc.

This circuit protection solution handles the following threats:

- Power cross - mostly during installation from miswiring
- ESD - pre-installation from handling
- EFT - post installation from inductive load (relay) switching
- Current surge - post installation from load switching transients

Note:

The generator installation requires that a TVSS (Transient Voltage Surge Suppressor) module be installed at the breaker panel for adequate line surge suppression.

To provide protection against the above threats, a TBU™ device ('C' bidirectional series), MOV and zener diode have been used. The TBU™ device provides power cross and overcurrent protection. The zener diode provides low voltage clamping to protect sensitive circuits and to create an avalanche current, which triggers the TBU™ device. The MOV was selected to protect the TBU™ device from seeing excessive common mode voltages when exposed to ESD and EFT. The MOV voltage was chosen to be 360 V, to allow the line-to-line peak voltage ($120 V_{\text{rms}} * 2 * 1.414 = 340 \text{ VAC}$) to pass unclamped. Voltages in excess of the peak-to-peak line voltage will be clamped to stay within the 650 V maximum common mode voltage of the TBU™ device. The TBU™ devices are used in parallel to provide the 500 ma (260 ma X 2) current drive requirement of the transfer-switch relay, demonstrating the scalability of the TBU™ product line.

For further technical support and for complete circuit protection solutions, please visit www.bourns.com

COPYRIGHT © 2010 • BOURNS, INC. • XX/10 • FU0954

"TBU" is a trademark of Bourns, Inc.

"Multifuse" and "Bourns" are registered trademarks of Bourns, Inc. in the U.S. and other countries.