



Designing the VCNL4200 Into an Application

By Reinhard Schaar

INTRODUCTION AND BASIC OPERATION

The VCNL4200 is a fully integrated proximity and ambient light sensor. It combines an infrared emitter and photodiode for proximity measurement, ambient light sensor (ALS), and signal processing IC in a single package with a 16-bit ADC for ALS and a 12-bit / 16-bit ADC for proximity ADC. The device provides ambient light sensing to support conventional backlight and display brightness auto-adjustment, and proximity sensing to recognize objects up to a distance of 1.5 m (60").

This stand-alone component greatly simplifies the use and design-in of a proximity sensor (PS) in consumer and industrial applications, because the embedded IRED and photodiode are exactly matched to each other. The VCNL4200 features a miniature, surface-mount 8.0 mm by 3.0 mm leadless package (LLP) with a height of 1.8 mm. The device is designed specifically to meet the requirements for applications where objects need to be identified at far distances.

Through its standard I²C bus serial digital interface, the VCNL4200 allows easy access to "proximity signal" and "light intensity" measurements. The programmable interrupt function offers wake-up functionality for the microcontroller when a proximity event or ambient light change occurs, which reduces processing overhead by eliminating the need for continuous polling.



Fig. 1 - VCNL4200 Top View

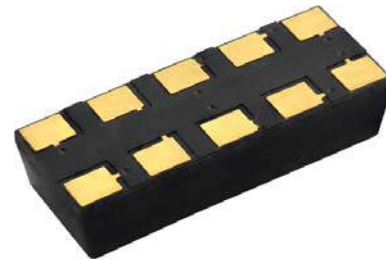

Fig. 2 - VCNL4200 Bottom View

COMPONENTS (BLOCK DIAGRAM)

The major components of the VCNL4200 are shown in the block diagram.

In addition to the ASIC with the ambient light and proximity photodiode, the infrared emitter is also implemented. Its cathode needs to be connected to the driver externally (see Fig. 6).

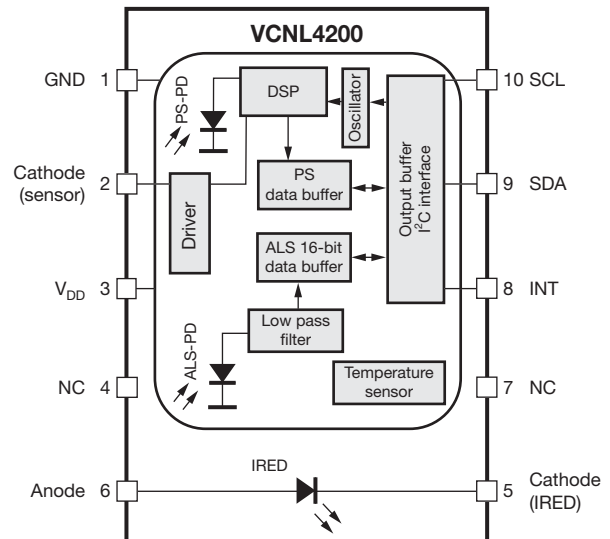

Fig. 3 - VCNL4200 Detailed Block Diagram

The integrated infrared emitter has a peak wavelength of 940 nm. It emits light that reflects off an object within 100 cm of the sensor. Two added lenses help to increase peak intensity and sensitivity by enabling a small angle of just ± 15° for the emitter and ± 30° for the detector, as shown in Fig. 4 and Fig. 5.

APPLICATION NOTE

Designing the VCNL4200 Into an Application

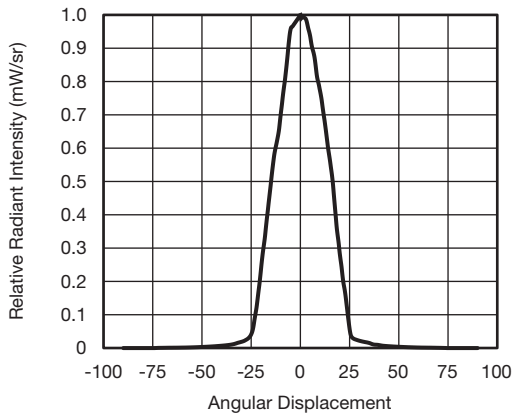

Fig. 4 - Relative Radiant Intensity vs. Angular Displacement (Cartesian view)

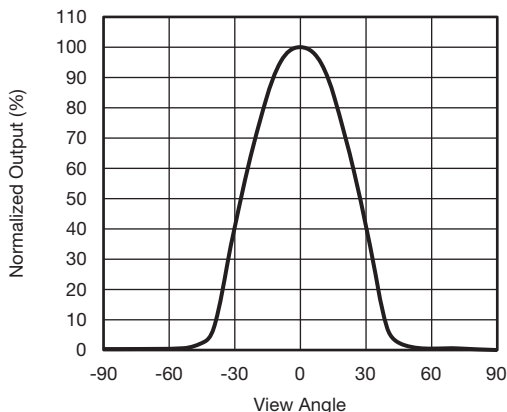

Fig. 5 - ALS Normalized Output vs. View Angle

The ASIC delivers a current that is already within 50 mA of being high enough to drive a small external FET. A series resistor added to the IRED defines the wanted pulse current, as shown in Fig. 18. The infrared light is emitted in short pulses with a programmable duty ratio from 1/160 to 1/1280. The proximity photodiode receives the light that is reflected off the object and converts it to a current. It has a peak sensitivity of 940 nm, matching the peak wavelength of the emitter. The sensitivity of the proximity stage is also programmable by choosing from four different integration times. It is insensitive to ambient light. It ignores the DC component of light and “looks for” the pulsed light at the proximity frequency used by the emitter.

The ambient light sensor receives the visible light and converts it to a current. The human eye can see light with wavelengths from 400 nm to 700 nm, with a peak of 560 nm. Vishay’s ambient light sensor closely matches this range of sensitivity. It has peak sensitivity at 540 nm and a bandwidth from 430 nm to 610 nm.

The application-specific integrated circuit, or ASIC, includes an LED driver, I²C bus interface, amplifier, integrated analog to digital converter, oscillator, and Vishay’s “secret sauce” signal processor. For proximity, it converts the current from the photodiode to an 12-bit / 16-bit digital data output value. For ambient light sensing, it converts the current from the ambient light detector, amplifies it, and converts it to a 16-bit digital output stream.

PIN CONNECTIONS

Fig. 3 shows the pin assignments of the VCNL4200.

The connections include:

- Pin 1 - connect to ground
- Pin 2 - IR cathode (sensor side)
- Pin 3 - V_{DD} to the power supply
- Pin 4 - no connection
- Pin 5 - IRED cathode (IRED side)
- Pin 6 - IRED anode to the power supply resp. FET
- Pin 7 - no connection
- Pin 8 - INT to microcontroller
- Pin 9 - SDA to microcontroller
- Pin 10 - SCL to microcontroller

The power supply for the ASIC (V_{DD}) has a defined range from 2.5 V to 3.6 V. It is best if the V_{DD} is connected to a regulated power supply and pin 6, the anode of the built-in IRED, is connected - via a small FET - directly to the battery. This eliminates any influence of the high infrared emitter current pulses on the V_{DD} supply line.

If separate power supplies for the V_{DD} and the infrared emitter are used, and there are no negative spikes below 2.5 V, a small 100 nF capacitor should be placed close to the V_{DD} pin and a 2.2 μF capacitor at the source of the external driver FET. This is sufficient at the supply voltage for the IRED, which needs to be between 3.3 V and 5 V. In addition, a 5 kΩ pull-up resistor is needed at the gate. At the cathode of the IRED (pin 5), a current-defining resistor is needed. This could be as low as 2.7 Ω, which would then lead to about 800 mA. The SCL and SDA, as well as the interrupt lines, need pull-up resistors. The resistor values depend on the application and on the I²C bus speed. Common values are about 2.2 kΩ to 4.7 kΩ for the SDA and SCL, and about 8.2 kΩ to 22 kΩ for the interrupt line.

Designing the VCNL4200 Into an Application

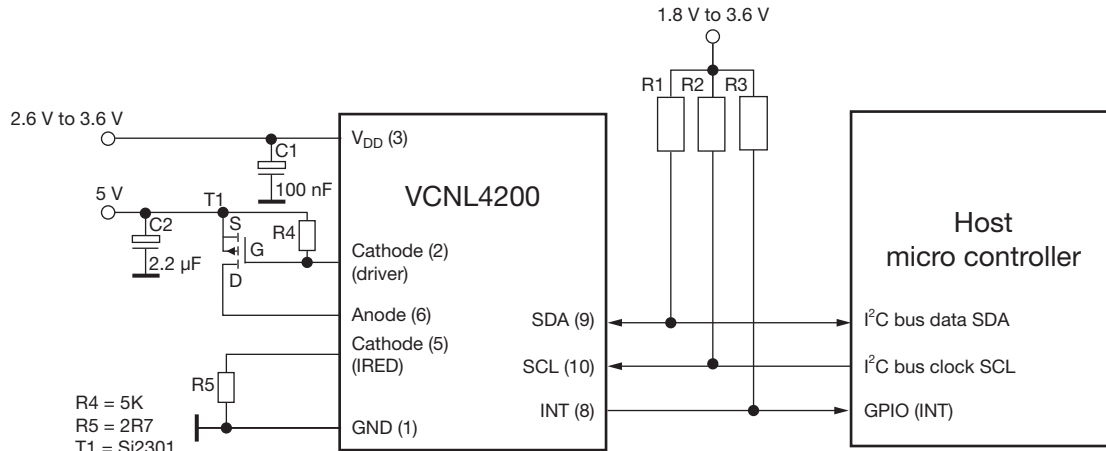

Fig. 6 - VCNL4200 Application Circuit

MECHANICAL DESIGN CONSIDERATIONS

The VCNL4200 is a fully integrated proximity and ambient light sensor. Competing sensors use a discrete infrared emitter, which leads to complex geometrical calculations to determine the position of the emitter.

With the VCNL4200, the only dimensions that the design engineer needs to consider are the distance from the top surface of the sensor to the outside surface of the window, and the size of the window. These dimensions will determine the size of the detection zone.

The angle of half intensity of the emitter is about $\pm 15^\circ$, as shown in Fig. 7, and the sensitivity of the photodiodes is about $\pm 30^\circ$.

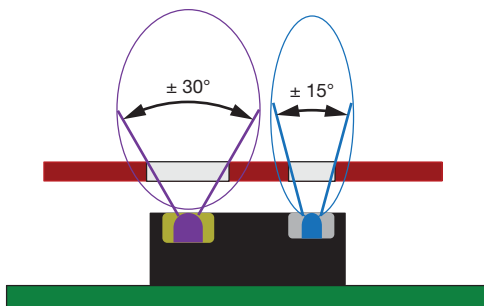

Fig. 7 - Emitter and Detector Angle

To achieve a good ambient light response, the diameter of the detector hole within the cover glass should not be too small. An angle of $\pm 30^\circ$ will be sufficient in most applications. The package drawing shows the position of the IRED and photosensitive area. The $+30^\circ$ line should be set at the side of the photodiode, towards pin 1. The -30° line should be set no closer than 1 mm to that edge. Please also note from Fig. 5 that the viewing angle of the ALS is very small, so accurate values will only be measured if the light source is directly above the sensor. The following are dimensions for the distance from the top surface of the sensor to the outside surface of the glass, a , and the width of the window, d .

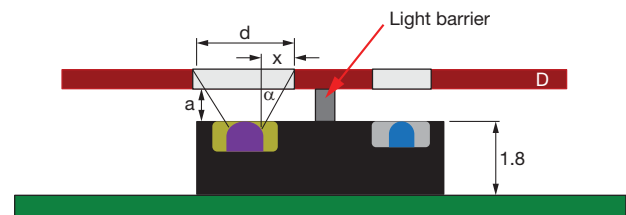

Fig. 8 - Window Diameter for Detector Hole

For the detector hole, a diameter of ≥ 2 mm would be needed.

Designing the VCNL4200 Into an Application

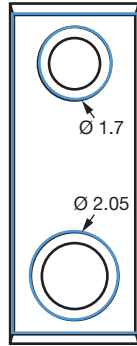

Fig. 9 - Light Hole Diameters

The diameter needs to be increased with distances between the sensor and cover glass according to the following calculation.

For the detector hole, the width calculation for distances from 0 mm to 3 mm results in:

$a = 0.0 \text{ mm} \rightarrow x = 0.0 \rightarrow d = 2.0 \text{ mm} + 0.00 = 2.00 \text{ mm}$
 $a = 0.5 \text{ mm} \rightarrow x = 0.29 \rightarrow d = 2.0 \text{ mm} + 0.58 = 2.58 \text{ mm}$
 $a = 1.0 \text{ mm} \rightarrow x = 0.58 \rightarrow d = 2.0 \text{ mm} + 1.16 = 3.16 \text{ mm}$
 $a = 1.5 \text{ mm} \rightarrow x = 0.87 \rightarrow d = 2.0 \text{ mm} + 1.74 = 3.74 \text{ mm}$
 $a = 2.0 \text{ mm} \rightarrow x = 1.16 \rightarrow d = 2.0 \text{ mm} + 2.32 = 4.32 \text{ mm}$
 $a = 2.5 \text{ mm} \rightarrow x = 1.45 \rightarrow d = 2.0 \text{ mm} + 2.90 = 4.90 \text{ mm}$
 $a = 3.0 \text{ mm} \rightarrow x = 1.74 \rightarrow d = 2.0 \text{ mm} + 3.48 = 5.48 \text{ mm}$

For the smaller IRED hole, the diameter can be as small as 1.7 mm.

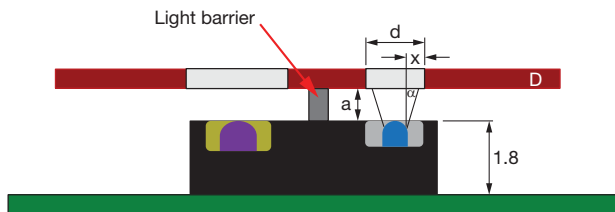

Fig. 10 - Window Diameters for IRED Hole

The width calculation for distances from 0 mm to 3 mm results in:

$a = 0.0 \text{ mm} \rightarrow x = 0.00 \rightarrow d = 1.7 \text{ mm} + 0.0 = 1.7 \text{ mm}$
 $a = 0.5 \text{ mm} \rightarrow x = 0.15 \rightarrow d = 1.7 \text{ mm} + 0.3 = 2.0 \text{ mm}$
 $a = 1.0 \text{ mm} \rightarrow x = 0.30 \rightarrow d = 1.7 \text{ mm} + 0.6 = 2.3 \text{ mm}$
 $a = 1.5 \text{ mm} \rightarrow x = 0.45 \rightarrow d = 1.7 \text{ mm} + 0.9 = 2.6 \text{ mm}$
 $a = 2.0 \text{ mm} \rightarrow x = 0.60 \rightarrow d = 1.7 \text{ mm} + 1.2 = 2.9 \text{ mm}$
 $a = 2.5 \text{ mm} \rightarrow x = 0.75 \rightarrow d = 1.7 \text{ mm} + 1.5 = 3.2 \text{ mm}$
 $a = 3.0 \text{ mm} \rightarrow x = 0.90 \rightarrow d = 1.7 \text{ mm} + 1.8 = 3.5 \text{ mm}$

The mechanical design also needs the placement of a light barrier in between the IRED and detector to avoid any crosstalk.

PROXIMITY SENSOR

The main DC light sources found in the environment are sunlight and tungsten (incandescent) bulbs. These kinds of disturbance sources will cause a DC current in the detector inside the sensor, which in turn will produce noise in the receiver circuit. The negative influence of this DC light can be reduced by optical filtering, but is reduced much more efficiently by a so-called DC kill function. The proximity photodiode shows its best sensitivity at about 940 nm, as shown in Fig. 11.

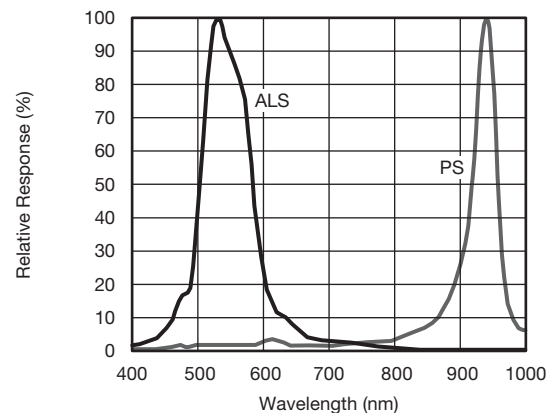

Fig. 11 - Spectral Sensitivity of ALS and Proximity Photodiode

The proximity sensor uses a short pulse signal of about 30 μs (PS_IT = 1T) up to 240 μs (PS_IT = 9T). The on / off duty ratio setting now defines which repetition rate to be used, which can be programmed from 1/160 up to 1/1280.

In addition to DC light source noise, there is some reflection of the infrared emitted light off the surfaces of the components surrounding the VCNL4200. The distance to the cover, proximity of surrounding components, tolerances of the sensor, ambient temperature, and type of window material used all contribute to this reflection. The result of the reflection and DC noise is the production of an output current on the proximity and light-sensing photodiode. This current is converted into a count called the offset count.

In addition to the offset count, there could also be a small noise floor during the proximity measurement, which comes from the DC light suppression circuitry. This noise is typically just one or two counts. Only with light sources with strong infrared content could it be in the range from ± 5 counts to ± 10 counts.

The application should “ignore” this offset and small noise floor by subtracting them from the total proximity readings.

Results most often do not need to be averaged. If an object with very low reflectivity or at longer range needs to be detected, the sensor provides a register where the customer can define the number of consecutive measurements that the signal must exceed before producing an interrupt. This provides stable results without requiring averaging.

Designing the VCNL4200 Into an Application

PROXIMITY CURRENT CONSUMPTION

Both the ambient light sensor and the proximity sensor within the VCNL4200 offer a separate shutdown mode. Default values after start-up have them both disabled. The application either or both as needed.

The VCNL4200's embedded LED driver drives the internal IRED via the "LED CATHODE" pin with a pulsed duty cycle. With the given application circuit in Fig. 6., the current with which the LED is driven depends on the series resistor R5. The value chosen for the resistor depends on the I_F vs. V_F characteristics as shown in Fig. 12.

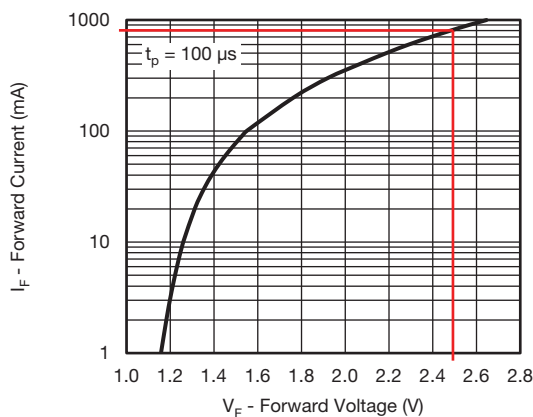

Fig. 12 - Forward Current vs. Forward Voltage

If an 800 mA drive current is to be used, the typical forward voltage (V_F) is 2.5 V, as shown on the graph. Taking into account its internal $R_{DS(on)}$, there will be an additional 0.2 V to 0.3 V voltage drop across the FET. At a V_{DD} of 5 V this leaves a 2.2 V drop across R5.

$$R = V/I = 2.2 \text{ V}/0.8 \text{ A} = 2.7 \Omega$$

The IRED on / off duty ratio is programmable by an I²C command at register PS_Duty. Depending on this pulse / pause ratio, the overall proximity current consumption can be calculated. When a higher measurement speed or faster response time is needed, PS_Duty may be selected to a maximum value of 1/160, which means one measurement will be made every 5 ms, but this will then also lead to the highest current consumption:

PS_Duty = 1/160: peak IRED current = 800 mA,
average current consumption is 800 mA/160 = 5.3 mA.

For proximity measurements executed every 300 ms only:
PS_Duty = 1/1280 peak IRED current = 800 mA,
average current consumption is 800 mA/1280 = 0.67 mA.

The above is always valid for the normal pulse width of $T = 1T = 32 \mu\text{s}$, as well as for 2T, 4T, 8T, and 9T. These pulse lengths are widened according to the factor, resulting in 240 μs for 9T, but the repetition time is also extended, ending in a period time of about 300 ms.

Besides PS_IT, there is also the possibility for "multi-pulsing", PS_MPS.

Instead of one single pulse per every defined time frame, one can program 2, 4, or even 8 pulses. This leads to a longer IRED on-time for each proximity measurement, which also results in a higher detection range.

But these eight pulses instead of just one could already be long enough that the possible IRED current needs to be reduced. The reduction is now also dependent on the duty ratio. This duty ratio stays identical, whether it is just one or up to eight pulses that are programmed.

With PS_IT = 9T, which leads to about 240 μs single pulses, the pulses will occur quickly after each other eight times (please see scope screenshots below).

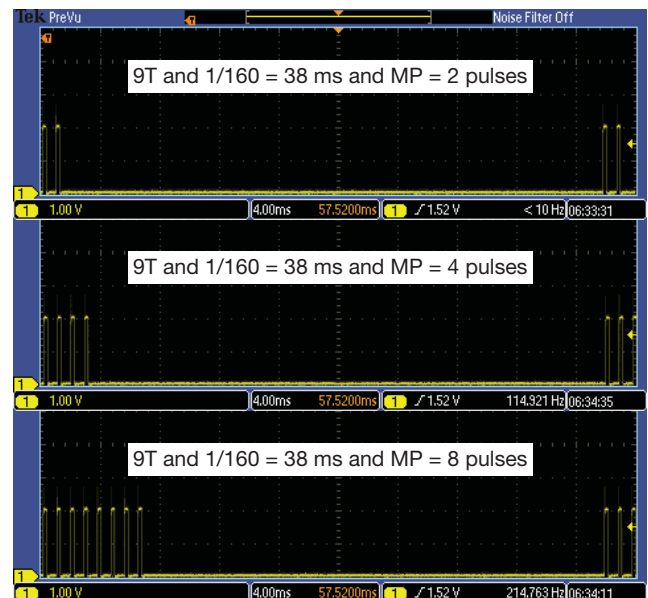

Fig. 13 - Proximity Measurements
With PS_Duty = 1/160, PS_IT = 9T, and MP

For PS_MPS = 8 pulses, the total IRED on-time within one time frame is then 8 x 240 μs ; so, about 2 ms. The total off-time between two MPS proximity measurements is then not 38 ms, but 38 ms - 7 x 0.24 ms = 38 ms - 1.7 ms = 36 ms.

With this the ratio $t_p/T = 2 \text{ ms}/36 \text{ ms} = 0.055$.

So, one needs to reduce the IRED current here to about 500 mA (see Fig. 14 below), or the repetition rate needs to be set to lower values, such as 1/160.

Designing the VCNL4200 Into an Application

For a duty cycle of 1/640, these pulse bursts will occur every 150 ms; so, about seven measurements per second and the pulse-pause ratio will go down to 2 ms/150 ms = 0.013. With this, 600 mA will be possible.

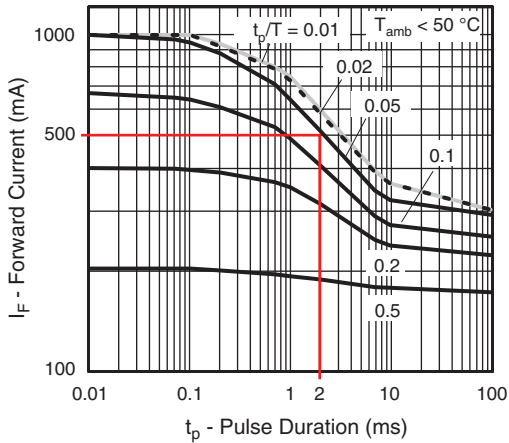

Fig. 14 - Pulse Forward Current vs. Pulse Duration

INITIALIZATION AND I²C TIMINGS

The VCNL4200 contains nine 16-bit command codes for operation control, parameter set up, and result buffering. All registers are accessible via I²C communication. The built-in I²C interface is compatible with the standard and high speed I²C modes. The I²C H-level voltage range is from 2.5 V to 3.6 V.

There are only three registers out of the eight that typically need to be defined:

1. PS_Duty = 1/160 to 1/1280 (proximity duty ratio), PS_IT (proximity integration time = pulse length), PS_PERS (number of consecutive measurements above / below threshold), and PS_SD (PS power_on)
2. ALS_IT (ALS integration time) ALS_PERS (number of consecutive measurements above / below threshold), and ALS_SD (ALS power_on)
REGISTER ALS_CONF #00 [0x00h]
3. Definition of the threshold value from the number of counts the detection of an object should be signaled:
Proximity TOP Threshold REGISTER, PS_THDL_L in lower byte for #06, and PS_THDL_H in upper byte of #06

To define the infrared emitter current, as well as the integration time (length of the proximity pulsing), evaluation tests should be performed using the least reflective material at the maximum distance specified.

Fig. 15 shows the typical digital counts output versus distance for an integration time of 9T, but without multi-pulsing. The reflective reference medium is the Kodak

Gray card. This card shows approximately 18 % reflectivity at 940 nm.

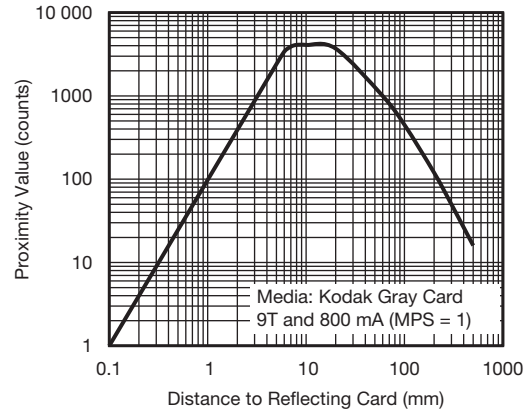

Fig. 15 - Proximity Value vs. Distance for PS_IT= 9T and I_{IRED} = 800 mA

The above diagram shows the possible detection counts with a pulse of 240 μs.

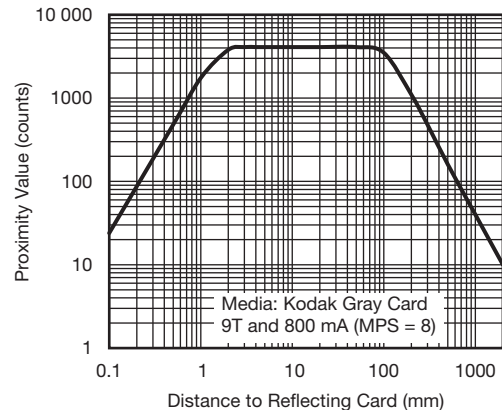

Fig. 16 - Proximity Value vs. Distance for PS_IT = 9T, MPS = 8 pulses and I_{IRED} = 800 mA

Applying eight multi-pulses with each 240 μs will surely lead to saturation for low distances of an object, especially for white cards.

Designing the VCNL4200 Into an Application

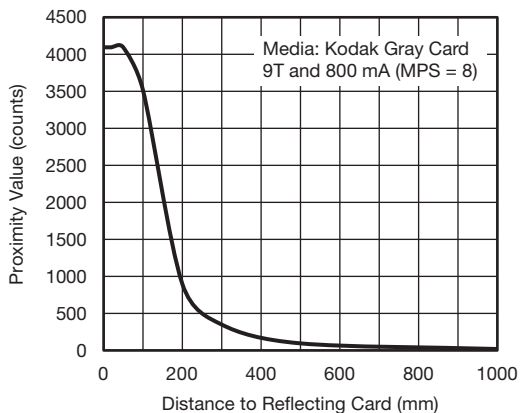

Fig. 17 - Proximity Value vs. Distance (axis with linear values)

Presenting the graph above in linear view shows data values between 20 cm and 1 m.

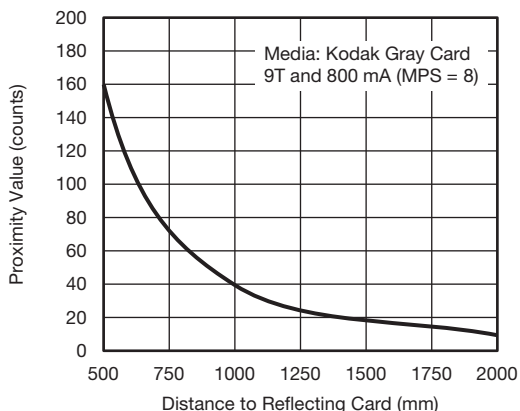

Fig. 18 - Proximity Counts vs. Distance Just for > 50 cm Distance

Reducing this graph to just more than 0.5 m shows about 20 counts at a distance of 1.5 m, even for the Kodak Gray card.

With defining the duty time (PS_Duty), the repetition rate = the number of proximity measurements per second (speed of proximity measurements) is defined. This is possible between 5 ms (more than 100 measurements/s) by programming PS_Duty with 1/160 and 34 ms (about 30 measurements/s) with programming PS_Duty with 1/1280. It ends up at about 300 ms duty time when programmed to the longest possible pulse of 0.24 ms (PS_IT = 9T).

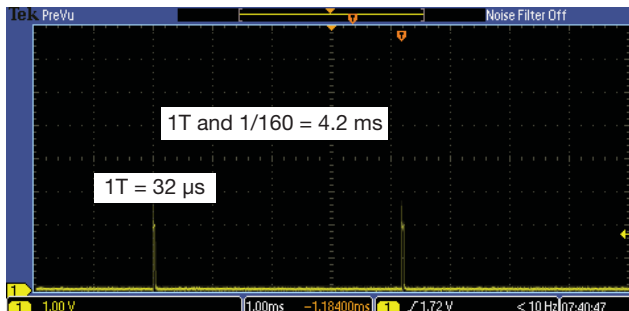

Fig. 19 - Proximity Measurements With PS_Duty = 1/160 and PS_IT = 1T

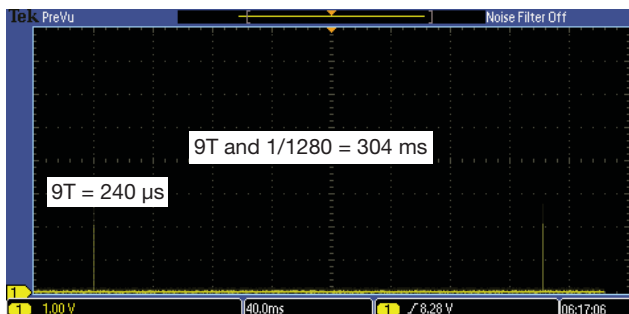

Fig. 20 - Proximity Measurements With PS_Duty = 1/1280 and PS_IT = 9T

This duty cycle also determines how fast the application reacts when an object appears in, or is removed from, the proximity zone.

Reaction time is also determined by the number of counts that must be exceeded before an interrupt is set. This is possible to define with proximity persist: PS_PERS. Possible values are from 1 to 4.

To define all these register values, an evaluation test should be performed. The sensor starter kit allows you to perform evaluation tests and properly set the registers for your application. The kit is available from any of Vishay's distributors. It comes with the VCNL4020 sensor board. The VCNL4200 sensor board can be requested by sending an e-mail to sensorstechsupport@vishay.com.

Designing the VCNL4200 Into an Application

Timing

For an I²C bus operating at 100 kHz, to write or read an 8-bit byte, plus start (or stop) and bit acknowledgement, takes 100 μs. Together with the slave address byte and the 8-bit command code byte, plus the 16-bit data, this results in a total of 400 μs. When the device is powered on, the initialization with just these five registers needs 5 x 4 bytes (slave address, command register, and 16-bit data) for a total of 20 bytes. So, 20 x 100 μs = 2000 μs = 2 ms.

Send Byte → Write Command to VCNL4200



The read-out of 16-bit data would take a total of five bytes (slave address, command code, slave address with read bit set) and 16-bit data sent from the VCNL4200. So, 500 μs:

Receive Byte → Read Data from VCNL4200

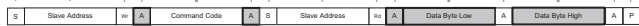

Power Up

The release of the internal reset, the start of the oscillator, and the signal processor need **2.5 ms**

Initialize Registers

Write to three registers **1200 μs**

- Proximity duty ratio
- ALS integration time
- Proximity interrupt TOP threshold

After programming command code 06 with the evaluated threshold values, command code 04 with the provided and proposed values, and command code 00 with the needed ALS integration time, the command code 03 will power up the sensor with the needed proximity pulse and in the wanted duty cycle.

Asking for one forced proximity measurement **400 μs**

For (active forced, PS_IT = 2)

Time to trigger [0.5 x PS_IT] **500 μs**

DC-kill ambient light [3 x PS_IT] **3000 μs**

Proximity measurement [1 x PS_IT] **1000 μs**

IRED shutdown [1 x PS_IT] **1000 μs**

Read out of the proximity data **500 μs**

total: **6400 μs**

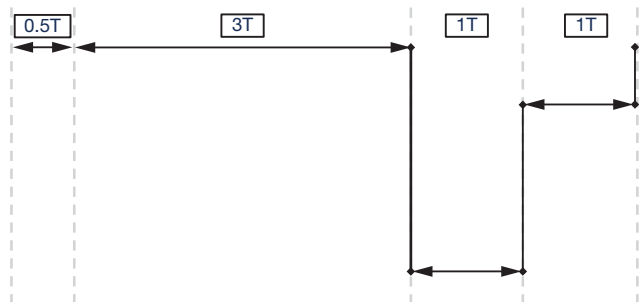

Fig. 21 - Timing Specification for Active Forced Mode

AMBIENT LIGHT SENSING

Ambient light sensors are used to detect light or brightness in a manner similar to the human eye. They allow settings to be adjusted automatically in response to changing ambient light conditions. By turning on, turning off, or adjusting features, ambient light sensors can conserve battery power or provide extra safety by eliminating the need for manual adjustments.

Illuminance is the measure of the intensity of a light incident on a surface and can be correlated to the brightness perceived by the human eye. In the visible range, it is measured in units called “lux.” Light sources with the same lux measurement appear to be equally bright. In Fig. 20, the incandescent light and sunlight have been scaled to have the same lux measurement.

In the infrared region, the intensity of the incandescent light is significantly higher. A standard silicon photodiode is much more sensitive to infrared light than visible light. Using it to measure ambient light will result in serious deviations between the lux measurements of different light sources and human eye perception. Using Vishay’s ambient light sensors will solve this problem because they are most sensitive to the visible part of the spectrum.

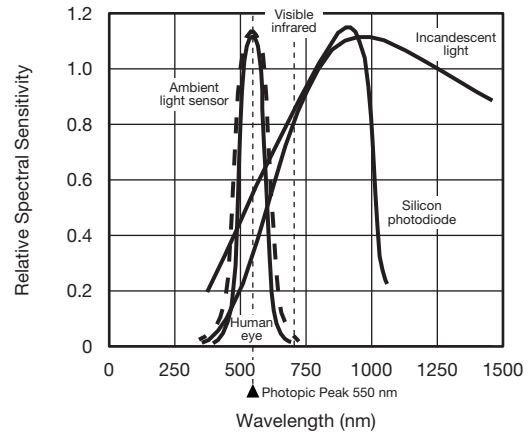

Fig. 22 - Relative Spectral Sensitivity vs. Wavelength

The human eye can see light with wavelengths from 400 nm to approximately 700 nm. The ambient light sensor array in the VCNL4200 closely matches this range of sensitivity and provides a digital output based on a 16-bit signal.



Designing the VCNL4200 Into an Application

AMBIENT LIGHT MEASUREMENT, RESOLUTION, AND CALCULATION

The ambient light sensor’s measurement resolution is defined to about 0.003 lux/count for the highest sensitivity with a 640 ms integration time. The 16-bit digital resolution is equivalent to 65 536 counts. This yields a measurement range from 0.003 lux to 1311 lux. For higher illuminance, a shorter integration time needs to be selected, which results in lower resolution.

ALS RESOLUTION AND MAXIMUM DETECTION RANGE			
ALS_IT		SENSITIVITY (lx/step)	MAXIMUM DETECTION RANGE (lx)
ALS_IT (7 : 6)	INTEGRATION TIME		
(0, 0)	50 ms	0.024	1573
(0, 1)	100 ms	0.012	786
(1, 0)	200 ms	0.006	393
(1, 1)	400 ms	0.003	197

AMBIENT LIGHT SENSOR CURRENT CONSUMPTION

The ambient light sensor can operate with four selectable integration times from 80 ms to 640 ms.

During ALS measurements, the device consumes approximately 213 µA.

AMBIENT LIGHT INITIALIZATION AND I²C INTERFACE

For ambient light sensing, only the low byte of command code #0 needs to be initialized:

- ALS_SD (bit 0 = 0 = ALS Power_on)
- ALS_INT_EN (bit 1 = 1 = ALS interrupt enable)
- ALS_PERS (bit 2, 3: no. of interrupt persistence)
- ALS_IT (bit 6, 7: integration time)

The rate for self-timed measurements is dependent on the integration time.

For unknown brightness conditions, it should always be started with the shortest integration time. This avoids possible overload / saturation. Only if ambient light result register values are very low, e.g. no content within the high byte of the 16-bit register (#9), should the next more sensitive integration time be used.

Calculating the available lux level is done by multiplying the ambient light result value from register 9 (L and H byte) with the integration time / resolution.

Example: integration time is at 100 ms and 0x09H and 0x09L show 01010100 and 01110110, expressed in decimals: 21 622 counts leading to 21 622 x 0.012 to 259 lx.

Within the ready-made application, this factor should be fine-tuned, as cover glass and the size of the opening will also impact the result.

Interrupt

The VCNL4200 features a very intelligent interrupt function. The interrupt function enables the sensor to work independently until a predefined proximity or ambient light event or threshold occurs. It then sets an interrupt which requires the microcontroller to awaken. This helps customers reduce their software effort, and reduces power consumption by eliminating polling communication traffic between the sensor and microcontroller.

The interrupt pin, pin 8, of the VCNL4200 should be connected to a dedicated GPIO of the controller. A pull-up resistor is added to the same power supply that the controller is connected to. This INT pull-up resistor may be in the range of 8.2 kΩ to 100 kΩ.

The events that can generate an interrupt include:

1. A lower and an upper threshold for the proximity value can be defined. If the proximity value falls below the lower limit or exceeds the upper limit, an interrupt event will be generated. In this case, an interrupt flag bit in the read-out register 0x0B will be set and the interrupt pad of the VCNL will be pulled to low by an open drain pull-down circuit. In order to eliminate false triggering of the interrupt by noise or disturbances, it is possible to define the number of consecutive measurements that have to occur before the interrupt is triggered
2. A lower and an upper threshold for the ambient light value can be defined. If the ambient light value falls below the lower limit or exceeds the upper limit, an interrupt event will be generated. There are two sets of high and low threshold registers, so both thresholds for proximity and ambient light can be observed in parallel

Besides this “normal” interrupt mode, an automatic mode is also available, which is called the logic output mode.

This mode automatically pulls the interrupt pin low when an object exceeds the programmed upper threshold and also resets it if the lower threshold is exceeded. So no actions from the controller are needed if, for example, a smartphone is held close to an ear but is quickly taken away (e.g. for a short look at the display).

Application Example

The following example will demonstrate the ease of using the VCNL4200 sensor. Customers are strongly encouraged to purchase a sensor starter kit and request a VCNL4200 sensor board from sensorstechsupport@vishay.com.

Designing the VCNL4200 Into an Application

Offset

During development, the application-specific offset counts for the sensor were determined. As previously mentioned, the offset count is affected by the components surrounding the VCNL4200, the window or cover being used, the distance from the sensor to the cover, and emitter intensity, defined by the forward current, which is dependent on the value of the series resistor used.

In the following example, with a cover over the sensor and choosing a 2.7 Ω series resistor, about 800 mA peak current flows through the sensor's internal IRED and the offset counts are seven counts (Fig. 23). Offset counts vary by application and can be anywhere from 0 counts to several tens of counts. It is important to note that the offset count may change slightly over time due to, for example, the window becoming scratched or dirty, or being exposed to high temperature changes. If possible, the offset value should occasionally be checked and, if necessary, modified.

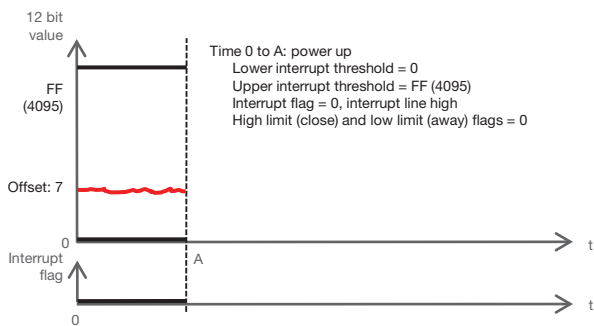

Fig. 23

Power Up

As mentioned, there are three variables for proximity measurement that need to be set in the register when the sensor is powered up: the number of occurrences that must exceed a threshold to generate an interrupt, the threshold values, and the number of proximity measurements per second.

The sensor should detect persons at a distance of 100 cm. Development testing determined that a current of 800 mA produces adequate counts for detection. The proximity measurement rate is set so that about 10 measurements are done within a second and the number of occurrences to trigger an interrupt is set to four. Based on development testing, with a person wearing quite dark clothes at about a 100 cm distance, the resulting total count is 10. This will be used as the upper threshold (high threshold).

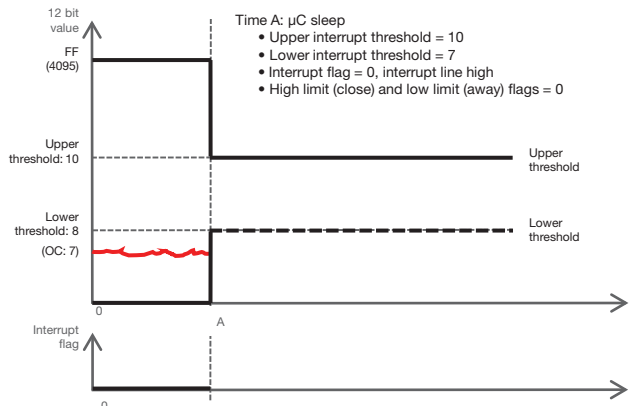

Fig. 24

By setting the number of occurrences before generating an interrupt to four, a single proximity value above or below the thresholds will have no effect, as shown in Fig. 25.

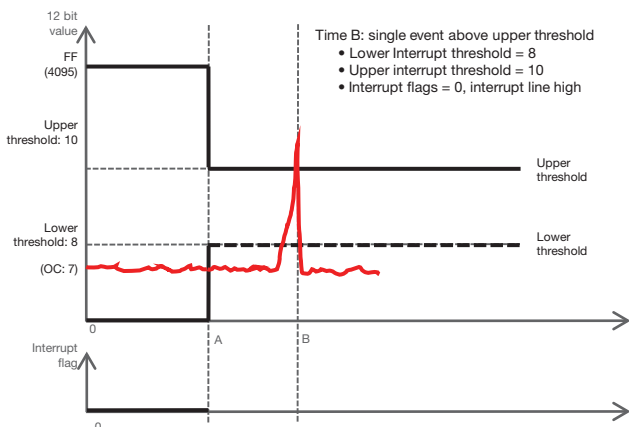

Fig. 25

Home appliance applications such as intelligent coffee machines and ovens and others will wake up when a person comes close and turns on their display. For other applications, such as automatic dispensing, the soap or towel will be dispensed.

Designing the VCNL4200 Into an Application

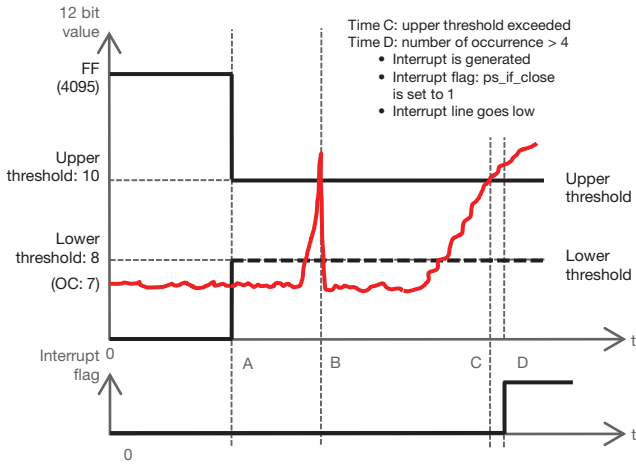

Fig. 26

In some applications, the bottom threshold will also be programmed and wait for an interrupt signal. The ps_if_away is also set to “1” and the ps_if_close cleared by reading it, since the object is close to the sensor. A lower threshold will occur when the object (person) is no longer that close before the sensor and the display and / or light will no longer be illuminated.

For this example, the lower threshold is also set to a defined level, here just eight counts, which is just one count more than the typical offset count.

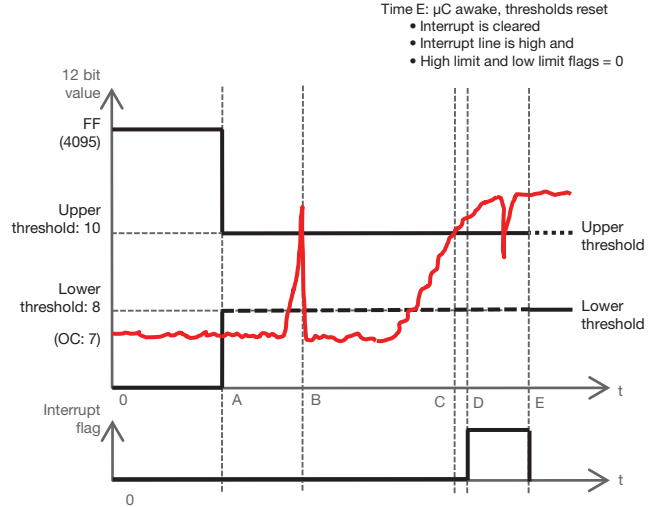

Fig. 27

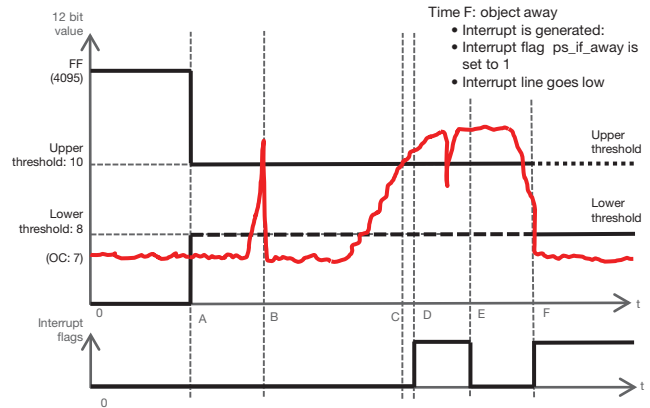

Fig. 28

Designing the VCNL4200 Into an Application

Some measurements and features are shown with the demo tool and demo software with a cover glass at about a 1 mm distance.

1. Proximity set-up with 9T wide pulses, 800 mA emitter current, and a duty cycle of 1/640, which results in about six measurements per second (MPS = 1).

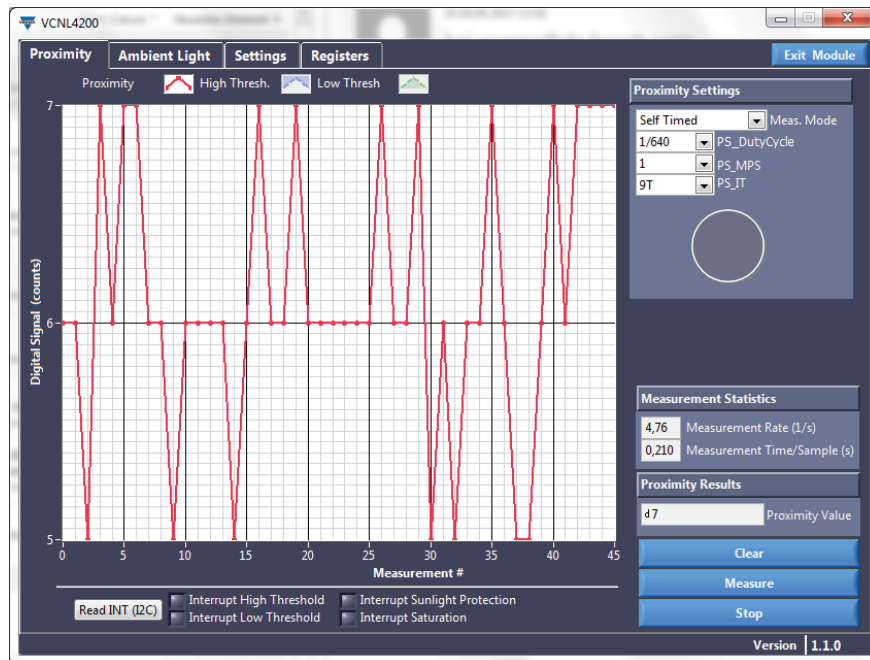

Fig. 29

2. If a hand or skin now comes as close as 50 cm, these seven counts rise up to more than 10 counts.

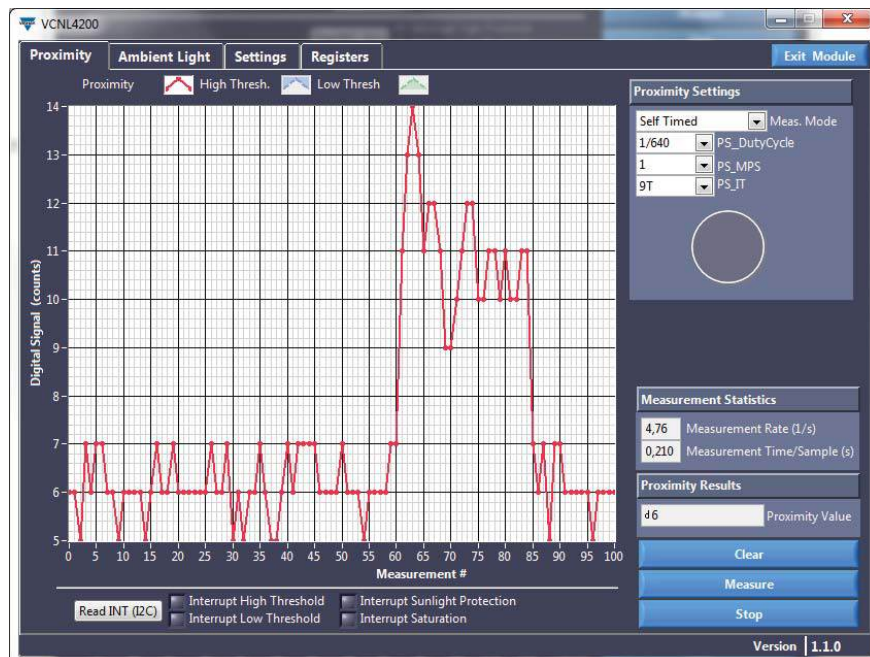

Fig. 30

Designing the VCNL4200 Into an Application

3. Here the thresholds are programmed as 10 for the upper and eight for the lower. To see these, both “Show” buttons are activated. The presence of an object should only be recognized when four consecutive measurements are above that threshold.

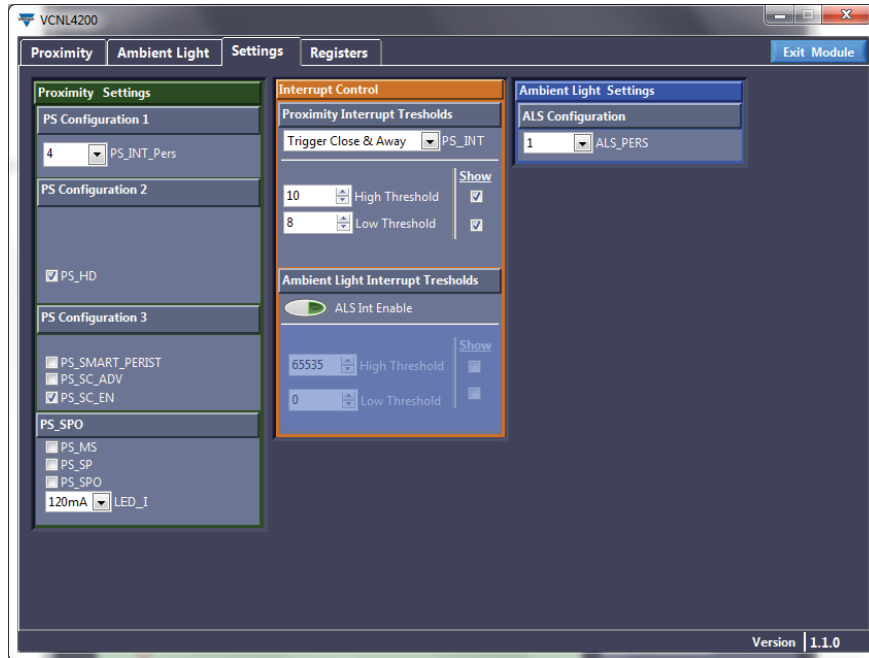

Fig. 31

4. Just one or two measurements above the threshold will not activate the interrupt.

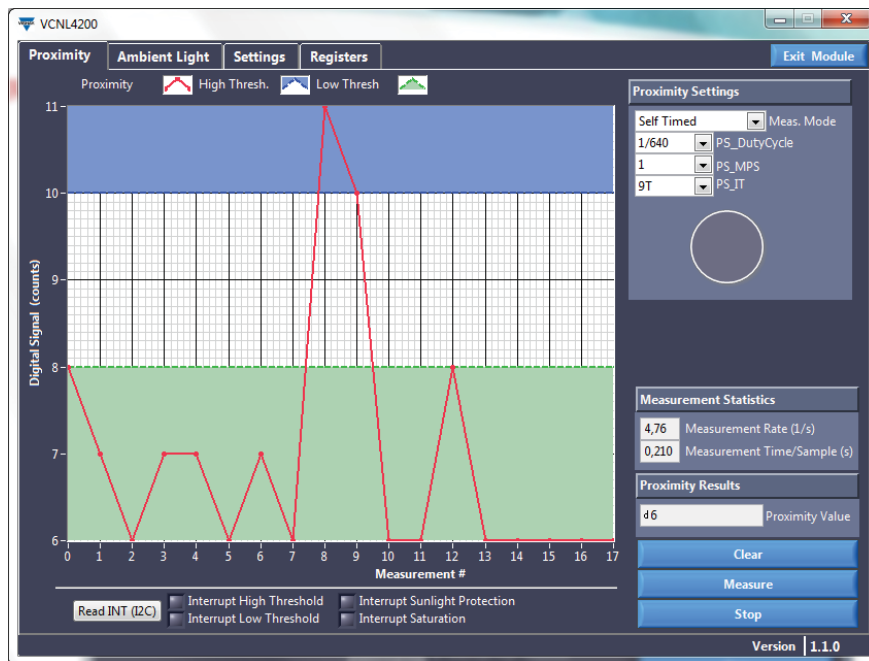

Fig. 32

Designing the VCNL4200 Into an Application

- With more than four measurements above the threshold, however, the interrupt is pulled low, as indicated by the red LED on the demo board and the red light: "Int Pin Triggered PS."

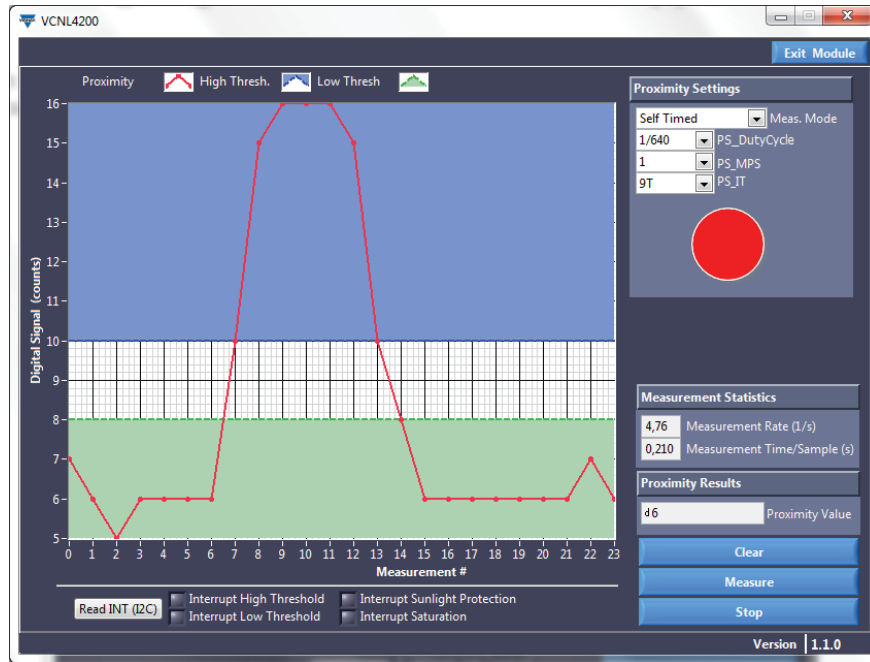

Fig. 33