



## **Scale Up Network Availability and Performance with Multi-port Gigabit Adapters**

Whether segmenting a small office network or migrating to consolidation and virtualization of a global datacenter, Gigabit Ethernet (GbE) adapters play a key role in maximizing network availability, reliability, and performance. This white paper provides an overview of how Intel® PRO Server Adapters address the high-performance demands of today's network environment.

April 2005

## Contents

The Increasing Demand for Network Speed, Reliability, and Availability .....	2
Expand Bandwidth with the Right Server I/O Architecture and Gigabit Adapters .....	3
The Present and Future of Interrupt Moderation.....	4
Use Advanced Adapter Technologies for Continuous Multi-Gigabit Performance.....	5
Segment Traffic Loads for Higher Performance and Availability.....	5
Adapter Teaming Optimizes Performance and Reliability.....	7
Consolidation and Virtualization Improve Agility and Reliability .....	9
10GbE as a High-Performance Network Backbone.....	11
Conclusion .....	11

## The Increasing Demand for Network Speed, Reliability, and Availability

Computer networks are now a ubiquitous, all-pervasive part of life. Lawyers, doctors, scientists, bankers, retailers, manufacturers, distributors, and others rely on some form of network connectivity to sell and deliver products and services. Even one-person real estate shops rely on network connectivity to access large, networked databases of property listings and agents. Additionally, the deployment of e-Commerce continues to spread, now encompassing our private lives with on-line bill paying, on-line shopping, and a host of other on-line, on-demand services and conveniences.

Not only is there an ever-broadening demand for services, but the required services are in themselves becoming more complex and demanding. Global weather modeling is perhaps one of the more esoteric examples of a highly complex and demanding application. A more mundane but equally demanding example is debit card purchases. Debit card use is now eclipsing both cash and check writing as the preferred consumer-transaction method. It works because it is quick, convenient, reliable, and available just about anywhere we go.

To meet such increased needs and expectations for speed, availability, and reliability throughout the broad scope of network applications, network engineers have developed varied architectural approaches. These approaches include network segmentation, multi-tier datacenters, and server consolidation and virtualization. In all of these methods, multiple or redundant network elements are combined to provide higher performance and reliability; a key element is multiple network connections, as provided with multi-port Intel® PRO/1000 Server Adapters.

This white paper provides an overview of how Intel PRO/1000 Server Adapters and LAN-on-motherboard (LOM) connections can be used to optimize network performance and reliability. In particular, dual-port LOM and quad-port GbE server adapters are emphasized because of their space efficiency in high-density server applications.

**Table 1. Intel® Architecture I/O configurations**

Interconnect	Bus Width	Bus Frequency	Raw Bus Bandwidth (Bytes per sec.)	Raw Bus Bandwidth (Bits per sec.)
PCI	32 bits	33 MHz	133 MBps	1 Gbps
PCI/PCI-X*	64 bits	66 MHz	533 MBps	4.2 Gbps
PCI-X	64 bits	100 MHz	800 MBps	6.4 Gbps
PCI-X	64 bits	133 MHz	1 GBps	8 Gbps

## Expand Bandwidth with the Right Server I/O Architecture and Gigabit Adapters

As a first step in enhancing network performance, make sure all network servers have the right input/output (I/O) architecture for optimum bandwidth. Doing so ensures delivery of the best server performance to the end-users on the network.

Intel® Architecture-based servers have various internal I/O capabilities, depending on the specific I/O slot configuration. The configurations range from 1 Gbps of raw bus bandwidth delivered by a Peripheral Component Interconnect (PCI) 2.3-compliant, 32-bit, 33-MHz bus to 8 Gbps of bandwidth delivered by a Peripheral Component Interconnect Extended (PCI-X\*) 1.0-compliant 64-bit, 133-MHz bus, as shown in Table 1.

As shown in Figure 1, the amount of I/O bandwidth that a server can support depends on the PCI-X bus speed. These bandwidths are:

- One slot at 133 MHz for 8 Gbps total raw bandwidth
- Two slots at 100 MHz for 6.4 Gbps total raw bandwidth
- Four slots at 66 MHz for 4.2 Gbps total raw bandwidth

In addition to deploying servers for the optimal bus bandwidth to meet performance needs, IT managers should also plan for the best performance attainable from the server adapters that will occupy the server's PCI-X slot(s). For example, by placing an Intel® PRO/1000 MT Quad Port Server Adapter into a PCI-X 133-MHz slot, all four Ethernet ports of the adapter will interface with the PCI-X bus at 133 MHz. By comparison, you can provide the same number of GbE ports with two Intel® PRO/1000 MT Dual Port Server Adapters in two PCI-X 100-MHz slots. However, in this two-slot configuration, all four ports interface with the PCI-X bus at 100 MHz, which is a 25-percent decrease in bandwidth—providing less raw bandwidth capacity.

Another factor to consider when selecting a server's I/O capability is the number of I/O slots provided. The range varies from rack servers and appliances that do not have PCI slots, to servers that have up to 12 slots. The number of I/O slots in a server typically follows server cost; but high-capacity adapters like the Intel PRO/1000 MT Quad Port Server Adapter allow high-bandwidth capacity—even in servers with fewer available I/O slots, such as the rack-mount servers typical in datacenters.

**Figure 1. PCI-X\* 1.0 specifies total slot capacity per bus speed**

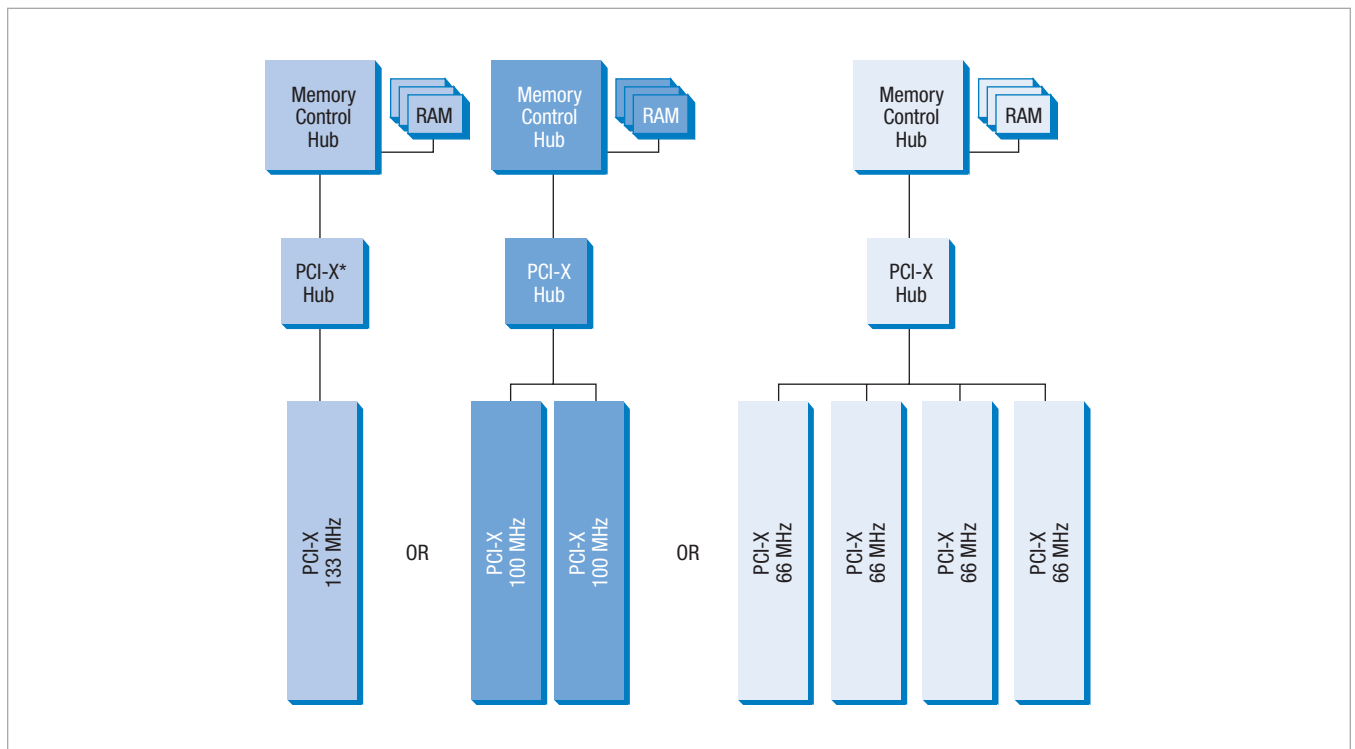

# The Present and Future of Interrupt Moderation

Advanced interrupt-moderation technology is here today. Interrupt moderation reduces host processor interrupts, thereby enabling technologies such as Gigabit EtherChannel\* to deliver more of their 16-Gbps bandwidth potential (8 Gbps x full duplex). As a result, performance gains from load-balancing used in adapter teaming will become a smaller part of overall performance as compared to the performance gains achieved through the increased server CPU headroom provided by interrupt moderation.

Host processor interrupts are generated by the adapter in order to request cycles for packet processing. These interrupts need to be controlled to achieve optimum throughput. Too few interrupts can lead to latencies and too many can unduly burden the server's processor. By bundling an appropriate number of packets before issuing an interrupt to the host (see figure), the adapter "tunes" interrupt frequency to match traffic conditions while maintaining packet flow.

Now that interrupt moderation is available on all Intel® PRO/1000 MT Server Adapters, here is an important tip for all network managers interested in taking advantage of this new technology: Look for interrupt-moderation methods that use dynamic timing adjustment, not just sampling—the more granular the timing, the better the performance.

For most networks, these technologies will provide the multi-Gigabit bandwidth needed for server and backbone connections, helping support today's movement to Gigabit Ethernet (GbE) at the desktop. Now that 10-Gigabit Ethernet (10GbE) server adapters are entering the marketplace for campus-to-campus connectivity, these technologies for link aggregation, load balancing, and interrupt moderation will continue to provide value to GbE deployed in the Local Area Network (LAN). At the very least, they enable organizations to implement a smoother and more cost-effective migration to 10GbE networking speeds.

## Host Interrupt Moderation

### Low-volume traffic

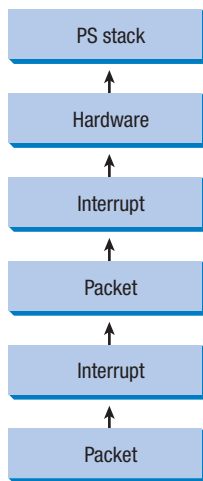

Each packet generates a host interrupt

### High-volume traffic

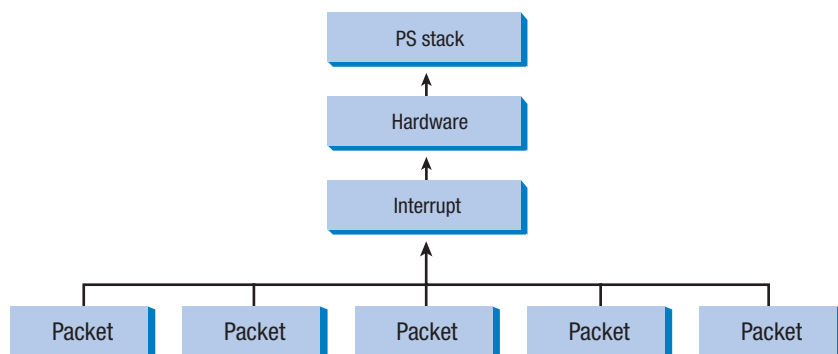

As volume increases, multiple packets are bundled for processing on a single interrupt

In general, today's increased server workloads are increasing the bandwidth requirements of any given server. A cost-effective way to deal with this higher bandwidth demand is to boost bandwidth with additional Ethernet ports beyond the one or two LOM connections provided on most server motherboards. Adding an Intel PRO/1000 MT Quad Port Server Adapter gives an additional 4 Gbps of network capacity—at 133 MHz PCI-X bus speed, if installed in a 133-MHz slot—while using only one server slot. This multi-port adapter approach conserves valuable PCI slots for other uses such as Redundant Array of Independent Disks (RAID) controllers, Secure Sockets Layer (SSL) encryption cards, or other devices.

## Use Advanced Adapter Technologies for Continuous Multi-Gigabit Performance

Not all server adapters are the same. A server adapter meeting the minimum Gigabit Ethernet requirements for network connection typically leaves the bulk of Transmission Control Protocol (TCP) checksum and packet-processing overhead to the host processor. This burdens the host with additional processing and can result in higher latencies, resulting in less-than-optimum performance.

Advanced technologies and functionality in Intel PRO/1000 Server Adapters, such as Large Send Offload (LSO), enable sustained multi-Gigabit performance. Testing by the Intel Labs

of the Intel PRO/1000 MT Quad Port Server Adapter resulted in nearly 4 Gbps throughput with LSO and Microsoft Windows 2000 Advanced Server\*/Microsoft Windows XP\*: LSO offloads and accelerates the packet-formation process, reducing the host processor's burden. This leaves headroom in the host processor for delivering multi-Gigabit performance.

Other advanced features provided in Intel PRO/1000 Server Adapters include interrupt moderation (see *The Present and Future of Interrupt Moderation* on page 4), auto-negotiation of adapter speed, and Intel® Advanced Network Services (ANS) software. These features make Intel PRO/1000 Server Adapters compatible with any existing Ethernet LOM or adapters on your currently installed server base. Together, the 10/100/1000 Mb auto-negotiate and Intel ANS features allow existing ports of any speed or brand to be teamed with Intel® PRO Gigabit adapters. This is important, for example, when upgrading legacy systems where existing Fast Ethernet LOM can still be useful as a redundant or back-up link. Also, discussed later in this paper, Intel ANS plays a key role in teaming server adapters for higher bandwidth and reliability.

## Segment Traffic Loads for Higher Performance and Availability

Network administrators can use multiple GbE adapters to segment their networks for a variety of reasons, including security, networked storage deployment, and improved traffic flow. Figure 2 shows a simple example, where a second network connector is added to the server in order to split the original network into two segments or subnets.

For a small-office, single-server LAN, the simple segmentation scheme in Figure 2 is a particularly quick and cost-effective method of essentially doubling network performance and availability. Each subnet still provides GbE performance; however, each subnet now sees only half the overall traffic, resulting in each client seeing faster network response and availability. The effect is analogous to adding a new lane to a crowded highway—traffic jams are alleviated by dispersing the traffic over more lanes, allowing all traffic to travel at a higher speed.

Adding a third server adapter and another subnet to the network (Figure 2) provides additional traffic-handling capability. Generally, three subnets per server is the accepted limit of segmentation. However, segmentation can be extended to include more subnets by adding another router-

Figure 2. Segmenting the network

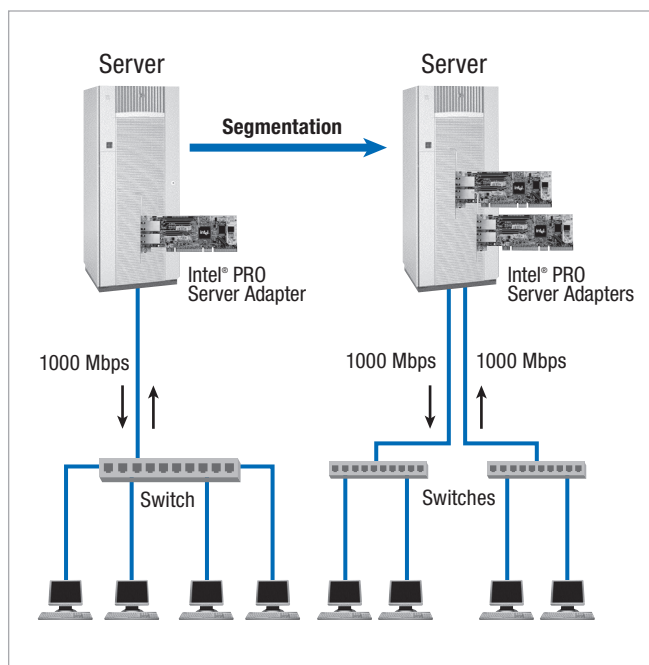
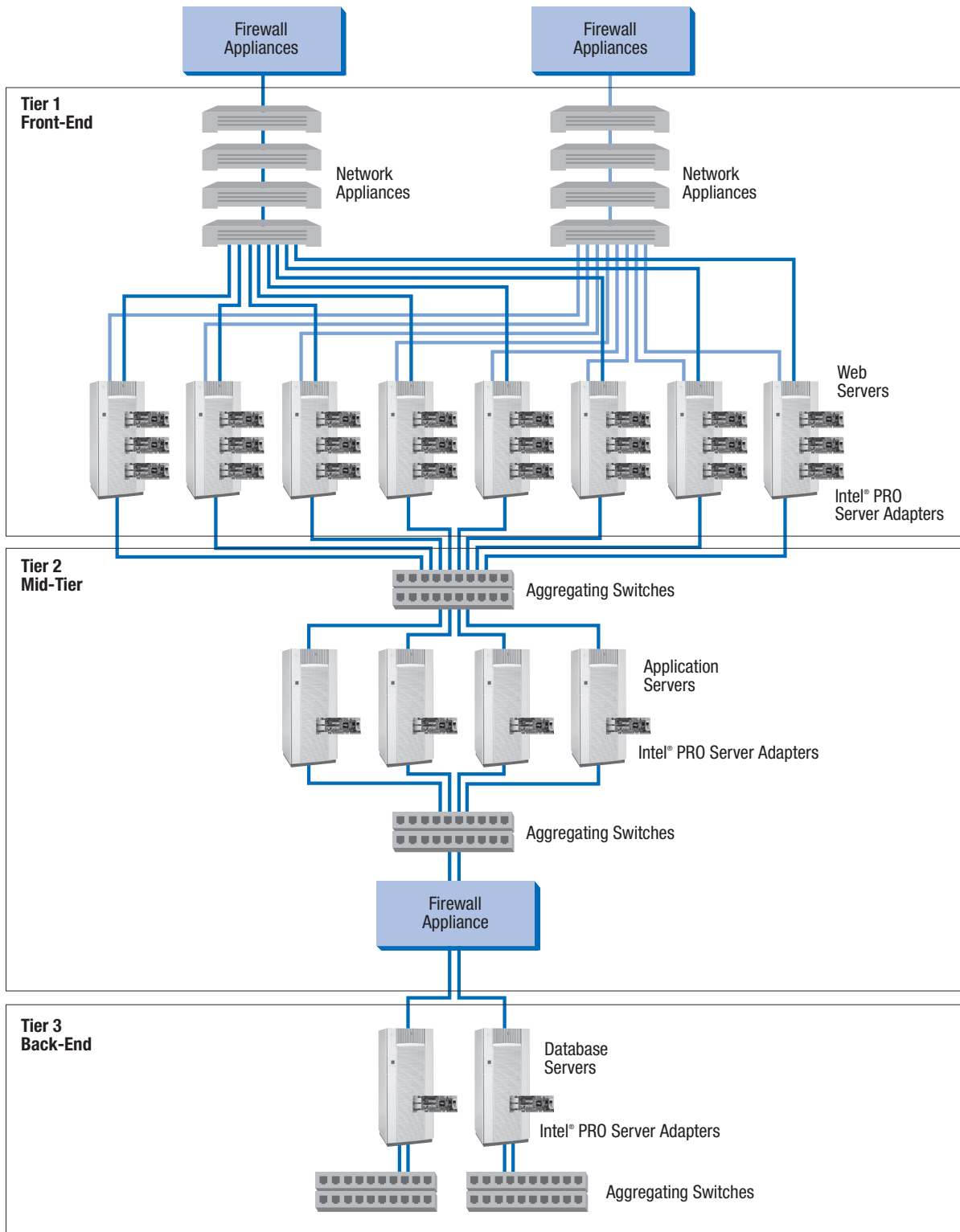

Figure 3. Three-tiered infrastructure separates and secures networks



connected server to the network—for a total of six subnets (three per server). This approach is useful in networking diverse work groups or applications on a single LAN and for providing additional security between work groups.<sup>1</sup>

Network segmentation can also be implemented as a multi-tiered infrastructure. Figure 3, on the previous page, depicts a three-tiered implementation, which separates and secures logical networks such as front-end Web servers, application servers, and back-end databases. This three-tiered approach is effective for scaling distinct parts of Internet-based applications required for e-Business. It is also the first recommended step in datacenter centralization prior to architecting server consolidation and virtualization.

Just as in simple segmentation, a multi-tiered approach also requires multiple network connections in each server, with each tier associated with an individual connection. To better balance network loads using segmentation in subnets and multi-tiered infrastructures, the Intel PRO/1000 MT Dual Port Server Adapter provides two GbE ports in a cost-effective, single-slot solution. Furthermore, by deploying multiple connections on each network segment, availability can be

greatly improved. For example, by putting the two LOM ports of the Intel® 82546EB Dual Port Gigabit Ethernet Controller on one network segment and the two ports of the Intel PRO/1000 MT Dual Port Server Adapter on another, redundant links are then available for the network segments of a given server. With such link redundancy, a failure of any one link will not result in a loss of connectivity and crippling downtime. Instead, the traffic fails over to the segment's redundant link and business continues uninhibited.

With today's organizations increasingly relying on powerful client systems and network-intensive applications, end-users and IT staff will benefit from deploying multiple GbE server adapters for their critical connections. GbE server adapters maintain higher network performance and reduce degradation in the event of a network failure, resulting in improved availability. To expand the server network resources required from the increasingly complex network architectures of today's enterprises, IT managers can deploy multi-port Intel PRO/1000 Server Adapters to relieve bottlenecks and boost system reliability.

## Adapter Teaming Optimizes Performance and Reliability

The additional GbE ports and links used in segmentation and multi-tiered approaches require additional management capability. This added management capability is provided with all Intel PRO/1000 Server Adapters via Intel ANS software. Not only does Intel ANS manage multiple Intel adapters by teaming them, but it allows adapters from other vendors to be included in the adapter teams. This latter feature, multi-vendor compatibility, allows existing non-Intel server LOMs to be included in adapter teaming for higher network performance and reliability.

Intel ANS provides the following hierarchy of three adapter-teaming categories:

- Adapter Fault Tolerance
- Adaptive Load Balancing
- Link Aggregation

Each builds on the previous hierarchical member, such that Adaptive Load Balancing includes Adapter Fault Tolerance and Link Aggregation includes both Adapter Fault Tolerance and Adaptive Load Balancing.

Figure 4 illustrates the basic concepts of how the various levels of adapter teaming benefit network performance and reliability. To start, the top server illustrates basic segmentation

Figure 4. Adapter teaming

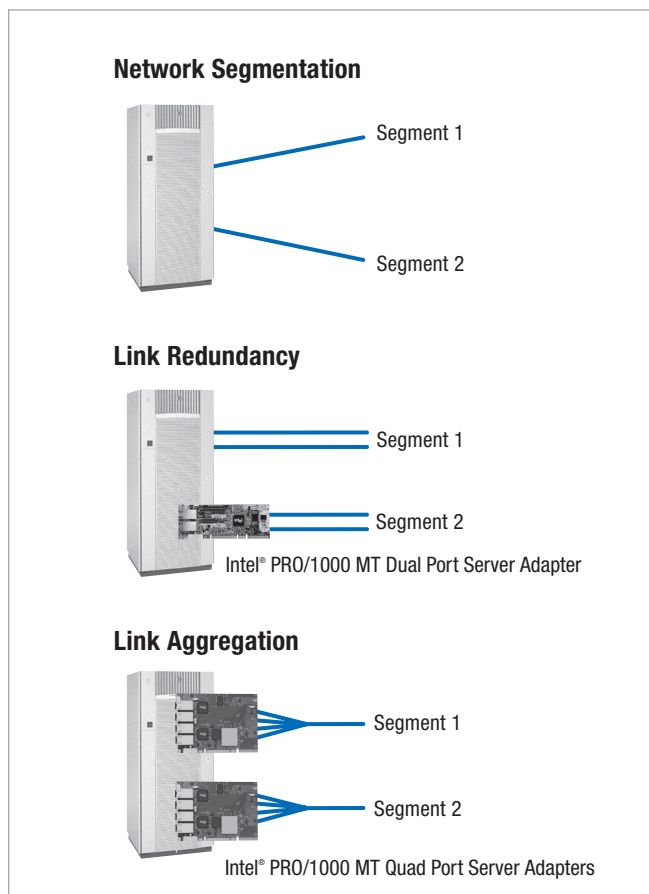

with two ports provided by LOM or server adapters. There is one GbE port and one link per segment. Adding redundancy with another port and link for each segment increases network reliability and availability. In the case of Link Redundancy (Figure 4 on the previous page), Segment 1 is set up on the server's dual-port LOM and an Intel PRO/1000 MT Dual Port Server Adapter has been added to serve the two links on Segment 2. Each segment now has a primary link and a secondary link. If the primary adapter or link fails, the Adapter Fault Tolerance feature automatically detects the connection failure and switches primary link traffic to the secondary link.

Adaptive Load Balancing allows redundant port and link teaming for higher traffic capacity as well as fault tolerance. In this mode, Intel ANS automatically analyzes segment traffic and balances it across the primary and secondary links to provide higher overall throughput along with the higher reliability and availability provided by automatic fault tolerance. In essence, another lane is added to the data highway.

The Link Aggregation feature of Intel ANS can team up to eight GbE ports and links into a single, larger pipe for even higher traffic capacity and reliability. In the case of Link Aggregation in Figure 4, an Intel PRO/1000 MT Quad Port Server Adapter connects each segment to the server with four teamed connections. All connections in the same team have the same address and appear as a single link from the switch perspective. Essentially, this is a four-lane freeway with traffic equally balanced across all lanes. And, if a lane gets shut down for any reason, three open traffic lanes still remain.

For the most demanding situations, Intel ANS can team as many as eight GbE ports and links into a single team. Figure 5 shows teaming of eight ports on two Intel PRO/1000 MT Quad Port Server Adapters using link aggregation. In practice, however, Intel ANS can team any mix of LOM, single-port or multi-port adapters as long as one of the adapters is an Intel® adapter. The teamed adapter ports allow transmit and receive on all eight channels, and cross-connected switches provide switch fault tolerance—all supported and managed by Intel ANS.

**Figure 5. IEEE 802.3ad\* link aggregation**

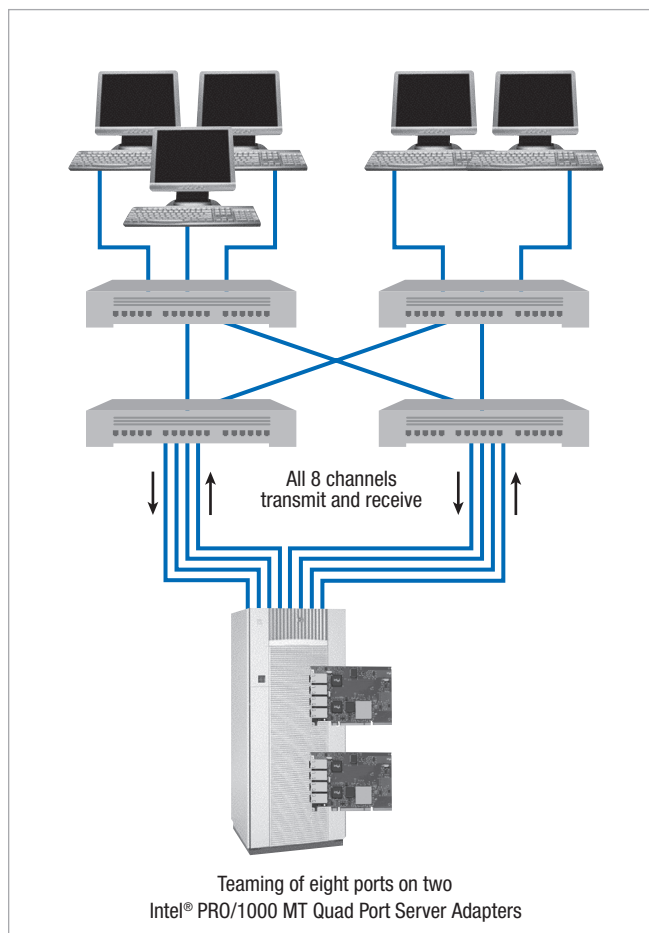

**Figure 6. Physical consolidation of servers**

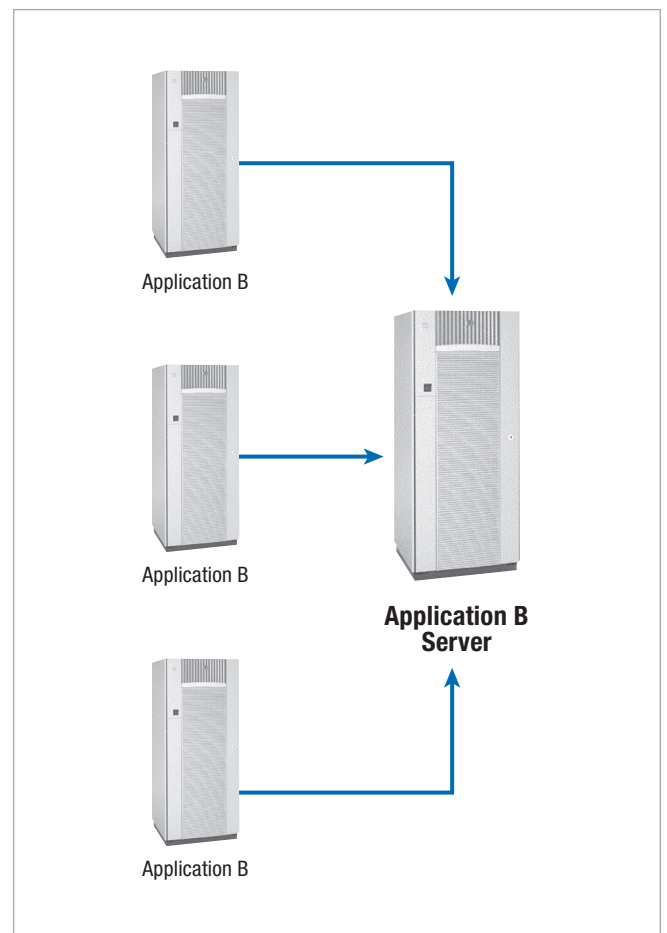



Several technologies enable the approach shown in Figure 5 on the previous page, including IEEE 802.3ad\* link aggregation, Adaptive Load Balancing from Intel and Gigabit EtherChannel\* from Cisco. All these technologies require support by both the GbE adapters and the switches. Intel PRO/1000 Server Adapters support the IEEE 802.3ad industry standard for link aggregation. The IEEE standard allows for balancing traffic among multiple server adapters and switches that also support the standard (Figure 5).

Developed by Intel to improve network performance, Adaptive Load Balancing increases server bandwidth by automatically balancing traffic across as many as eight server adapters. Because the distribution of traffic among the adapters is automatic, further segmenting or reconfiguration of the network is not needed. The existing Internet Protocol (IP) address is shared by all of the adapters; and traffic is always balanced among them. Developed by Cisco and supported by Intel, Gigabit Etherchannel provides scalable bandwidth for up to eight adapters at full duplex. It can potentially deliver well in excess of 8 Gbps.<sup>2</sup>

## Consolidation and Virtualization Improve Agility and Reliability

As businesses expand, their IT infrastructure also expands to meet increasing network end-user demands. Historically, such infrastructure expansion resulted in a proliferation of far-flung servers. For example, in retail clothing, Gap Inc. traditionally added a new server each time they added a new project or application. This one-application-per-server approach to growth ultimately resulted in Gap's IT group managing some 450 servers. Such server proliferation includes low utilization of server resources—as low as 10 percent for more than 300 of the servers—and increased management complexity.

Server consolidation and virtualization allowed Gap Inc. to consolidate one-third of its existing servers to just three 8-way Intel® Xeon™ processor MP-based servers. This high consolidation ratio provided significant savings in equipment and system-administration costs and, through virtualization, allowed configuration for high application availability with the potential to boost uptime to greater than 99.99 percent.<sup>3</sup>

Whether or not consolidation should be used, and to what degree, needs to be determined strategically on a case-by-case basis. Moreover, consolidation should be executed as a well-planned migration that does not interrupt day-to-day IT infrastructure operations.

In general, the four stages or steps to a well-executed consolidation effort are:

1. Centralization
2. Data consolidation
3. Physical consolidation (server consolidation)
4. Application consolidation

In all of these stages, server adapters play a key role because server-to-server and server-to-client connections must still occur. In fact, multi-port adapters become even more important as a means of providing high port-to-slot densities on consolidated servers.

As an example of server adapter importance, consider the first stage of consolidation, which is centralization. Centralization is simply the process of moving dispersed or far-flung servers to a centralized location for more efficient management. The three-tiered datacenter, discussed previously and illustrated in Figure 3 on page 6, is a prime example of centralization and server adapter importance in providing higher reliability and availability.

The second stage, data consolidation, involves moving data onto fewer, centralized databases and storage systems. This typically involves clustered or consolidated servers with Storage Area Networks (SANs) or Network Attached Storage (NAS).

Figure 6, on the previous page, illustrates the third stage, which is physical consolidation or server consolidation. This process consolidates multiple servers running the same application onto a single, large platform. Server consolidation, when done properly, can significantly reduce management costs and increase performance. This works particularly well in a three-tiered environment with separate Web servers, application servers, and database servers because each tier can be physically consolidated and scaled independently to match specific workload requirements.<sup>4</sup> In virtually all cases, realizing the full performance potential of such consolidation requires high-performance, highly reliable network connections such as those provided by teaming multi-port adapters for the much higher traffic capacity offered by link aggregation.

Application consolidation, the fourth and most complex stage, involves hosting multiple, diverse applications on a single platform. This is done with virtualization software that partitions the platform into multiple virtual machines running concurrently on a single platform. For example, VMware ESX Server\* virtualization software supports up to 64 concurrent virtual machines with half the available partitions live at any

**Figure 7. LAN with 10GbE backbone**

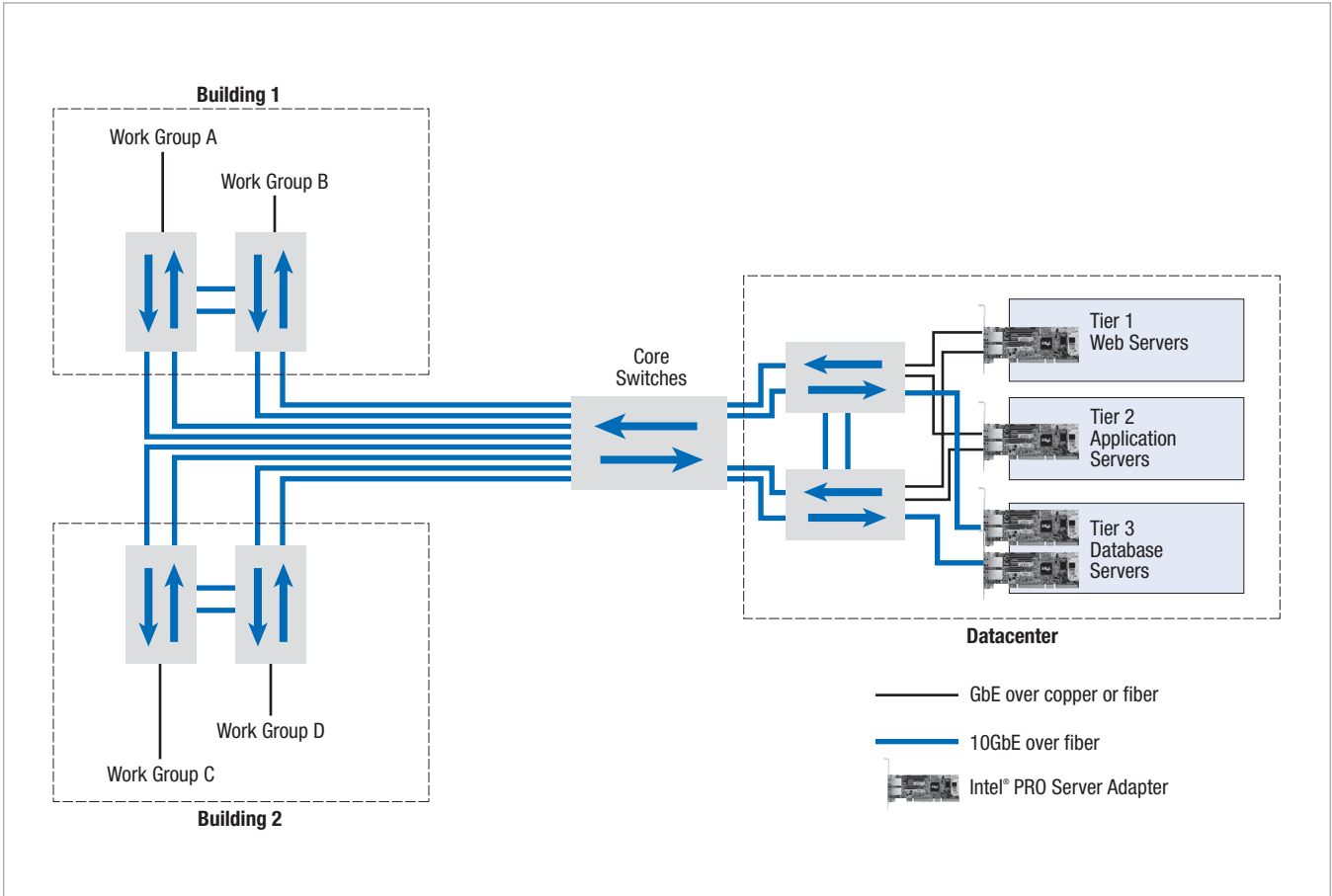

**Figure 8. 10 Gigabit Ethernet use in expanded LAN environments**

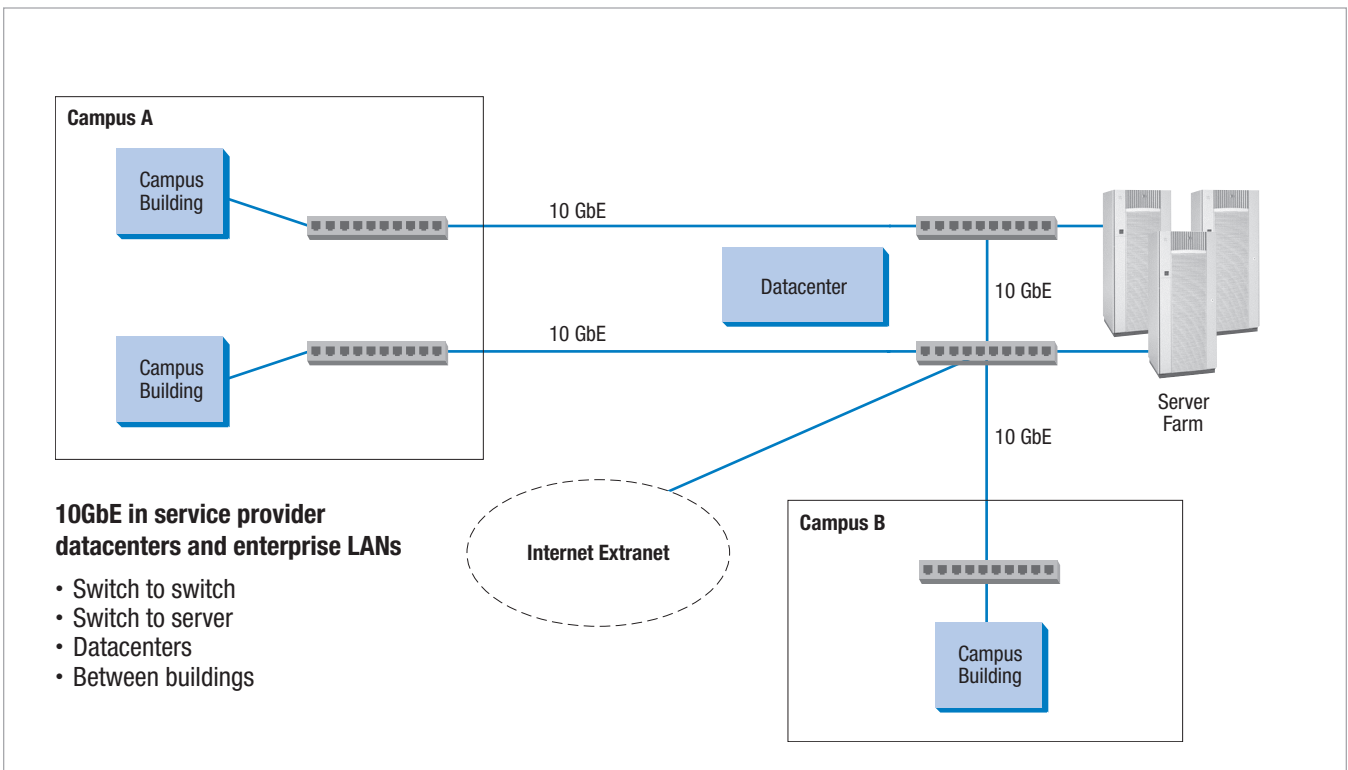

given time. The other 32 virtual machines remain available on fail-over standby in case of a hardware or software problem on any of the live virtual machines. The benefits of virtualization include smoothing of workload demands for higher system utilization, server redundancy without investing in additional servers, and the ability to create and assign virtual machines for high agility in meeting changing application demands.

Again, GbE server adapter connectivity is a key element in making virtualization work. With as many as 32 virtual machines running on a single high-performance platform, a substantial pool of GbE ports becomes necessary. Intel multi-port GbE server adapters allow such port count requirements to be met while conserving server PCI slots. Additionally, Intel ANS support for link aggregation and fault tolerance provides the connectivity resources necessary to support the higher performance, agility, and reliability levels achieved through server consolidation and virtualization.<sup>5</sup>

## 10GbE as a High-Performance Network Backbone

Some application environments may be better served by the higher bandwidth of 10GbE connectivity. Such applications typically generate extremely large files and rely on fast transfers of such files between various work groups and one or more centralizing database(s). Weather modeling is one such example. Motion picture production involving animated special effects or feature-length animation is another example. In this latter case, multiple animator workstations must all have quick access to huge animation files in a collaborative process that creates and manipulates film scenes and transfers them to a film production datacenter. Yet another example is Computer Aided Design (CAD) work groups involved in creating and simulating complex, interactive processes.

In cases involving only one or two small work groups demanding super-high performance, it may be possible to put those work groups on their own 10GbE network segments. In many cases, though, the situation is one of multiple work groups in widely separated locations, such as design in one building and production in another building.

These larger, more-spread-out networks may require a network infrastructure based on a 10GbE backbone between buildings with GbE distribution to the segments or subnets within each building. On the previous page, Figure 7 illustrates such an infrastructure based on a 10GbE backbone.

For applications requiring the added bandwidth of 10GbE, Intel offers two 10GbE server adapters. The Intel® PRO/10GbE SR Server Adapter provides cost-effective 10-Gigabit performance over distances up to 300 meters in multi-mode fiber-optic media, making it the ideal backbone choice for campus-wide LANs. The Intel® PRO/10GbE LR Server Adapter has a much longer reach—to 10 kilometers in single-mode fiber—and is an ideal choice for use in expanded LANs serving multiple campuses such as shown in Figure 8 on the previous page.<sup>6</sup>

## Conclusion

Multiple GbE adapters in servers enable greater network capacity, performance, and availability. With its maximum 8-Gbps throughput, the PCI-X specification provides enhanced network functionality when a multi-port Gigabit adapter, such as the Intel PRO/1000 MT Quad Port Server Adapter, is installed in a PCI-X 133-MHz slot. The Intel PRO/1000 MT Quad Port Server Adapter quickly increases network capacity while minimizing impact on available server slots that might be required for other critical I/O functions.

While network segmentation provides greater flexibility and availability in enterprise application deployment, both industry-standard and advanced technologies improve network performance. Teaming the multi-port Intel PRO/1000 MT Server Adapters with GbE LOM components that are embedded on motherboards provides the level of throughput, reliability, and availability demanded in a connected enterprise—from simple, small-office LANs to multi-tiered datacenters incorporating server consolidation and virtualization techniques.

When designing servers with multiple GbE adapters, be sure to specify the following types of Intel® PRO Gigabit Server Adapters:

#### **Intel® PRO Gigabit Ethernet Server Adapters for Copper Networks**

- Intel® PRO/1000 MT Quad Port Server Adapter
- Intel® PRO/1000 MT Dual Port Server Adapter
- Intel® PRO/1000 MT Server Adapter

#### **Intel® PRO Gigabit Ethernet Server Adapters for Fiber Optic Networks**

- Intel® PRO/1000 MF Dual Port Server Adapter
- Intel® PRO/1000 MF Server Adapter
- Intel® PRO/1000 MF Server Adapter LX
- Intel® PRO/1000 XF Server Adapter

#### **LAN-on-Motherboard Connections**

- Intel® 82546EB Dual Port Gigabit Ethernet Controller
- Intel® 82545EM Gigabit Ethernet Controller

For high-speed backbones, campus LANs, and expanded LAN environments, be sure to specify the following types of Intel® PRO/10GbE Server Adapters:

#### **Intel® PRO 10 Gigabit Ethernet Server Adapters for Fiber Optic Networks**

- Intel® PRO/10GbE SR Server Adapter
- Intel® PRO/10GbE LR Server Adapter

**For more information on Intel® PRO Network Connections, visit:**  
[www.intel.com/network/connectivity](http://www.intel.com/network/connectivity)

**For more information on multi-port Intel® PRO Server Adapters, visit:**  
[www.intel.com/network/connectivity/solutions/gigabit.htm](http://www.intel.com/network/connectivity/solutions/gigabit.htm)

<sup>1</sup>For more information on segmentation, refer to *Using Segmentation to Increase Network Performance*, an Intel white paper available at [www.intel.com/network/connectivity/resources/doc\\_library/white\\_papers/305141.htm](http://www.intel.com/network/connectivity/resources/doc_library/white_papers/305141.htm).

<sup>2</sup>For more information on adapter teaming, refer to *Intel® Advanced Network Services Software*, an Intel white paper available at [www.intel.com/network/connectivity/resources/doc\\_library/white\\_papers/254031.pdf](http://www.intel.com/network/connectivity/resources/doc_library/white_papers/254031.pdf).

<sup>3</sup>For more information on consolidation and virtualization at Gap Inc., refer to *Intel® Solution Services Bridges the Gap to Server Consolidation*, an Intel Business Center Engagement Synopsis available at [http://cache-www.intel.com/cd/00/00/14/85/148583\\_148583.pdf](http://cache-www.intel.com/cd/00/00/14/85/148583_148583.pdf).

<sup>4</sup>For more information on server consolidation, refer to *Strategic Consolidation on Intel® Architecture-Based Servers*, an Intel white paper available at [www.intel.com/business/bss/products/server/strategic\\_consolidation.pdf](http://www.intel.com/business/bss/products/server/strategic_consolidation.pdf).

<sup>5</sup>For more information on multiport server adapters and their role in virtualization, refer to *Virtual Infrastructure: Multiport NICs Are Critical When Consolidating Servers and Improving IT Management Through Virtualization*, an Intel and VMware Inc. white paper available at [www.vmware.com/partners/hw/intel.html](http://www.vmware.com/partners/hw/intel.html).

<sup>6</sup>For more information on 10 Gigabit Ethernet, refer to *10 Gigabit Ethernet Technology Overview*, an Intel white paper available at [www.intel.com/network/connectivity/resources/doc\\_library/white\\_papers/pro10gbe\\_lr\\_sa\\_wp.pdf](http://www.intel.com/network/connectivity/resources/doc_library/white_papers/pro10gbe_lr_sa_wp.pdf).

This document and related materials and information are provided “as is” with no warranties, express or implied, including but not limited to any implied warranty of merchantability, fitness for a particular purpose, non-infringement of intellectual property rights, or any warranty otherwise arising out of any proposal, specification, or sample. Intel assumes no responsibility for any errors contained in this document and has no liabilities or obligations for any damages arising from or in connection with the use of this document.

Intel, the Intel logo, and Intel Xeon are trademarks or registered trademarks of Intel Corporation or its subsidiaries in the United States and other countries.

<sup>\*</sup>Other names and brands may be claimed as the property of others.  
Copyright © 2005 Intel Corporation. All rights reserved.

