

LPS331AP

high-resolution MEMS pressure sensor



LPS331AP pressure sensor enables 3D indoor positioning and enhanced GPS in portable devices

From 750 m below ground to the top of Mount Everest, smartphones and other portable devices will soon be able to pinpoint their height relative to sea level to better than one meter, using the most recent MEMS (micro-electromechanical systems) pressure sensors from STMicroelectronics. The new LPS331AP is a tiny silicon pressure sensor that provides high-resolution measurements of pressure in an ultra-compact package ideal for use in smartphones, tablet PCs and handheld GPS.

KEY FEATURES

- 260 to 1260 mbar absolute pressure range
- High-resolution mode: 0.020 mbar RMS
- Low power consumption:
 - Low resolution mode: 5.5 μ A
 - High resolution mode: 30 μ A
- High overpressure capability: 20x full scale
- Embedded temperature compensation
- Embedded 24-bit ADC
- Selectable ODR from 1 Hz to 25 Hz
- SPI and I²C interfaces
- Supply voltage: 1.71 to 3.6 V
- High shock survivability: 10,000g

KEY BENEFITS

- Able to detect altitude variation in centimeters
- Ideal for battery-powered applications
- Optional external SW compensation for improved performance*

TARGETED APPLICATIONS

- Indoor and outdoor navigation
- Enhanced GPS for dead-reckoning
- Altimeter and barometer for portable devices
- Weather station equipment
- Sport watches



ABSOLUTE DIGITAL OUTPUT BAROMETER

The LPS331AP is an ultra-compact absolute piezoresistive pressure sensor. It includes a monolithic sensing element and an IC interface able to take the information from the sensing element and to provide a digital signal to the external world. The sensing element consists of a suspended membrane inside a single mono-

silicon substrate. It is capable of detecting pressure and is manufactured using a specific proprietary process called VENSENS. The VENSENS process allows a mono-silicon membrane to be produced above an air cavity with controlled gap and defined pressure. The membrane is very small compared to traditional silicon micromachined membranes. Membrane breakage is prevented by intrinsic mechanical stoppers.

The IC interface is manufactured using a standard CMOS process. This allows a high level of integration to design a dedicated circuit which is trimmed to better match the sensing element characteristics. The LPS331AP is available in a small plastic land grid array (HCLGA) package and is guaranteed to operate over an extended temperature range from -40 to +85 °C. The package is holed to allow external pressure to reach the sensing element.

LPS331AP BLOCK DIAGRAM

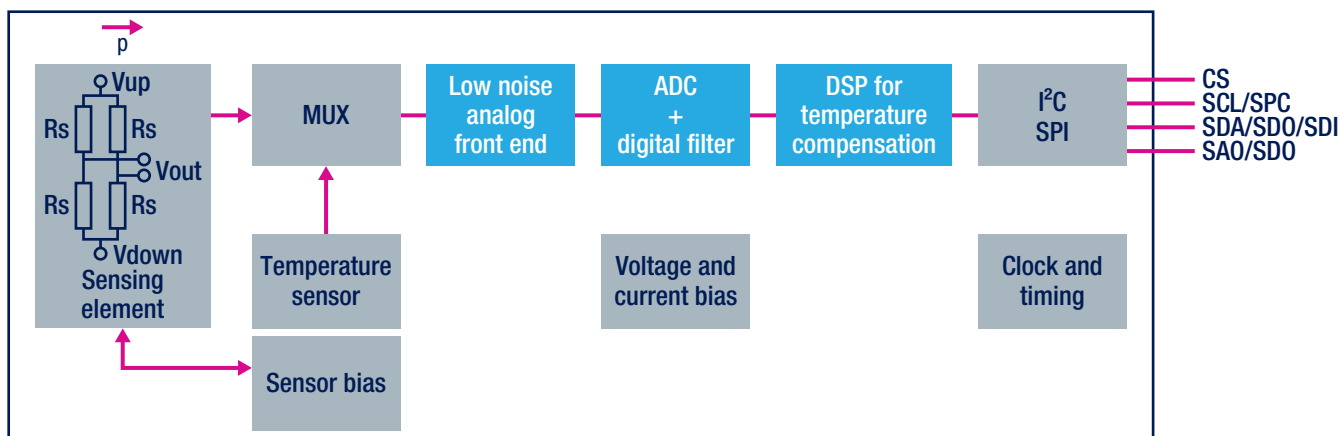

EVALUATION KIT

ST's pressure sensors are supported by an evaluation kit that consists of a motherboard (STEVAL-MKI109V2) and a plug-in module that includes the LPS331AP sensor (STEVAL-MKI120V1). Once the adapter is plugged in, the board can be connected to a host PC via USB so the device's capabilities can be easily evaluated via an intuitive graphic user interface. For further information go to www.st.com/mems.

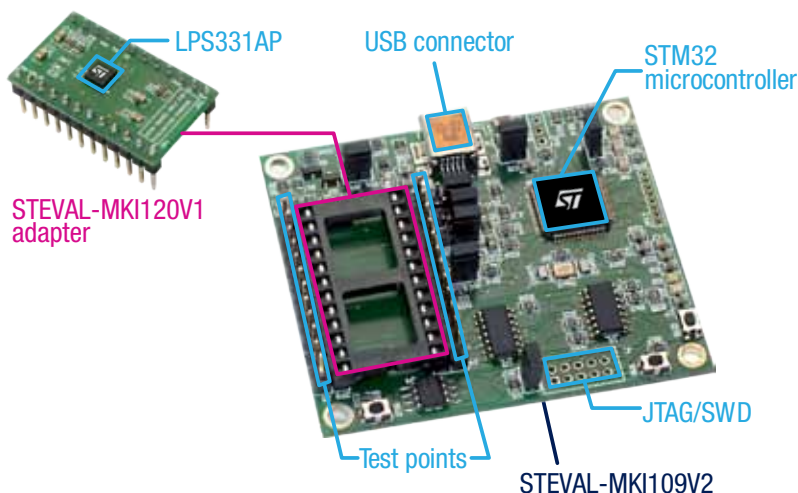

DEVICE SUMMARY

Order codes	Temperature range (°C)	Package	Packing
LPS331APY	-40 to +85	HCLGA-16L	Tray
LPS331APTR			Tape and reel
Evaluation boards	Description		
STEVAL-MKI109V2	Motherboard based on STM32. It features a DIL24 socket where every ST's MEMS adapter can be plugged in		
STEVAL-MKI120V1	Adapter board that enables fast system prototyping and LPS331AP evaluation		

Note: *software provided together with the companion chip



© STMicroelectronics - September 2012 - Printed in United Kingdom - All rights reserved
The STMicroelectronics corporate logo is a registered trademark of the STMicroelectronics group of companies
All other names are the property of their respective owners

