

# wi2wi<sup>®</sup>

Wireless 2 Wireless

## GPS Module W2SG0006

### Product Datasheet

A06-PDT-DOC Revision 1.62  
July 9, 2009



## Table of Contents

1	General Description.....	4
2	Features.....	4
2.1	Pin Definition .....	5
2.2	Pin Configuration.....	6
2.3	System Block Diagram .....	6
3	Specifications.....	7
3.1	Clock Frequency .....	7
3.2	Absolute Maximums Ratings.....	7
3.3	Interfaces.....	7
3.3.1	Host UART Interface .....	7
3.3.2	GPIOs .....	7
3.3.3	GPS and Flash Enable .....	8
3.4	Electrical/RF Characteristics: Operating .....	8
3.5	Performance.....	9
3.5.1	Acquisition Time .....	9
3.5.2	Position Accuracy (3-D NAV) .....	9
3.6	Environmental Characteristics .....	10
3.7	Antenna .....	10
3.8	Normal Operation Implementation .....	10
3.9	Backup Cell and Main Battery Implementation .....	11
3.10	Flash Enable/Firmware Upgrade Implementation.....	11
4	Development Support .....	12
5	NMEA Input and Output Messages.....	12
5.1	NMEA Output Messages.....	12
5.2	NMEA Input Messages .....	13
6	SiRF Binary Input and Output Messages .....	13
6.1	SiRF Binary Output Messages.....	13
6.2	SiRF Binary Input Messages.....	15
7	Mechanical Information .....	16
7.1	Mechanical Specification.....	16
7.2	Outline Drawing.....	16
7.3	Recommended PCB Layout.....	16
7.4	Recommended Reflow Profile.....	17
8	Disclaimers .....	18
8.1	Data Sheet Status .....	19
9	Firmware Settings.....	19
10	Part Numbering.....	19
11	Certifications .....	19
12	References .....	20
12.1	Specifications .....	20
12.2	Trademarks, Patents and Licenses .....	20
12.3	Other .....	20

List of Figures:

**Figure 1: Pin Configuration (Top View).....6**  
**Figure 2: System Block Diagram.....6**  
**Figure 3: Normal Operation Implementation.....10**  
**Figure 4: Battery and Backup Cell Connections .....11**  
**Figure 5: Flash Enabling for Programming.....11**  
**Figure 6: Package Outline Drawing.....16**  
**Figure 7: Recommended PCB Layout .....16**  
**Figure 8: Recommended Reflow Profile.....18**

List of Tables:

**Table 1: Pin Definition.....5**  
**Table 2: Absolute Maximum Ratings .....7**  
**Table 3: Operating Electrical Characteristics .....8**  
**Table 4: Average Time to First Fix .....9**  
**Table 5: Positional Accuracy .....9**  
**Table 6: Environmental Characteristics.....10**  
**Table 7: NMEA Output Messages.....12**  
**Table 8: NMEA Input Messages.....13**  
**Table 9: SiRF Binary Output Messages.....14**  
**Table 10: SiRF Binary Input Messages .....15**  
**Table 11: Mechanical Characteristics.....16**

**Change History**

Revision	Revision Date	Originator	Changes
1.0	01/18/2007	DS	Preliminary release.
1.1	03/01/2007	DS	Added normal & programming mode operations, physical dimensions, recommended PCB layout
1.2	03/01/2007	DS	Added battery and backup cell connections
1.3	03/19/2007	DS	Updated current consumption numbers based on GSC3F/LP; added Korea certification
1.4	07/24/2007	DS	Added pin descriptions; added firmware settings; added part numbering; updated reflow profile; added NMEA and SiRF Binary message summary.
1.5	3/13/2008	EK	Updated all diagrams' and/or figures' information and formatting, cover page, pin description table, and all information has been revised or added to
1.6/[1.61]	2/1/2009 [6/19/09]	AP/[EK]	Updated pin descriptions and information on development tools [EK FORMATTED DATASHEET]
1.62	7/9/09	EK	Formatted/Removed Confidential Information/Markings

## 1 General Description

This specification provides a general guideline on the performance and the integration of the Wi2Wi, Inc. NAVSTAR L1C/A Band, 20 Channel GPS Receiver Module Solution. The solder-down module, Part Number W2SG0006, is targeted to assist companies to easily integrate GPS functionally into their products. This is accomplished by reducing their development times and cost by using a complete, small form factor, low power, ready to integrate GPS Receiver System Solution.

The specification maximum and minimum limits presented herein are those guaranteed when the unit is integrated into the Wi2Wi, Inc. W2SG0006-DEV Development System. These limits are to serve as the representative performance characteristics of the W2SG0006 when properly designed into a customer's product. Wi2Wi makes no warranty, implied or otherwise specified, with respect to the customer's design and the performance characteristics presented in this specification.

## 2 Features

The Wi2Wi W2SG0006 is a 20 Channel Global Position System (GPS) receiver surface mount device (SMD) solution. Based upon the SiRFstar III™ technology, the SMD features fast acquisition times, high receiver sensitivity and low power consumption in a small, compact form factor. The W2SG0006 is a flexible design that supports a broad range of applications where GPS functionality and location based services is required.

Key features of the W2SG0006 are as follows:

- GPS technology based upon by the SiRF Technologies™ SiRFStar III™
- Compact design for easy integration: 15mm x 15mm x 2.5mm (including shield)
- Fast acquisition time and high sensitivity GPS Receiver
- Ultra-low power consumption.
- Surface Mount Design (SMD)
- 50Ω Antenna Launch
- 20 channel GPS receiver
- Multi-path Mitigation
- Uses NAVSTAR GPS L1 C/A signal
- SBAS (WAAS, ENGOS and MSAS) support
- Single 3.3 VDC supply input
- Two Configurable UART Interfaces
- Available Software accelerator for improved sensitivity: Satellite acquisition and tracking
- Format Selectable Output Data: NMEA, SiRFBinary™ and AI3/F
- Compatible with SiRF Technologies GSW3 Software
- RoHS Compliant

## 2.1 Pin Definition

The functional pin definition for the W2SG0006 is presented below in Table 1.

**Table 1: Pin Definition**

Pin	Signal	Type	Description
1	GND	PWR	Ground
2	GND	PWR	Ground
3	GPIO9	I/O	General Purpose I/O; Default configuration is for generating 1PPS Time Mark Output; Leave unconnected if it is not used
4	VDD_3V3	I	3.3V Power supply
5	GPS_ENABLE	I	GPS Enable; Connect to ground if there is no external control
6	FLASH_ENABLE	I	Flash programming; Pull high to 3.3V DC for flash mode and pull low for normal operation
7	GND	PWR	Ground
8	GPIO4	I/O	General Purpose I/O; Leave unconnected if it is not used
9	GPIO13	I/O	General Purpose I/O; Leave unconnected if it is not used
10	GND	PWR	Ground
11	GPIO14	I/O	General Purpose I/O; Leave unconnected if it is not used
12	GPIO1	I/O	General Purpose I/O; Leave unconnected if it is not used
13	GND	PWR	Ground
14	BACKUP_CELL	PWR	Connect to the backup battery as shown in Figure 4; Leave unconnected if it is not used
15	GND	PWR	Ground
16	RXA	I	UART Input Port for Channel A; Maximum voltage at this port should be 3.0V.
17	TXA	O	UART Output Port for Channel A; Maximum output voltage at this port is 3.0V.
18	GND	PWR	Ground
19	VDD_3V3	I	3.3V power supply
20	VCC_LNA	O	2.85V DC Regulated Output
21	VCC_ANT	I	Active antenna bias input; Connect to 3.3V DC is using active antenna; Leave unconnected if using passive antenna
22	ANT_IN	I	Antenna RF Input (50 ohm impedance)
23	GND	PWR	Ground
24	RTC_OUT	O	It is the output of the crystal oscillator located in the RF section of the chip; It is for monitoring purposes only and should be left unconnected if it is not used.
25	RXB	O	UART Input Port for Channel B; Maximum voltage at this port should be 3.0V.
26	TXB	I	UART Output Port for Channel B; Maximum output voltage at this port is 3.0V.
27	ECLK	I	External CMOS clock input only for AGPS applications under SiRFLoc Client software; Leave unconnected if it is not used
28	TIMESYNC (YCLK)	I	Timesync(Yclk) is an auxiliary clock input that supports alternate oscillator calibration system; It is used to for SiRFLoc Client time aiding information; Leave unconnected if it is not used

## 2.2 Pin Configuration

The W2SG0006 is a 28 pin SMD device. The pin definition is presented below in Figure 1.

Figure 1: Pin Configuration (Top View)

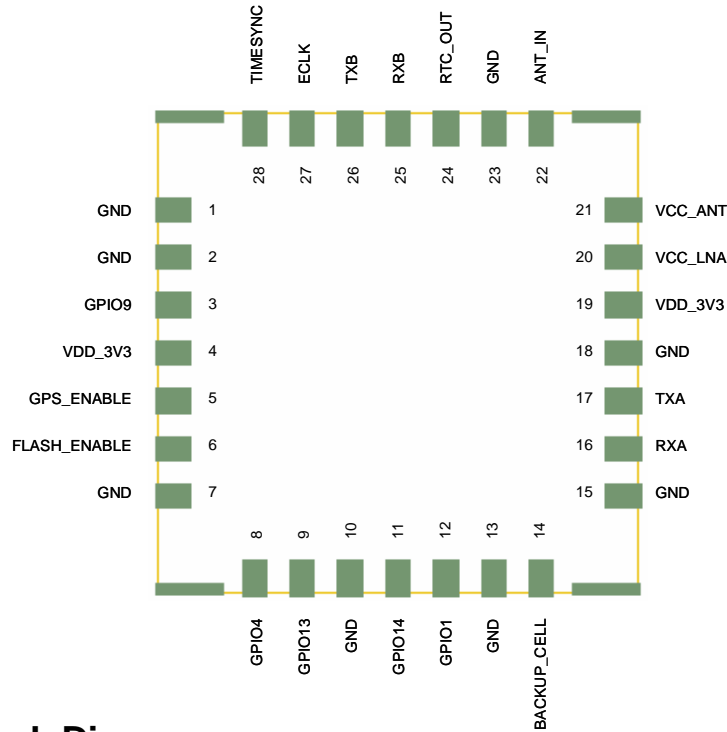

## 2.3 System Block Diagram

The System Block for the W2SG0006 is presented below in Figure 2.

Figure 2: System Block Diagram

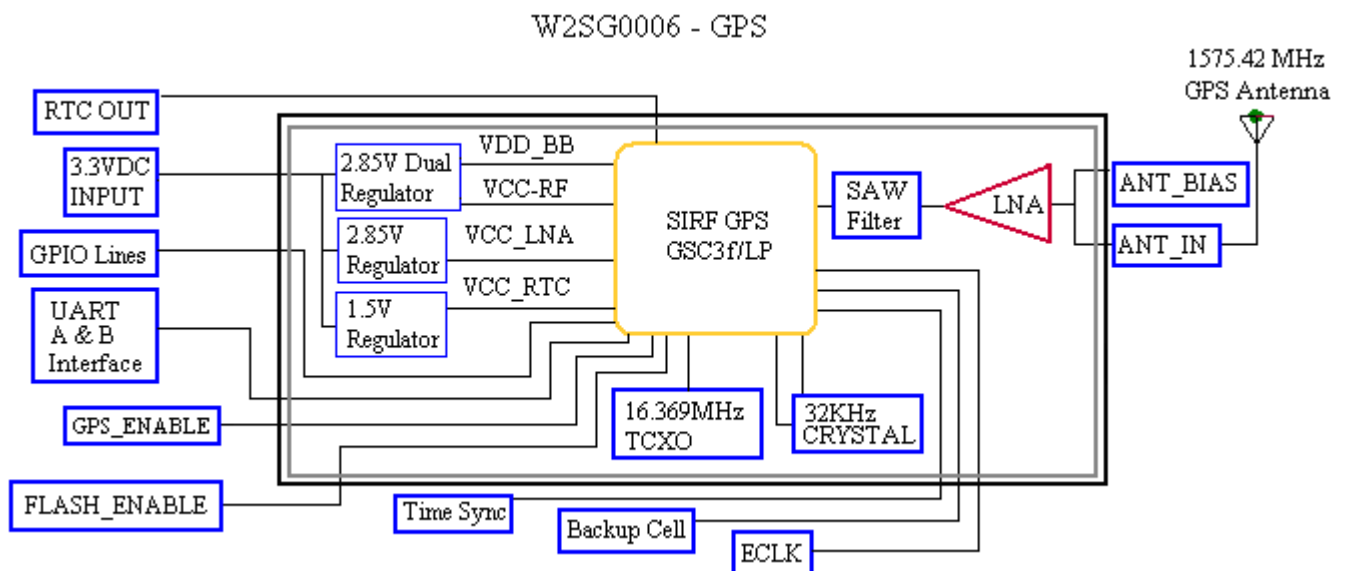

The W2SG0006 provides an internal LNA, all required power regulation, and clocking. The TTL UART Interfaces are accessed via Pin 15, 16, 25 and 26. Five programmable GPIOs pins are also available. The module also features an output supply for an external LNA (Pin 20) and an input for an Active Antenna Supply Voltage (Pin21).

## 3 Specifications

### 3.1 Clock Frequency

The W2SG0006 features an internal clock and crystal and requires no external clock sources. The W2SG0006 has two operating frequencies depending upon operational mode.

Full Power Mode:  $f = 16.396$  MHz

Full Power Mode and Power Save Mode:  $f = 32.768$  kHz

### 3.2 Absolute Maximums Ratings

The values presented below in Table 2 are those parameters beyond which permanent damage could result. These values *do not* imply functional operation and should be considered as stress ratings only.

Table 2: Absolute Maximum Ratings

Parameter	Symbol	Max.	Units
<b>Power Supply</b>			
Input Voltage	$V_{DD}$	3.6	V
Input Current	$I_{DD}$	70	mA
RF Input	$RF_{IN}$	0	dBm
Lead Temperature (Soldering, 10sec)	$T_{MFG}$	260	C°
Operating Temperature Range	$T_A$	-30 to +85	C°
Storage Temperature Range	$T_S$	-40 to +85	C°

### 3.3 Interfaces

#### 3.3.1 Host UART Interface

The TTL UART Interfaces (pins 16, 17, 25, 26) has a bit rate range of 1.2kbps to 115.2 kbps. Protocol options for the W2SG0006 are NMEA, SiRFBINARY™, and AI3/F. Default setting for the UART Interface A (pins 16, 17) is 9.6 kbps NMEA protocol and the default setting for the UART interface B (pins 25, 26) is 57.6kbps SiRFBINARY protocol. In the default firmware, where both the UART ports are enabled, the user cannot switch between communication protocols on the UART ports using external commands. Any configuration change required needs to be implemented at the firmware level. Wi2Wi can make these changes based on customer requirements.

#### 3.3.2 GPIOs

The W2SG0006 provides five GPIO pins (Pins 3, 8, 9, 11, 12) for various applications. The developer may use SiRF's GSW3 Software tools to configure these GPIO pins.

### 3.3.3 GPS and Flash Enable

The W2SG0006 provides Host enable input lines for GPS (Pin 5). If there is no external control of the module, then the GPS\_ENABLE (Pin 5) should be tied to ground.

For Programming or Firmware Upgrades the FLASH\_ENABLE (Pin 6) must be set high to 3.3VDC. Note: the module will not function as a GPS receiver with the FLASH\_ENABLE set high.

## 3.4 Electrical/RF Characteristics: Operating

The Table 3 below presents the normal limits of operation for the W2SG0006. Operation of the W2SG0006 beyond the limits of this table is not recommended and may result in permanent damage of the device. Unless otherwise specified, operating conditions are over  $T_A = -30\text{ C}^\circ$  to  $+85\text{ C}^\circ$ . Typical is defined as  $T_A = +25\text{ C}^\circ$ .

**Table 3: Operating Electrical Characteristics**

Parameter <sup>1</sup>	Symbol	Min	Typ	Max	Units
<b>Power Supply</b>					
Power Supply Voltage	$V_{CC}$	3.2	3.3	3.6	V
I/O Supply Voltage	$V_{IO}$	1.71	1.8	1.89	V
Power Supply Ripple	$V_{RIP}$	0	-	30	mV
Peak Supply Current <sup>2</sup>	$I_{CCP}$	-	-	70	mA
Power Supply Input Current <sup>3</sup>	$I_{CC}$	-	-	45	mA
Sleep Mode Input Current	$I_{SM}$	-	-	74	$\mu$ A
I/O Input Current	$I_{IO}$	-	1.5	2.0	mA
<b>UART Interface</b>					
Input Pin Voltage	VRX	1.8	-	3.0	V
Output Pin Voltage	VTX	1.8	-	3.0	V
<b>GPIO Interface</b>					
GPIO Pin Voltage	$V_{GPIO}$		2.85		V
<b>GPS Enable</b>					
Input Pin Low Voltage	$V_{IL}$	-	-	0.2	V
Input Pin High Voltage	$V_{IH}$	.8	-	3.0	V
<b>Flash Enable</b>					
Input Pin Low Voltage	$V_{IL}$	-	-	0.2	V
Input Pin High Voltage	$V_{IH}$	-	3.3	3.6	V
<b>RF Input</b>					
Input Impedance	$R_{ANT}$	-	50	-	$\Omega$
Operating Frequency	$F_{OPR}$	-	1.575	-	GHz
Antenna Bias Voltage	$V_{ANT}$	3.00	3.3	3.6	V
Antenna Bias Voltage Drop	$V_{ANTD}$	-	200	-	mV
RF Antenna Voltage	$V_{CCRF}$	-	3.1	-	V
RF Antenna Output Current	$I_{CCRF}$	-	-	22	mA
<b>RF Characteristics</b>					
Power In @1.5745 GHz	$P_{IN}$	-159	-130	-7	dBm
Noise Figure	NF		1.4		dB
Input IP2 ( $f_1=849\text{MHz}$ , $f_2=2424\text{MHz}$ )	IIP2		0.5		dBm
Input IP3 ( $f_1=1574.5\text{MHz}$ , $f_2=1575.5\text{MHz}$ )	IIP3		3		dBm
Input Return Loss	$RL_{IN}$		-10		dB

Input VWR	VWR <sub>IN</sub>		2.0:1		
Reverse Isolation	ISL		-28		dB
Stability (100 -10000 MHz)	Unconditionally Stable				
Receiver Sensitivity:					
•Signal Acquisition @ 31dBHz	P <sub>AQC</sub>	-142	-	-	dBm
•Signal Tracking	P <sub>TKS</sub>	-157	-139	-122	dBm

**Notes:**

<sup>1</sup> All parameters are at TA = 25C°, unless otherwise specified.

<sup>2</sup> Defined as peak current drawn during initial acquisition operation of GPS Receiver.

<sup>3</sup> Defined as current drawn during continuous operation at a 10Hz update rate.

### 3.5 Performance

#### 3.5.1 Acquisition Time

The average Time to First Fix (TTFF) for the W2SG0006 when integrated with the W2SG0006-DEV Development System is presented in Table 4 below:

**Table 4: Average Time to First Fix**

Parameter <sup>1</sup>	Symbol	Min	Typ	Max	Units
Hot Start – Typ. Signal @ -136 dBm	TTFF <sub>TYP</sub>	-	0.5	-	s
Hot Start – Low Signal @ - 141 dBm	TTFF <sub>LOW</sub>	-	0.8	-	s
Hot Start – Weak Signal @ - 146 dBm	TTFF <sub>WEAK</sub>	-	1.9	-	s
Cold Start @ -136 dBm	TTFF <sub>CLD</sub>	-	38	-	s
Reacquisition @ -136 dBm	TTFF <sub>RACQ</sub>	-	0.1	-	s

**Notes:**

<sup>1</sup> Stationary receiver, unless otherwise specified.

<sup>2</sup> All parameters are at TA = 25C°, unless otherwise specified.

#### 3.5.2 Position Accuracy (3-D NAV)

Table 5 below presents the Positional Accuracy for the W2SG0006 when integrated with the W2SG0006-DEV Development System.

**Table 5: Positional Accuracy**

Parameter <sup>1</sup>	Typ.	Units
Horizontal Position Accuracy: CEP (50%)	3	m
Horizontal Position Accuracy: 2dRMS (95%)	5	m
Vertical Position Accuracy: CEP (50%)	3	m
Vertical Position Accuracy: 2dRMS (95%)	5	m
Horizontal Velocity Accuracy: Deviation	0.728	m/s
Vertical Velocity Accuracy: Deviation	0.379	m/s

**Notes:**

<sup>1</sup> Stationary receiver, Open Sky at -130dBm, unless otherwise specified.

<sup>2</sup> All parameters are at TA = 25C°, unless otherwise specified.

### 3.6 Environmental Characteristics

Table 6 establishes the environmental limits for operational use of the W2SG0006.

**Table 6: Environmental Characteristics**

Parameter	Symbol	Min	Typ.	Max.	Units
Storage Temperature	T <sub>STR</sub>	-40	-	+85	C°
Operating Temperature	T <sub>OPR</sub>	-30	+25	+85	C°
Humidity		5	-	95	%/Non-condensing
Altitude		-	-	60,000/18,288	ft/m
Acceleration		-	-	6.0	g

### 3.7 Antenna

The W2SG0006 provides a 50 Ohm antenna launch (pin 22) for connection to either a passive or active antenna. The GPS module includes an internal LNA is designed to work with the passive antenna, but provides the bias voltage supply for an active antenna to improve the receive sensitivity. If the design is to work with an Active Antenna; Pin 21 (VCC\_ANT) is tied to 3.3VDC.

### 3.8 Normal Operation Implementation

Under normal operation with a passive antenna the W2SG0006 requires no external active components. Figure 3 illustrates the normal implementation for a module with external host.

**Figure 3: Normal Operation Implementation**

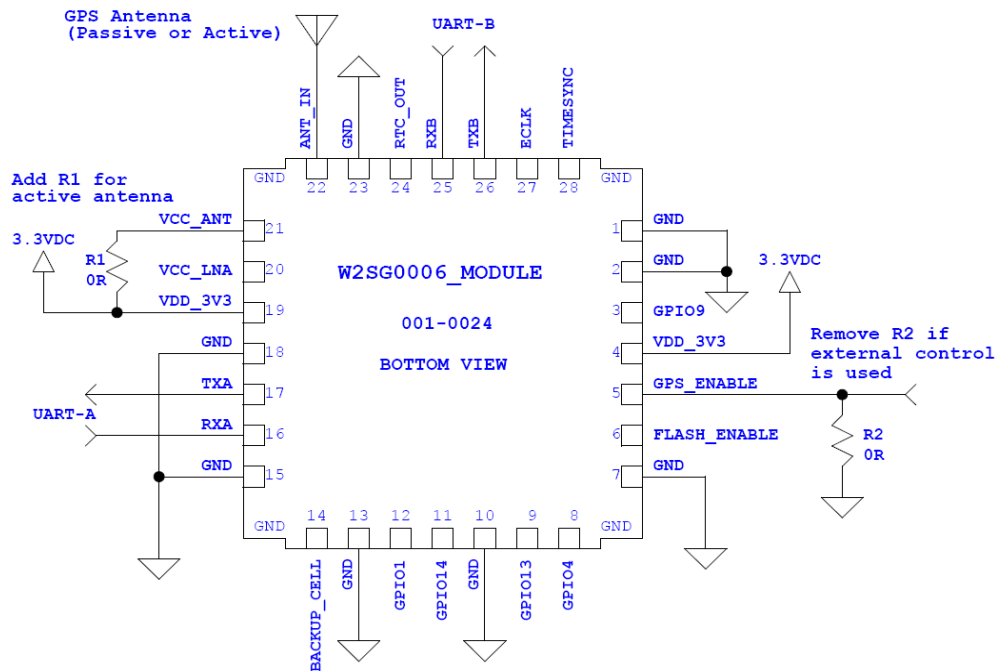

### 3.9 Backup Cell and Main Battery Implementation

The W2SG0006 provides backup-cell option to the user. Figure 4 shows recommended connections for backup cell (pin #14) and main battery (pin #4). The minimum voltage for the backup-cell pin is 2.0V.

Figure 4: Battery and Backup Cell Connections

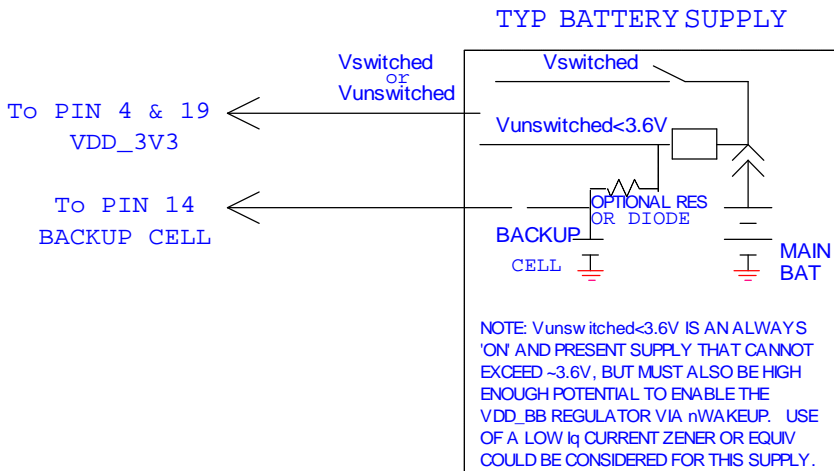

### 3.10 Flash Enable/Firmware Upgrade Implementation

The W2SG0006 Firmware is capable of being programmed or upgraded via the UART port A (Pins 16 and 17). Please note that this cannot be accomplished from UART port B. This is accomplished using the SiRFFlash™ tool available to SiRF licensed developers. To enable the module to be programmed, 3.3VDC must be applied to the FLASH\_ENABLE (Pin 6). Figure 5 illustrates Flash Enable/Firmware upgrade implementation. Note: The W2SG0006 will not operate as a GPS receiver while 3.3VDC is applied to the FLASH\_ENABLE pin.

Figure 5: Flash Enabling for Programming

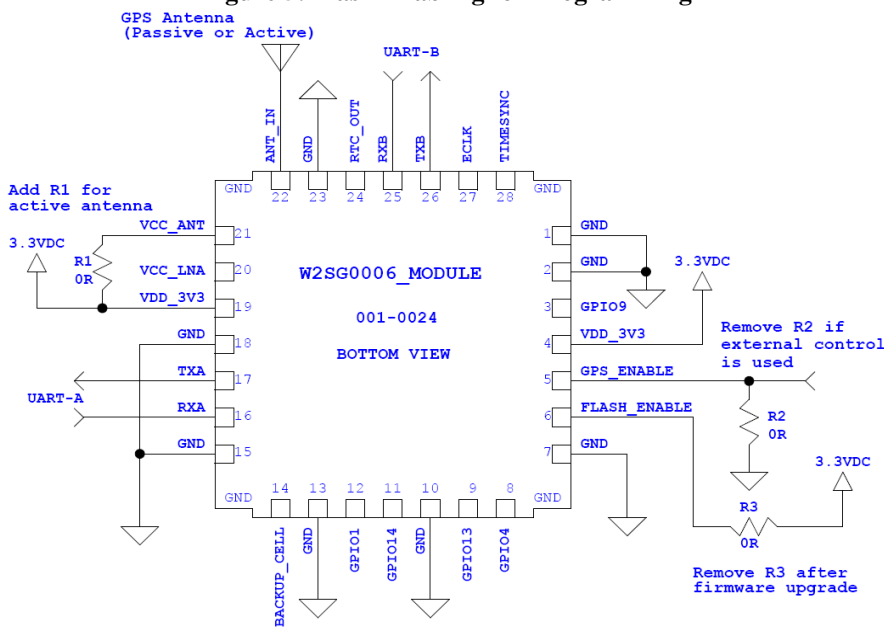

## 4 Development Support

The W2SG0006 device is embedded with GPS software, GSW3. This software is optimized to work in very weak signal environments to improve navigation availability and accuracy.

To enable GPS performance testing, Wi2Wi provides a W2SG0006 GPS Evaluation board, along with the SiRFDemo software tools.

The SiRFDemo is a PC tool that provides real-time monitoring of an attached GPS receiver's operation such as satellites being tracked, observed signal strength, and current position. It also provides the ability to configure the receiver for specific operating modes, as well as a data logging ability for later investigation.

## 5 NMEA Input and Output Messages

### 5.1 NMEA Output Messages

The NMEA output commands generated by the W2SG0006 are listed in Table 7. Please note that messages 152 and 154 are generated when Extended Ephemeris is enabled (in the default firmware, this feature is disabled).

**Table 7: NMEA Output Messages**

Message	Description
GGA	Time, position and fix type data.
GLL	Latitude, longitude, UTC time of position fix and status.
GSA	GPS receiver operating mode, satellites used in the position solution, and DOP values.
GSV	The number of GPS satellites in view satellite ID numbers, elevation, azimuth, and SNR values.
MSS	Signal-to-noise ratio, signal strength, frequency, and bit rate from a radio-beacon receiver.
RMC	Time, date, position, course and speed data.
VTG	Course and speed information relative to the ground.
152	Extended Ephemeris Integrity
154	Extended Ephemeris ACK

## 5.2 NMEA Input Messages

The NMEA messages used to control the W2SG0006 modules are listed in Table 8. Messages 100 to 106 are SiRF proprietary NMEA messages. The MSK NMEA string is as defined by the NMEA 0183 standard.

**Table 8: NMEA Input Messages**

Message	Message ID	Description
SetSerialPort	100	Set PORT A parameters and protocol
NavigationInitialization	101	Parameters required for start using X/Y/Z
SetDGPSPort	102	Set PORT B parameters for DGPS input
Query/Rate Control	103	Query standard NMEA message and/or set output rate
LLANavigationInitialization	104	Parameters required for start using Lat/Lon/Alt
Development Data On/Off	105	Development Data messages On/Off
Select Datum	106	Selection of datum to be used for coordinate transformations
Extended Ephemeris Proprietary 1	107	Extended Ephemeris Proprietary message
Extended Ephemeris Proprietary 2	108	Extended Ephemeris Proprietary message
Extended Ephemeris Debug	110	Extended Ephemeris Debug
MSK Receiver Interface	MSK	Command message to a MSK radio-beacon receiver

## 6 SiRF Binary Input and Output Messages

### 6.1 SiRF Binary Output Messages

SiRF Binary Output Messages generated by the W2SG0006 are listed in Table 9. Please note that the support of individual commands is dependent upon the firmware loaded in the module.

**Table 9: SiRF Binary Output Messages**

Hex	Decimal	Name	Description
01	1	Reference Navigation Data	Not Implemented
02	2	Measured Navigation Data	Position, velocity, and time
03	3	True Tracker Data	Not Implemented
04	4	Measured Tracking Data	Satellite and C/No information
05	5	Raw Track Data	Not supported by SiRFstarII
06	6	SW Version	Receiver software
07	7	Clock Status	Current clock status
08	8	50 BPS Subframe Data	Standard ICD format
09	9	Throughput	Navigation complete data
0A	10	Error ID	Error coding for message failure
0B	11	Command Acknowledgment	Successful request
0C	12	Command NAcknowledgment	Unsuccessful request
0D	13	Visible List	Auto Output
0E	14	Almanac Data	Response to poll
0F	15	Ephemeris Data	Response to poll
10	16	Test Mode 1	For use with SiRFtest (Test Mode 1)
11	17	Differential Corrections	Received from DGPS broadcast
12	18	OkToSend	CPU ON / OFF (TricklePower)
13	19	Navigation Parameters	Response to Poll
14	20	Test Mode 2/3/4	Test Mode 2, 3, or 4 test data
1B	27	DGPS Status	Differential GPS status information
1C	28	Nav. Lib. Measurement Data	Measurement data
1D	29	Nav. Lib. DGPS Data	Differential GPS data
1E	30	Nav. Lib. SV State Data	Satellite state data
1F	31	Nav. Lib. Initialization Data	Initialization data
29	41	Geodetic Navigation Data	Geodetic navigation information
2B	43	Queue Command Parameters	Command parameters
2D	45	Raw DR Data	Raw DR data from ADC
2E	46	Test Mode 3	Additional test data (Test Mode 3)
30	48	Test Mode 4 for SiRFLoc v2.x only	Additional test data (Test Mode 4)
30	48	SiRFDrive-specific Class of Output Messages	The MID is partitioned into messages identified by Sub IDs
31	49	Test Mode 4 for SiRFLoc v2.x only	Additional test data (Test Mode 4)
32	50	SBAS Parameters	SBAS operating parameters
34	52	1 PPS Time Message	Time message for 1 PPS
37	55	Test Mode 4	Track Data
38	56	Extended Ephemeris Data	Extended Ephemeris Mask and Integrity Information
E1	225	SiRF internal message	Reserved
FF	255	Development Data	Various status messages

## 6.2 SiRF Binary Input Messages

SiRF Binary input commands for the W2SG0006 are listed in Table 10. Please note that the support of individual commands is dependent upon the firmware loaded in the module.

**Table 10: SiRF Binary Input Messages**

Hex	Decimal	Name	Description
35	53	Advanced Power Management	Power management scheme for SiRFLoc and SiRFXTrac
80	128	Initialize Data Source	Receiver initialization and associated parameters
81	129	Switch to NMEA Protocol	Enable NMEA messages, output rate and baud rate
82	130	Set Almanac (upload)	Sends an existing almanac file to the receiver
83	131	Handle Formatted Dump Data	Outputs formatted data
84	132	Poll Software Version	Polls for the loaded software version
85	133	DGPS Source Control	DGPS correction source and beacon receiver information
86	134	Set Binary Serial Port	Baud rate, data bits, stop bits, and parity
88	136	Mode Control	Navigation mode configuration
89	137	DOP Mask Control	DOP mask selection and parameters
8A	138	DGPS Mode	DGPS mode selection and timeout value
8B	139	Elevation Mask	Elevation tracking and navigation masks
8C	140	Power Mask	Power tracking and navigation masks
8F	143	Static Navigation	Configuration for static operation
90	144	Poll Clock Status	Polls the clock status
91	145	Set DGPS Serial Port	DGPS port baud rate, data bits, stop bits, and parity
92	146	Poll Almanac	Polls for almanac data
93	147	Poll Ephemeris	Polls for ephemeris data
94	148	Flash Update	On the fly software update
95	149	Set Ephemeris (upload)	Sends an existing ephemeris to the receiver
96	150	Switch Operating Mode	Test mode selection, SV ID, and period.
97	151	Set TricklePower Parameters	Push to fix mode, duty cycle, and on time
98	152	Poll Navigation Parameters	Polls for the current navigation parameters
A5	165	Set UART Configuration	Protocol selection, baud rate, data bits, stop bits, and parity
A6	166	Set Message Rate	SiRF Binary message output rate
A7	167	Set Low Power Acquisition Parameters	Low power configuration parameters
A8	168	Poll Command Parameters	Poll for parameters:
			0x80: Receiver initialized & associated params
			0x85: DGPS source and beacon receiver info
			0x88: Navigation mode configuration
			0x89: DOP mask selection and parameters
			0x8A: DGPS mode selection and timeout values
			0x8B: Elevation tracking and navigation masks
			0x8C: Power tracking and navigation masks
			0x8F: Static navigation configuration
			0x97: Low power parameters
AA	170	Set SBAS Parameters	SBAS configuration parameters
AC	172	SiRFDRIve-specific Class of Input Messages	The MID is partitioned into messages identified by Sub IDs.
B4-C7	180-199	MID_UserInputBegin - MID_UserInputEnd	SDK user input messages only.
B4	180	Marketing Software Configuration	Selection of the Marketing Software Configurations as defined in bits [3:2] of the GSC2xr chip configuration register
B6	182	Set UART Configuration	Obsolete.
E4	228	SiRF internal message	Reserved
E8	232	Extended Ephemeris Proprietary	Extended Ephemeris and Debug Flag

## 7 Mechanical Information

### 7.1 Mechanical Specification

The module is a Surface Mount Device (SMD). Table 11 presents the mechanical characteristics of the W2SG0006.

**Table 11: Mechanical Characteristics**

Parameter	Specification	Tol.	Units
Size	15.15 x 15.5 x 2.5	±0.1	mm
Pad Pitch	1.5	±0.05	mm

Please refer to Section Figure 7 for the recommended mounting board pad layout

### 7.2 Outline Drawing

The overall dimensions of the W2SG0006 are 15mm x 15mm x 2.5mm. The module includes a shield.

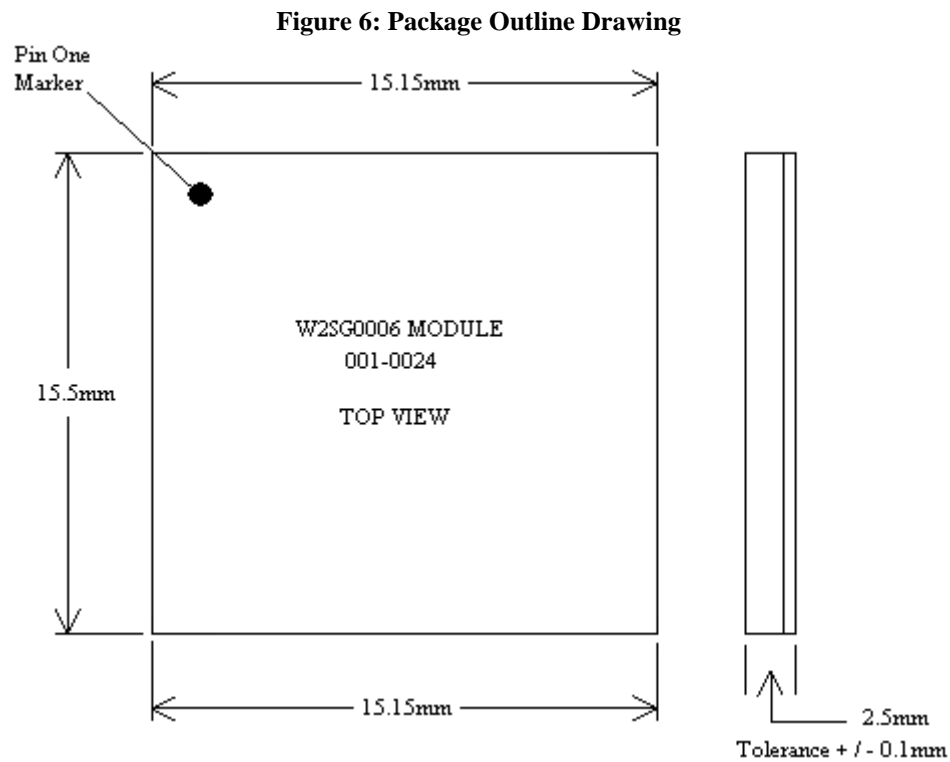

### 7.3 Recommended PCB Layout

The recommended pad pattern for the mounting board is presented in Figure 7.

**Figure 7: Recommended PCB Layout**

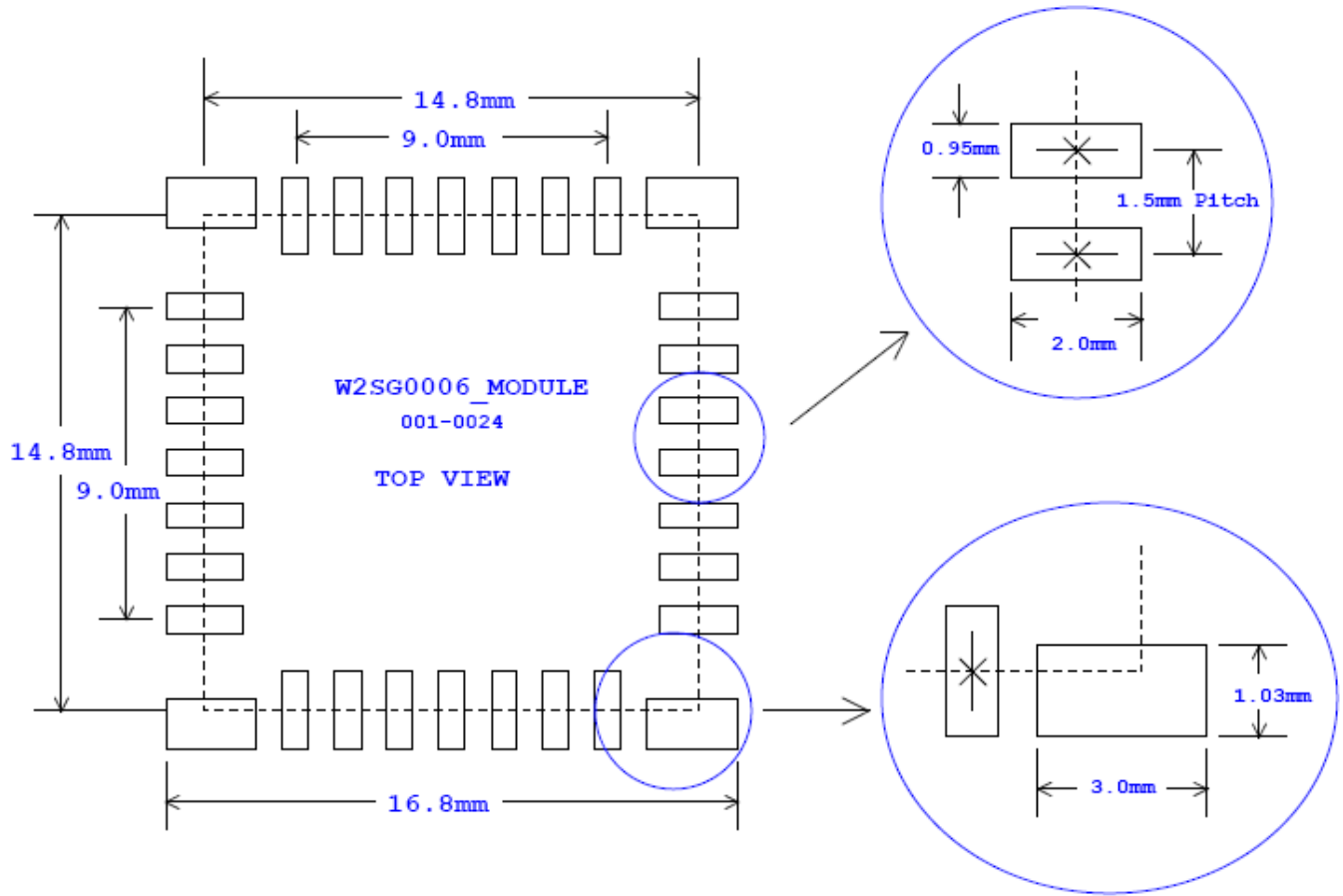

## 7.4 Recommended Reflow Profile

The W2SG0006 is a RoHS compliant product and requires a Lead-Free, RoHS compliant solder paste for proper manufacturing. The recommended reflow profile for the W2SG0006 is presented in Figure 8.

Figure 8: Recommended Reflow Profile

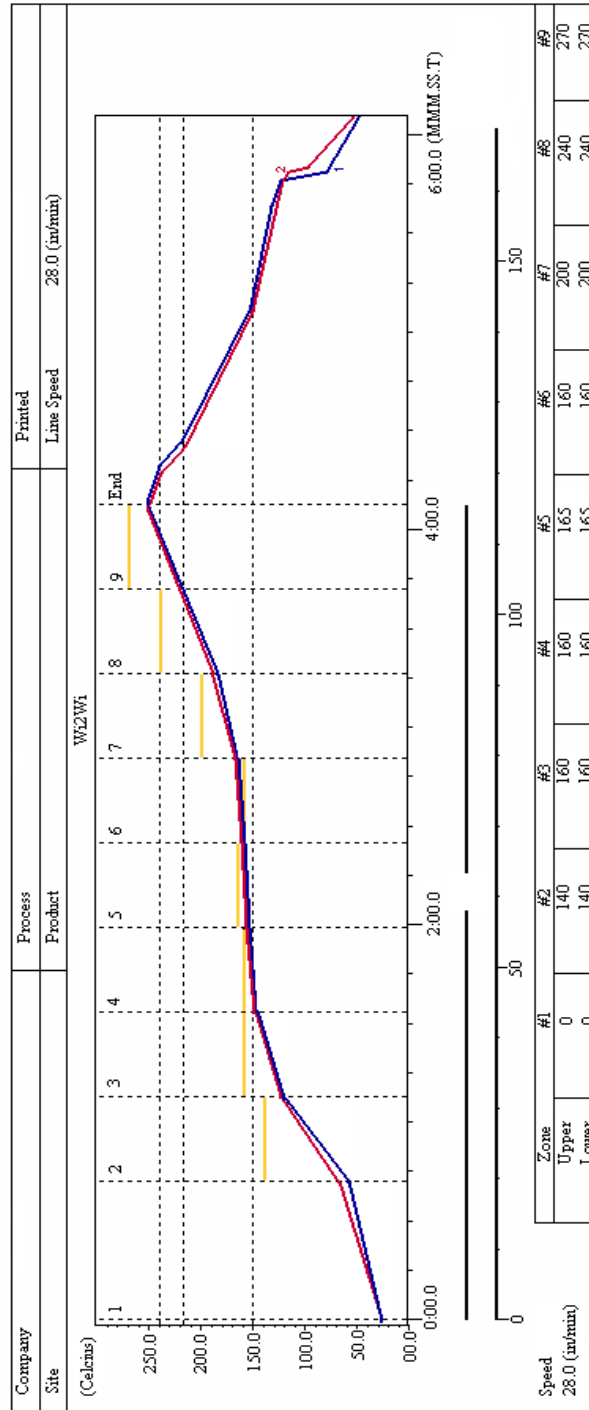

# Recommended Reflow Profile

## 8 Disclaimers

Wi2Wi, Inc. PRODUCTS ARE NOT AUTHORISED FOR USE AS CRITICAL COMPONENTS IN LIFE SUPPORT DEVICES OR SYSTEMS WITHOUT THE EXPRESS WRITTEN APPROVAL OF THE MANAGING DIRECTOR OF Wi2Wi, Inc.

The definitions used herein are:

a) Life support devices or systems are devices which (1) are intended for surgical implant into the body, or (2) support or sustain life and whose failure to perform when properly used in accordance with the instructions for use provided in the labeling can reasonably be expected to result in a significant injury to the user. b) A critical component is any component of a life support device or system whose failure to perform can be reasonably expected to cause the failure of the life support device or system, or to affect its safety or effectiveness.

Wi2Wi does not assume responsibility for use of any of the circuitry described, no circuit patent licenses are implied and Wi2Wi reserves the right at any time to change without notice said circuitry and specifications.

## 8.1 Data Sheet Status

Wi2Wi, Inc. reserves the right to change the specification without prior notice in order to improve the design and supply the best possible product. Updated information, firmware and release notes will be made available on [www.wi2wi.com](http://www.wi2wi.com). Please check with Wi2Wi Inc. for the most recent data before initiating or completing a design.

## 9 Firmware Settings

The following are the default settings in the firmware:

- Communication protocol on UART port A: NMEA
- Communication protocol on UART port B: SiRF Binary
- Baud rate on UART port A: 9600 bps
- Baud rate on UART port B: 57600 bps
- Data update rate: 1Hz
- Static navigation is enabled (suitable for navigation systems)

## 10 Part Numbering

The following part numbering scheme is used for the W2SG0006:

- Part with default firmware settings as specified in Section 8 of this document: W2SG0006
- Part with custom firmware settings: W2SG0006-XXX, where XXX denote the firmware version (e.g. 001, 002)

Wi2Wi can create custom firmware based on the requirements of the customer.

## 11 Certifications

The W2SG0006 shall conform to the following standards when integrated to the W2SG0006-DEV development system.

EMC/Immunity

- United States: FCC Part 15
- Canada: ICES 033

- European Union: EN 55022, IEC 1004/CISPR 22
- Japan: VCCI - V series
- Australia New Zealand :CISPR
- Taiwan: CNS 13438
- Korea: RRL No. 2005-82 (MIC)
- People's Republic of China: GB9254

#### Product Safety

- United States/Canada: UL/CSA 60950, UL 61010, UL 60065, CSA 601,CSA 61010,C22.2 No. 225
- European Union: EN 60950, EN61010, IEC 60065, IEC 60601
- Japan: ARIB STD-T66
- People's Republic of China: CNCA-08C-0312001
- Restriction of Hazardous Substances Directive (RoHS) 2002/95/EC

All the certification documents and declarations can be provided upon request.

## 12 References

### 12.1 Specifications

- System Specification, ICD-GPS-200C, NAVSTAR L1, Dated 12 April 2000
- NMEA 0183 Version 3.01, January 2002, Addendum NMEA 0183-HS Version 1.0
- FAA WAAS Specification FAA-E 2892b

### 12.2 Trademarks, Patents and Licenses

- Trademarks: SiRF, SiRF logo, SiRFstar, SiRF Powered, SnapLock, Foliage Lock, TricklePower, SingleSat, SiRFLoc, SiRFDrive, SnapStart, Push-to-Fix, SiRFNav, SiRFWare and WinSiRF are trademarks of SiRF Technology, Inc.
- Licenses: Software and firmware license from SiRF

### 12.3 Other

- W2SG0006-DEV      Development Kit, GPS Module