

CLOUDSPLITTER* Cable Plug Connectors

NOTE

All numerical values are in metric units [with U.S. customary units in brackets]. Dimensions are in millimeters [and inches]. Unless otherwise specified, dimensions have a tolerance of ± 0.13 [$\pm .005$] and angles have a tolerance of $\pm 2^\circ$. Figures and illustrations are for identification only and are not drawn to scale.

1. INTRODUCTION

This specification covers the requirements for application of CLOUDSPLITTER cable plug connectors for voice and data applications. The plug connector is supplied as a kit that contains of a housing, load bar, plug connector shield, ferrule, strain relief boot, and 2 micro MATE-N-LOK* power receptacle contacts. The plug connector is available for shielded cable and unshielded cable.

The housing contains 8 signal contacts on 1.02 [.040] centerline spacing with 8 signal positions and 2 power positions. The load bar is used to organize the cable signal conductors in the proper contact positions. The housing is translucent to aid in visual inspection of cable insertion and signal conductor termination and features a locking latch for securing the mating jack connector to the plug connector when mated. The plug connector shield provides continuity for electromagnetic compatibility (EMC). The strain relief boot grips the cable jacket to protect the plug connector-to-cable and contact-to-conductor interface from damage when subjected to pulling or bending forces.

When assembled, the ferrule, plug connector shield, and signal contacts are simultaneously terminated using a manual hand tool. The signal contacts are terminated using the insulation piercing technique.

NOTE

CLOUDSPLITTER cable plug connectors are intended to be used in a Category 5e system when applied in accordance with the requirements given in this document. These requirements comply with Telecommunications Industry Association and Electronic Industries Alliance (TIA/EIA) 568-5-A, "Commercial Building Telecommunications Cabling Standard".

NOTE

These products are intended for indoor use only in communications circuits in an isolated closed loop circuit and not for telecommunications circuits (POTS).

When corresponding with personnel, use the terminology provided in this specification to facilitate your inquiries for information. Basic terms and features of this product are provided in Figure 1.

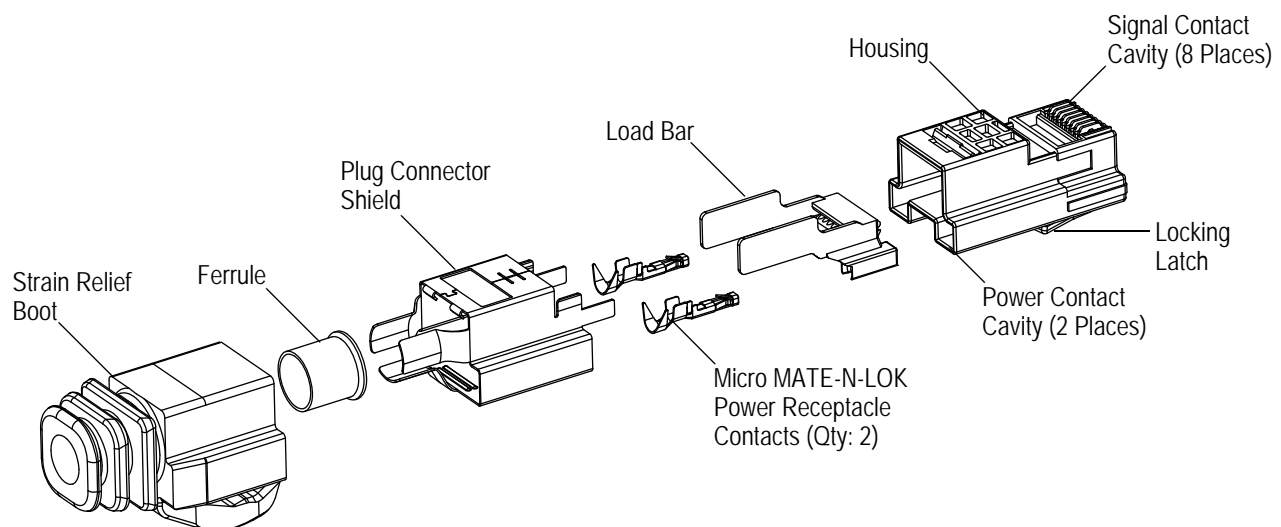

Figure 1

POTS is plain old telephone service.

2. REFERENCE MATERIAL

2.1. Revision Summary

Revisions to this application specification include:

- Indicated CLOUDSPLITTER as a trademark
- Changed reference zone dimension in Figure 8, and modified Figure 5, Details A and B, Figure 6, Details A and B, and added Detail C, and added detail to Figure 8
- Split Step 4 and modified new Step 9 of Paragraph 3.5, added new Paragraph 3.6, C, and changed Section 4

2.2. Customer Assistance

Reference Product Base Part Number 2178148 and Product Code 4149 are representative of CLOUDSPLITTER cable plug connectors. Use of these numbers will identify the product line and help you to obtain product and tooling information. Such information can be obtained through a local Representative, by visiting our website at www.te.com, or by calling PRODUCT INFORMATION or the TOOLING ASSISTANCE CENTER at the numbers at the bottom of page 1.

2.3. Drawings

Customer Drawings for product part numbers are available from the service network. If there is a conflict between the information contained in the Customer Drawings and this specification or with any other technical documentation supplied, the information contained in the Customer Drawings takes priority.

2.4. Specifications

Design Objective 108-64022 provides expected product performance and test information.

Application Specification 114-13000 provides product description and application requirements for micro MATE-N-LOK power contacts.

2.5. Instructional Material

Instruction Sheets (408-series) provide product assembly instructions or tool setup and operation procedures. Documents available which pertain to this product are:

- 408-32090 Mini Double Action Hand Tool (DAHT) 2217299-1
- 408-32098 Crimping Tool 2217400-1 for CLOUDSPLITTER Cable Plug Connectors
- 408-32100 CLOUDSPLITTER Cable Plug Connector Kits 2178148-[]

3. REQUIREMENTS

3.1. Material

The housing is made of flame retardant rated polycarbonate (UL 94-V-0). The contacts are made of phosphor bronze underplated with nickel and contact area plated with gold. The shield is made of brass plated with tin or nickel. The external strain relief is made of brass plated with tin and underplated with nickel.

3.2. Storage

A. Ultraviolet Light

Prolonged exposure to ultraviolet light may deteriorate the chemical composition used in the plug connector material.

B. Shelf Life

The plug connectors and power receptacle contacts should remain in the shipping containers until ready for use to prevent deformation to the contacts. The plug connectors should be used on a first in, first out basis to avoid storage contamination that could adversely affect performance.

3.3. Chemical Exposure

Do not store plug connectors or power receptacle contacts near any chemical listed below as they may cause stress corrosion cracking in the contacts.

Alkalies	Ammonia	Citrates	Phosphates	Citrates	Sulfur Compounds
Amines	Carbonates	Nitrites	Sulfur	Nitrites	Tartrates

3.4. Cable Selection and Preparation

A. Selection

The plug connector accepts unshielded or shielded round 10-conductor stranded copper cable with 8 signal conductors and 2 power conductors having the cable diameter and conductor size and insulation outside diameter range given in Figure 2.

The conductor maximum insulation outside diameter **MUST NOT** be exceeded.



NOTE

Other performance-rated cable meeting the construction requirements stated in this document may be used; however, they might not meet the requirements for Category 5e cable system.

CABLE					
TYPE	OUTSIDE DIAMETER RANGE	SIGNAL CONDUCTOR		POWER CONDUCTOR	
		Size (AWG)	Insulation Outside Diameter Range	Size (AWG)	Insulation Outside Diameter Range
Unshielded	6.3-6.5	26	0.70-0.79	18	1.50-2.79
Shielded	7.4-7.7		0.92-1.02		

Figure 2

B. Preparation

The cable must be prepared according to the following:

Unshielded Cable

Proper cable strip length is necessary to properly insert unshielded cable into the plug connector. The strip length is given in Figure 3.



NOTE

Reasonable care must be taken not to nick or cut the cable conductor insulation during the stripping operation.

Shielded Cable

1. A blade tip must be inserted between the shield and jacket. The jacket must be slit back from the end to the dimension given in Figure 3.



CAUTION

The conductor insulation must not be nicked.

2. The jacket must be pulled away from the shield, and folded back over the cable. The slit portion of the jacket must be cut off. Care shall be taken not to cut the shield. The conductors enclosed by the shield should extend to the dimension given in Figure 3.

3. Using the overlap in the seam, the shield must be pulled away from the conductors. Care must be taken not to damage the shield.

4. The shield and metalized polyester foil must be folded back over the cable.

5. The shield must be trimmed to the approximate length given in Figure 3.

6. The shield must be formed smoothly around the cable. The conductive surface of the shield must be exposed; if it is not, another fold must be formed.

3.5. Assembly

1. The power receptacle contacts must be crimped using the hand tool given in Section 5 and meet the requirements given in 114-13000.

2. The strain relief boot, ferrule, and plug connector shield must be installed onto the cable in the orientation shown in Figure 4.

Note: Not to Scale

Unshielded Cable

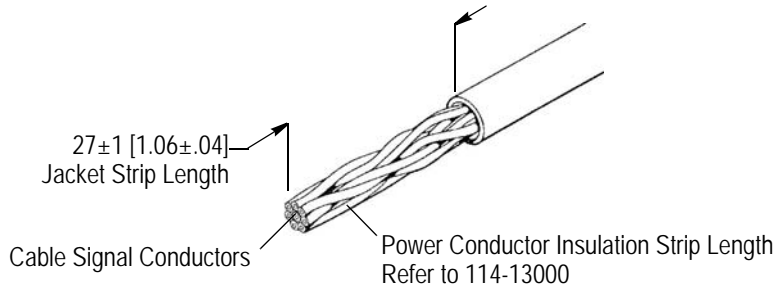

Shielded Cable

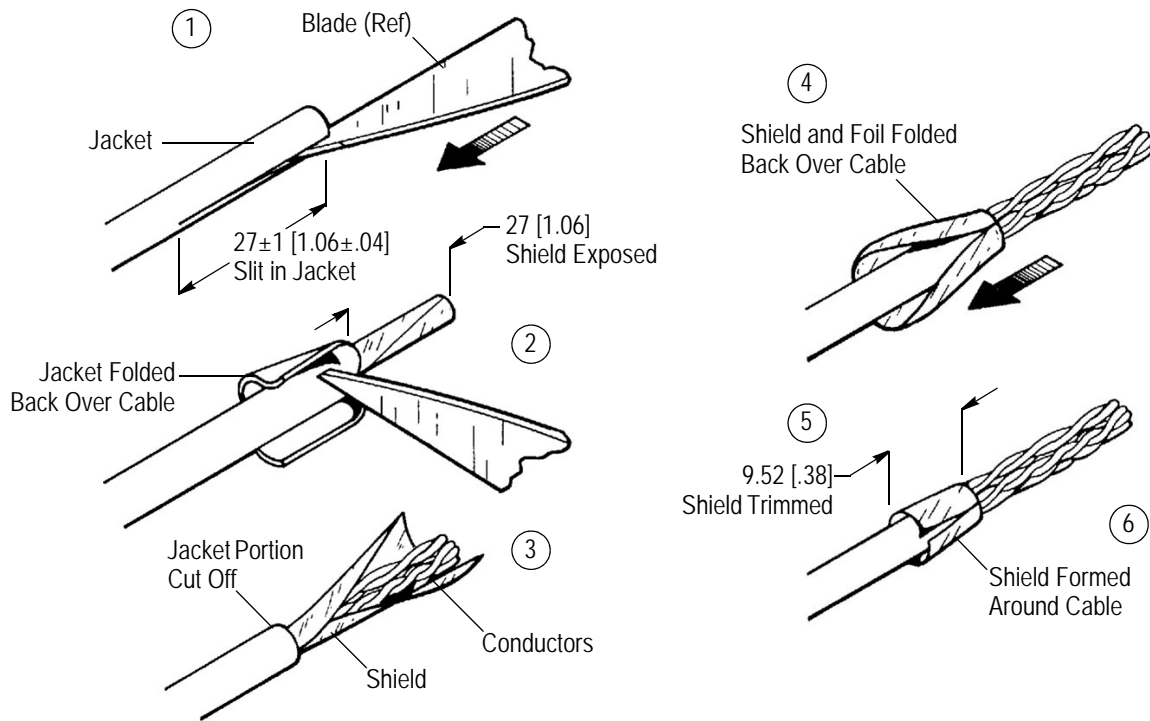

Figure 3

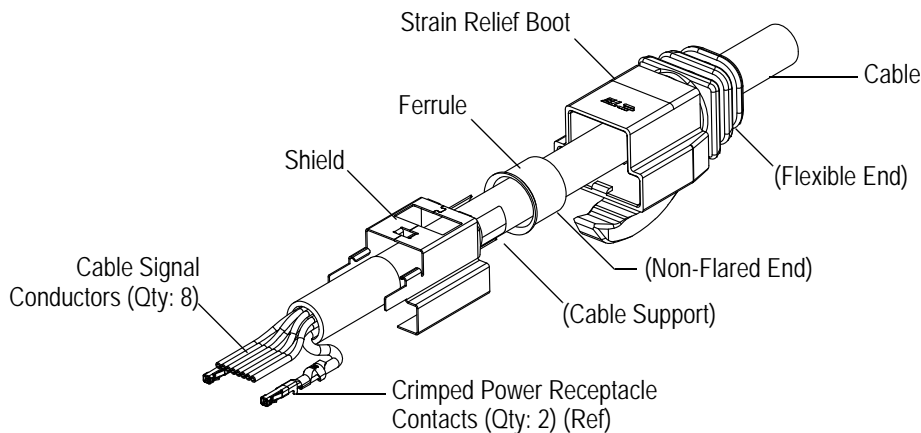

Figure 4

3. The cable signal conductors must be arranged according to the following.

- a. The conductors must be grouped in pairs according to electrical schematic T568C, and the conductor pairs must be arranged in the sequence shown in Figure 5, Detail A.
- b. While holding the end of the cable jacket, the conductor pairs must be untwisted and arranged in positions for the electrical schematic as shown in Figure 5, Detail B.



CAUTION

IT IS CRITICAL that the conductor pairs DO NOT untwist inside the cable jacket. Conductor 6 must be crossed over Conductors 4 and 5. It is extremely important that the twist for Conductor 6 be maintained as it crosses over top of Conductors 4 and 5. Refer to Figure 5, Detail C.

- c. Maintaining the proper orientation of the conductors, the conductors must be trimmed evenly — leaving a length, measured from the end of the cable jacket to the tips of the conductors, that meets the dimension given in Figure 5, Detail C.



NOTE

It is recommended to maintain twist on any conductor pair outside the cable jacket if it can be achieved with conductor pairs remaining in position for the electrical schematic.

Cable Signal Conductor Arrangement

Detail A

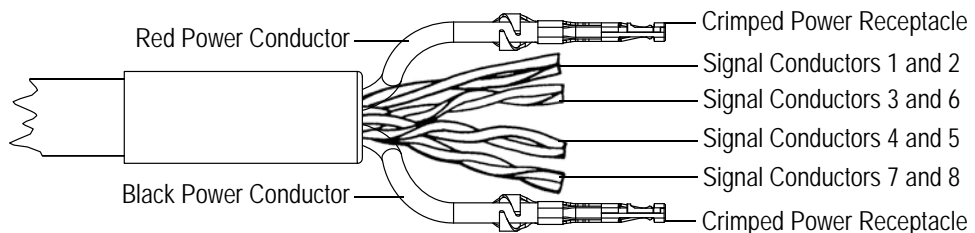

Detail B

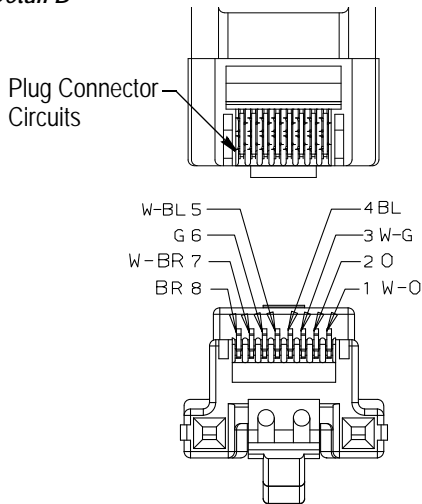

SIGNAL CONDUCTOR PAIR NUMBER	SIGNAL CONDUCTOR COLOR CODE (Abbreviation)		SIGNAL CONDUCTOR NUMBER (Electrical Schematic T568C)
	OPTION 1	OPTION 2	
1	White-Blue (W-BL)	Green (G)	5
	Blue (BL) ■	Red (R)	4
2	White-Orange (W-O)	Black (BK)	1
	Orange (O)	Yellow (Y)	2
3	White-Green (W-G)	Blue (BL)	3
	Green (G) ■	Orange (O)	6
4	White-Brown (W-BR)	Brown (BR)	7
	Brown (BR) ■	Slate (S)	8

■ A white marking is acceptable.

Detail C

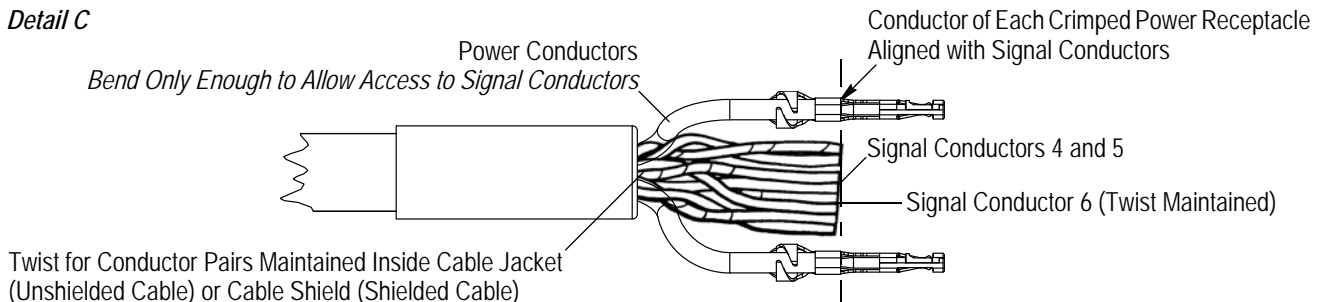

Figure 5

4. The cable signal conductors must be fully inserted into the applicable position of the load bar. See Figure 6, Detail A.

5. The crimped power receptacle contacts must be inserted into the applicable tower of the load bar. The locking lance of each power receptacle contact must be engaged with the tower. See Figure 6, Detail B.

i **NOTE**
Each cable power conductor must be dressed back over the cable jacket in order to insert the contact into the tower.

6. The space between the cable shield (shielded cable) or cable jacket (unshielded cable) and the notch of the load bar must meet the dimension given in Figure 6, Detail B.

7. The cable signal conductors must be trimmed square and even with the end of the power receptacle contacts. Refer to Figure 6, Detail B.

8. The cable must be pulled back from the load bar so that the length of the signal conductors measured from the end of the load bar to the tip of the signal conductors meets the dimension given in Figure 6, Detail C.

! **CAUTION**
The signal conductors must not extend too far from the load bar; otherwise, the load bar will twist and become deformed when installed onto the plug connector housing.

Cable Signal Conductor and Power Receptacle Contact Insertion

Detail A

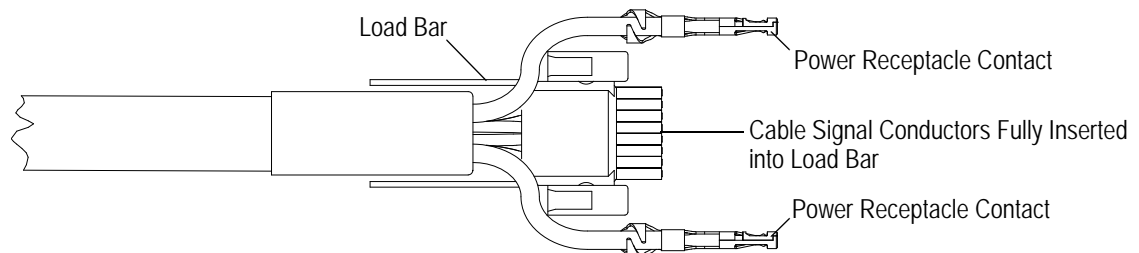
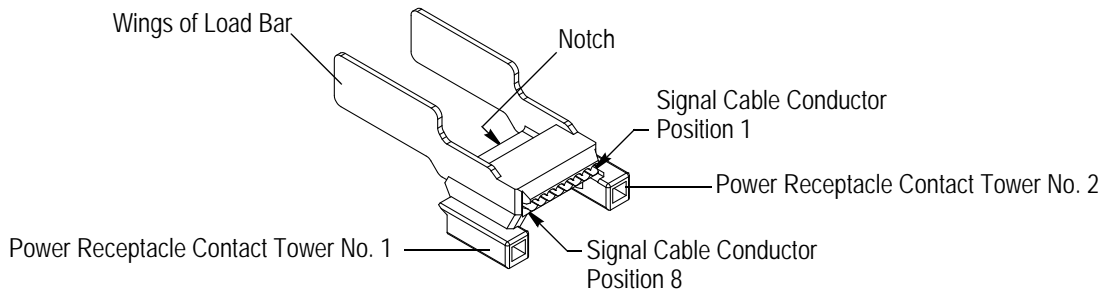

Detail B

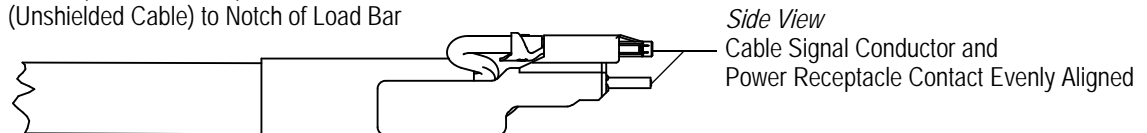
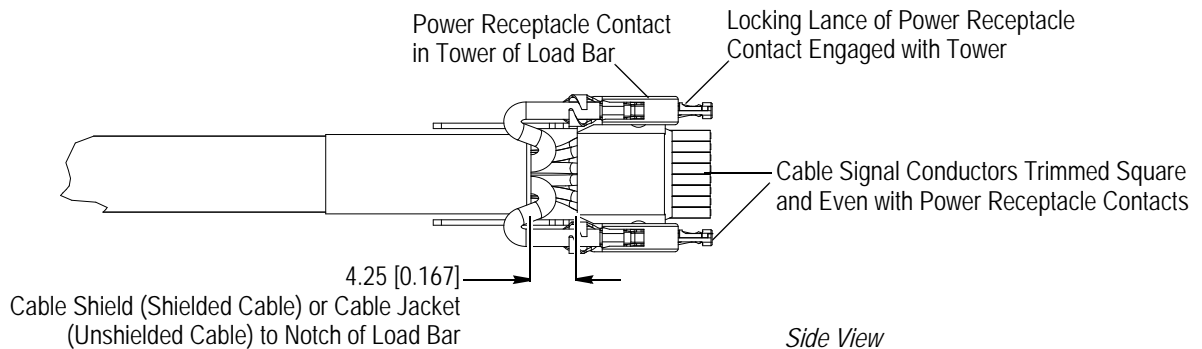

Figure 6 (Cont'd)

Detail C

Figure 6 (End)

9. The load bar must be press fit into the housing so that the wings are flush with the back of the housing. The interference fit between the load bar and housing is designed to keep these parts together. Resistance during this assembly is normal. See Figure 7, Detail A.

The signal conductors must be bottomed in the wire entry circuits and clearly visible through the front of the housing. See Figure 7, Detail B.

NOTE

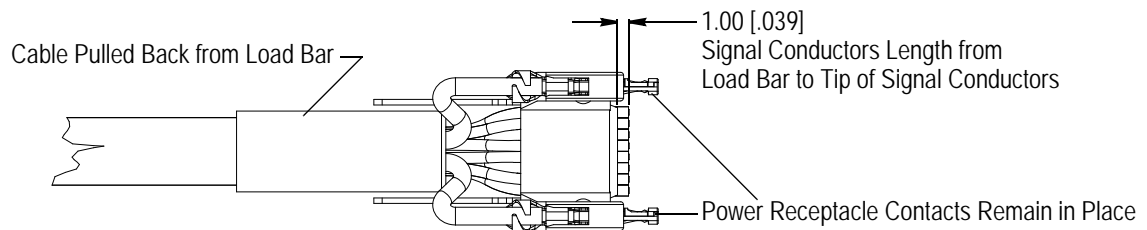
If the signal conductors are not bottomed in the wire circuits, the load bar must be removed, and the conductors re-trimmed then re-inserted. If the conductors are too short, they must be re-stripped.

10. The plug connector shield must be positioned over the housing, and the ferrule must be positioned over the cable support of the plug connector shield. Refer to Figure 7, Detail B.

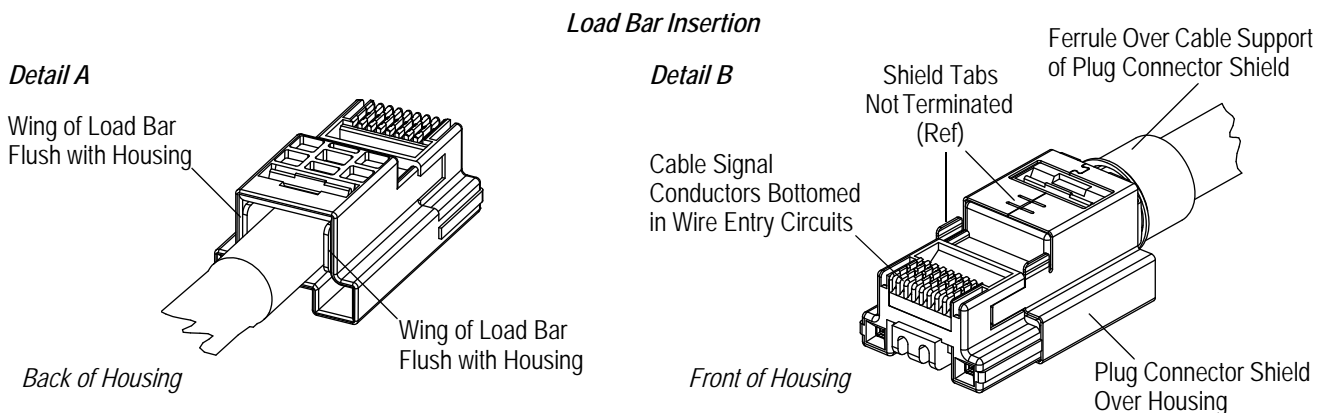

Figure 7

3.6. Termination Requirements

A. Cable Signal Conductor Location

It is preferred that all signal conductors are bottomed against the end of the wire entry circuits. If individual conductors are not completely inserted in the housing, they must be inserted at least past the signal contacts and into the reference zone to ensure a proper electrical interface. Refer to Figure 8.

B. Signal Contact Crimp Height

The crimp height of the signal contacts shall be measured from the top of the signal contact to the bottom of the housing (not including the housing locking tab) and must be within the dimension provided in Figure 8.

NOTE

All signal contacts must be at approximately the same height.

C. Power Contact Location

Each power contact must be positioned from the mating face of the cable plug connector no more than the dimension given in Figure 8.

D. Ferrule Crimp Height

The height of the ferrule, measured across the flats of the hex, must meet the dimension given in Figure 8.

E. Plug Connector Shield

The top tabs of the plug connector shield must be formed to the housing and can have a gap no larger than the dimension given in Figure 8.

The side tabs of the plug connector shield must be formed tightly to the housing within the dimensions given in Figure 8.

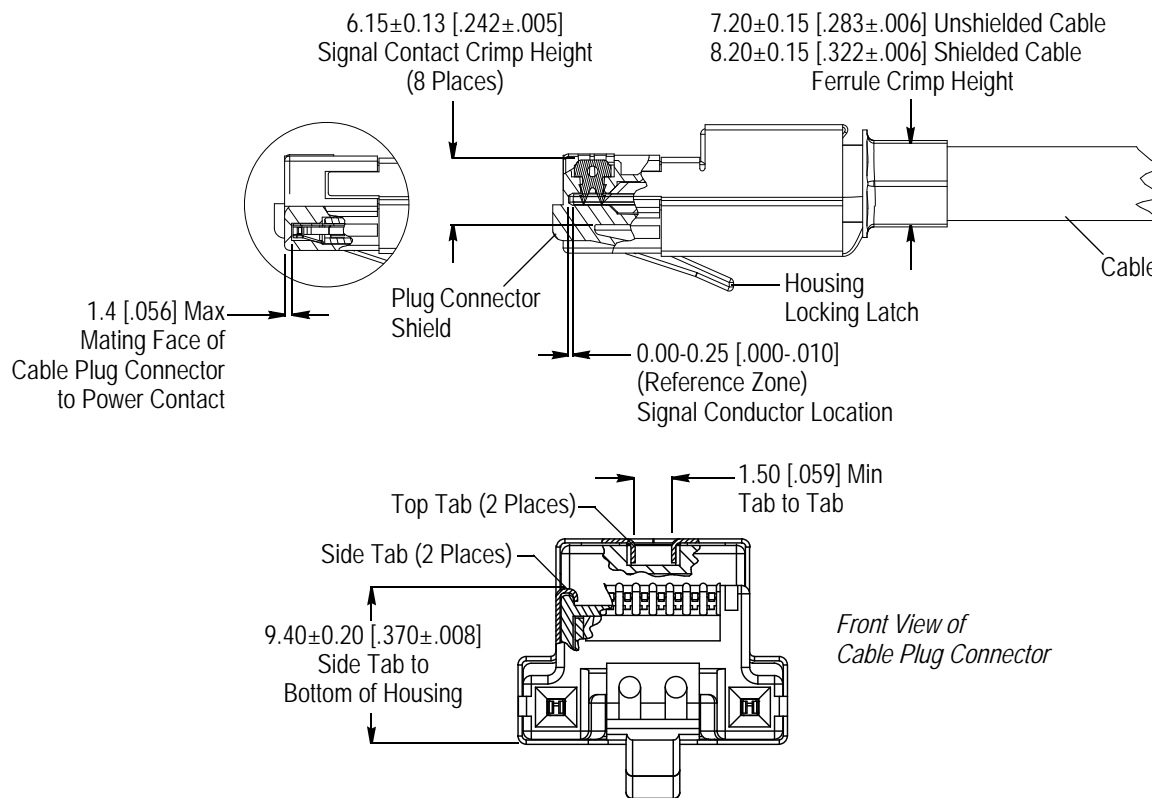

Figure 8

3.7. Installing Cable Boot

The latches of the cable boot must be engaged with the openings of the plug connector shield. The cable boot must be seated to the dimension given in Figure 9.

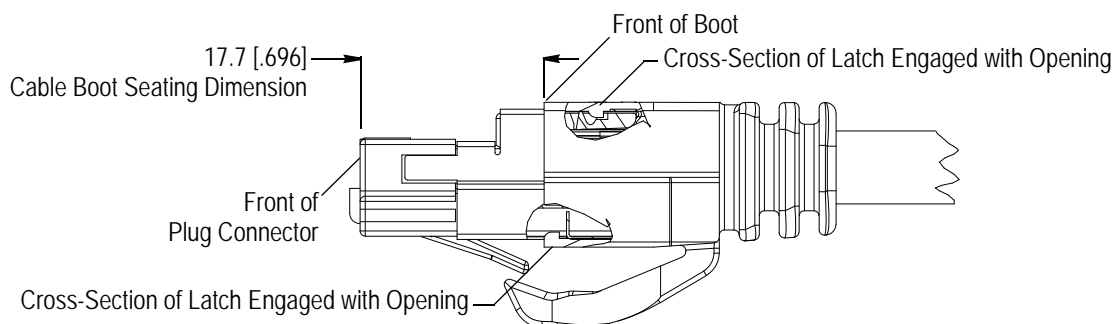

Figure 9

3.8. Mating

The plug connector must be inserted into the mating jack until it bottoms. When fully inserted, the plug connector locking latch will engage the jack connector housing and prevent the connectors from separating. The connectors will not unmate unless the plug connector locking latch is fully depressed. After mating, there will be a small amount of axial movement (travel) between the mated connectors, and with some combinations, depending on tolerance variations between original equipment manufacturers (OEM), could be up to 0.76 [.030].

3.9. Repair

These plug connectors cannot be repaired; damaged plug connectors must be removed and discarded. The cable must be cut from the plug connector and re-terminated onto a new plug connector.

4. QUALIFICATION

CLOUDSPLITTER cable plug connectors are Recognized by Underwriters Laboratories Inc. (UL) in File E81956, issued 2015-04-25, to meet US and Canadian (USR, CNR) standards.

5. TOOLING

Two hand tools must be used to terminate the cable plug connector. The mini DAHT must be used to crimp the power contacts included in this cable plug connector kit to the cable power conductors (one at a time). The crimping tool is used to terminate the shield, ferrule, and signal contacts to the cable all at once. Tool part numbers and instruction sheets are given in Figure 10.

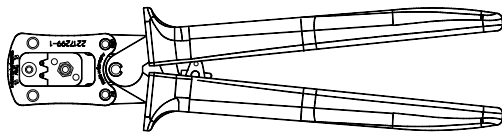

Mini Double Action Hand Tool (DAHT)
2217299-1 (408-32090)

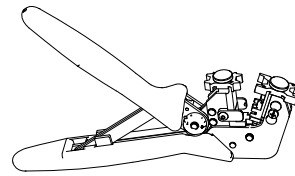

Crimping Tool 2217400-1 for CLOUDSPLITTER
Cable Plug Connectors (408-32098)

Figure 10

6. VISUAL AID

The illustration below shows a typical application of CLOUDSPLITTER cable plug connectors. This illustration should be used by production personnel to ensure a correctly applied product. Applications which DO NOT appear correct should be inspected using the information in the preceding pages of this specification and in the instructional material shipped with the product or tooling.

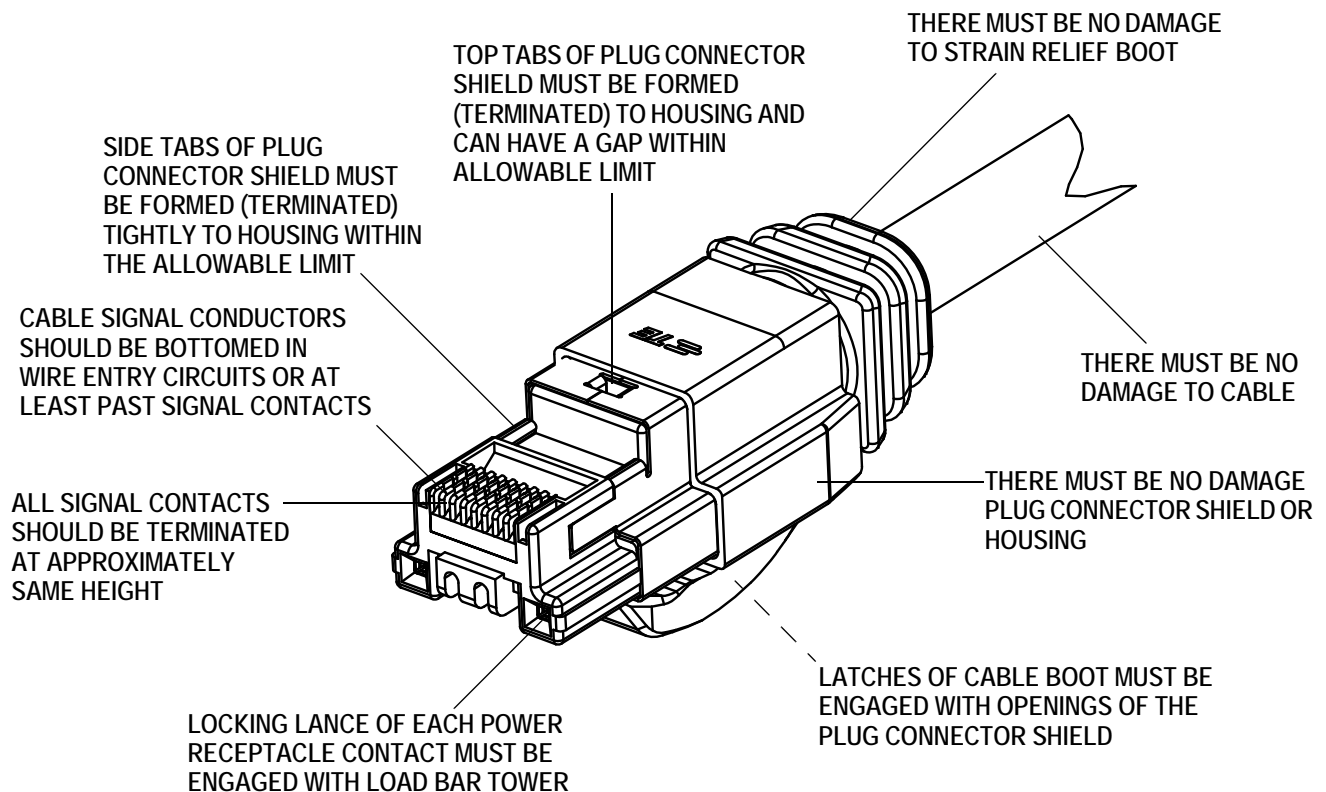

FIGURE 11. VISUAL AID