

TDK RF Products Training Module for Mouser

Jan, 2011

TDK RF Overview

Introduction to TDK RF Components and their applications



What is a BPF/LPF/Diplexer/Coupler/Balun?

BPF

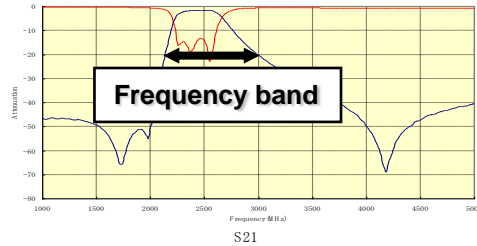

A device that passes frequencies within a certain range and rejects (attenuates) un-wanted signals.

LPF

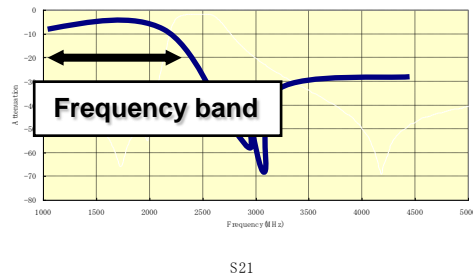

A device that allows signals below a designated frequency to pass and rejects the un-desired upper frequency signals.

Diplexer

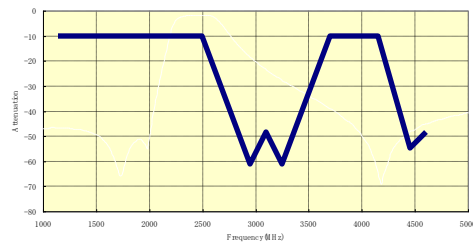

A device that Routes two different frequencies from a common port (example: One antenna port can route 2.4GHz and 5GHz signals)

Coupler

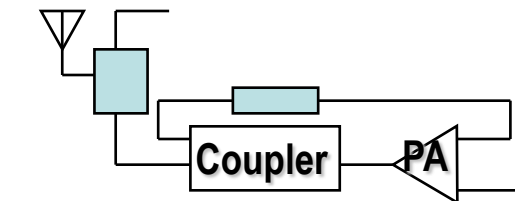

A device that is used to monitor a signal Without interrupting the signal.

Balun

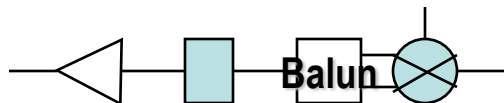

A device that converts between Balanced to Unbalanced electrical signals.

What is a BPF?

- A Band Pass Filter allows a desired frequency range to pass through while attenuating (rejecting) unwanted frequencies. For example a desired Cellular or WLAN frequency can be allowed to pass while rejecting other unwanted radio frequencies.

Operation Principal

A BPF circuit consists of Inductors and capacitors built into Dielectric ceramic creating a resonance frequency. This resonance frequency provides attenuation at certain frequencies.

Reference characteristics

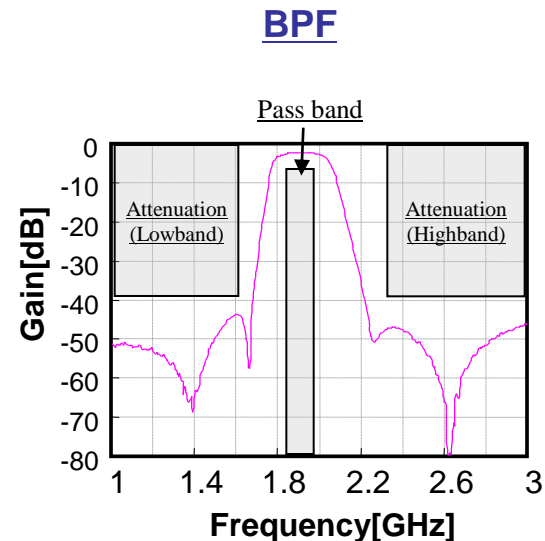

What is a LPF/HPF?

- A Low Pass Filter (LPF) allows signals below a pre-decided frequency to pass while rejecting signals above it. A High Pass Filter (HPF) is the opposite, it allow higher frequencies to pass while rejecting lower frequencies.

Operation Principal

A LPF/HPF consists of a circuit of Inductors (L) and capacitors (C) built into Dielectric ceramic. When the L and C's are connected in parallel, the resulting high impedance created rejects signals at the resonant frequency. When the L and C's are connected in serial, the resulting low impedance created allows signals to pass at the resonant frequency range. These combinations of inductors and capacitors create the HPF or LPF.

Reference characteristics

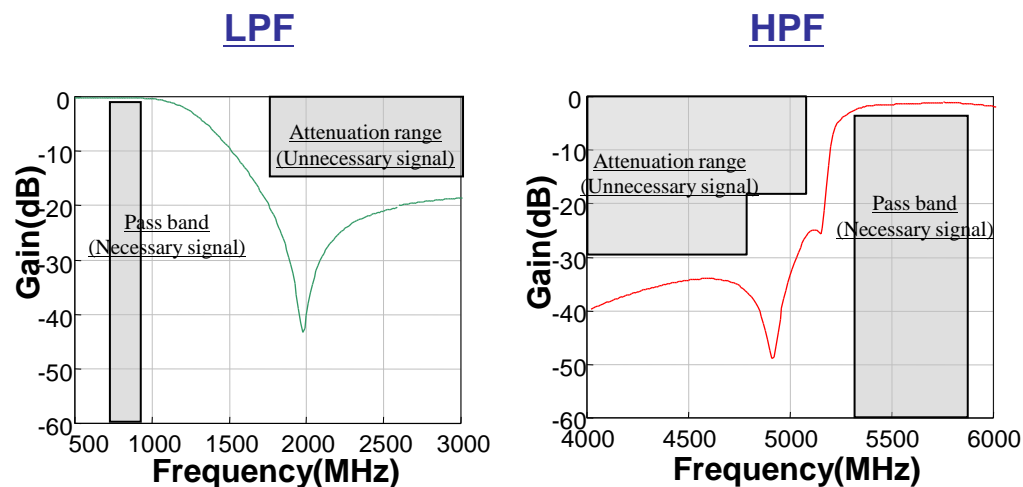

What is a Diplexer?

- Diplexers are 3-port filters that divide two frequencies from a common port. A Typical application is a diplexer for WLAN, this diplexer receives the WLAN signal from the antenna port and directs the signal to either the High band (5GHz) or the Low band (2.4GHz).

Basic concept

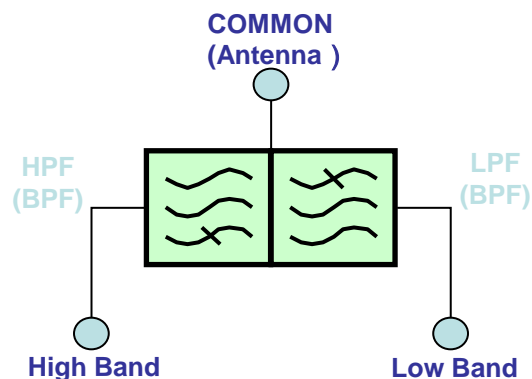

Operation Principal

A diplexer is a combination of a LPF or BPF at the low band and a HPF or BPF at the high band.

Reference characteristics

Low band

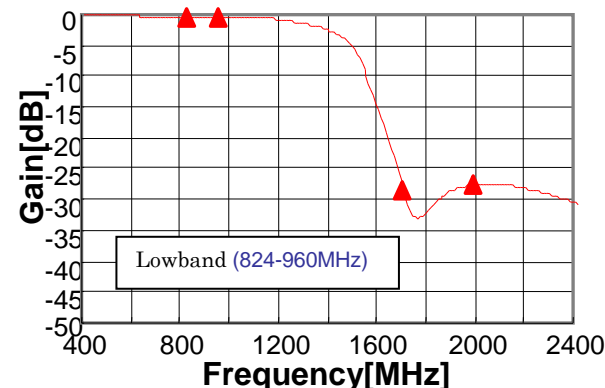

High band

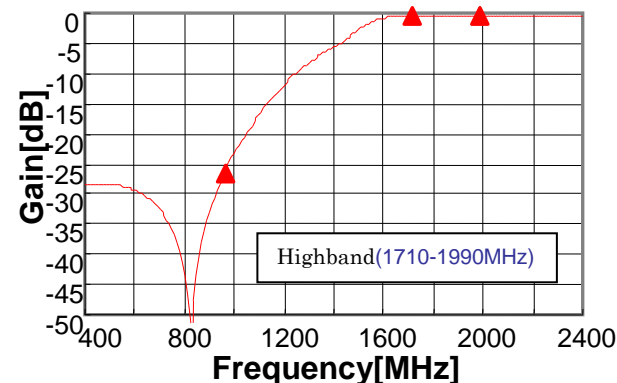

What is a Balun?

- A balun transformer converts an unbalanced signal into a balanced signal or a balanced signal into an unbalanced signal. A balun can also provide an impedance matching function. In a WLAN system a balun is used on the transmit signal path between the RF-IC (Balanced signal) and the Power Amplifier (Unbalanced signal). The balun performs as a balanced to unbalanced signal transformer and an Impedance matching transformer.

Equivalent Circuit

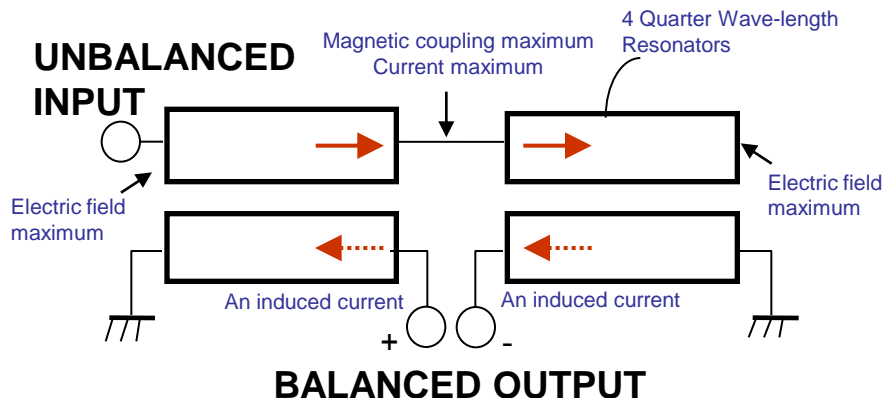

Operation Principal

A balun circuit is created by coupling two pairs of $\lambda/4$ resonators each with a unique operating frequency wavelength. A balanced signal is produced by coupling resonators of equal size and its phase reversed 180 degrees. The impedance is adjusted by a combination of the pattern width and distance within the balun.

What is a Coupler?

- Also known as a Directional Coupler. This device is used to monitor information on a signal (Ex. Frequency, power level) without interrupting the main system power path. In a WLAN system a coupler is sometimes used to monitor the output signal and control the PA output.

Equivalent Circuit

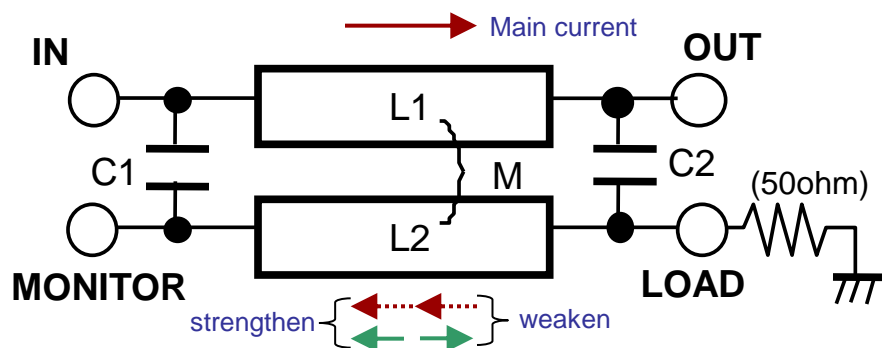

Operation Principal

Basically, a coupler function has a combination of two inductor and capacitors existing in near proximity that the power is coupled from one signal line to another.

The example of practical use

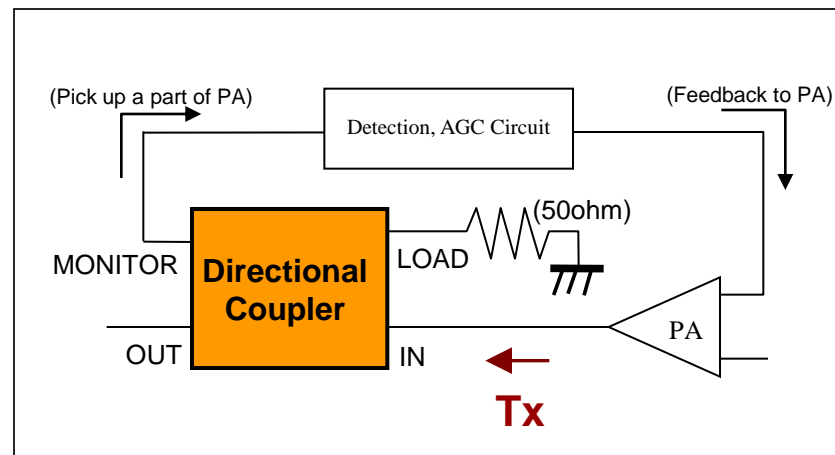

What is an antenna?

- An Antenna is a component used for receiving or transmitting Electro-magnetic waves. An antenna converts an electrical current into an electron-magnetic wave or vice versa. An antenna radiates an electromagnetic field (wave) in response to applying a voltage and current. Each wavelength has a specific frequency and wavelength (the length of an electric wave). The wavelength is inverse proportion to the value of frequency. The size of an antenna is based on this wavelength. Usually an antenna is a $\frac{1}{2}$ or $\frac{1}{4}$ wavelength.

Antenna Radiation Patterns

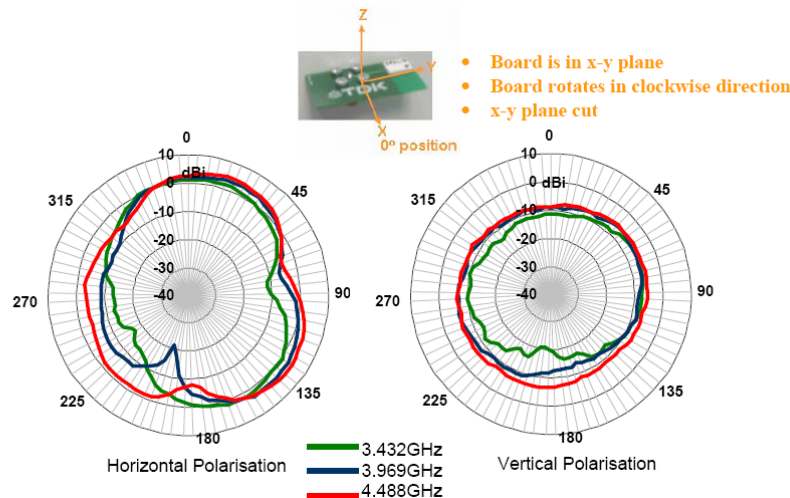

RF Components for Wireless Local Area Network (WLAN)

- What is 802.11a/b/g/n

Protocol	Release Date	Op. Freq.	Data Rate	Range (Indoor)	Range (Outdoor) *include one wall
802.11a	1999	5GHz	54Mbit/s	- 35 meters	- 120 meters
802.11b	1999	2.4GHz	11Mbit/s	-38 meters	-140 meters
802.11g	2003	2.4GHz	54Mbit/s	-38 meters	-140 meters
802.11n	2009	2.4GHz 5GHz	248Mbit/s	-70 meters	-250 meters

- 802.11a/b/g/n refer to the WLAN standards created by the IEEE (Institute of Electrical and Electronics Engineers, Inc.). These WLAN standards are used to create interoperable WLAN products.
- The original WLAN products were 802.11b followed by 802.11a.
- The most popular WLAN products today are 802.11g which use the same frequency (2.4GHz) and are backward compatible to 802.11b products.
- 802.11n is the next proposed standard. This uses a Multiple Input/Multiple Output (MIMO) technology. 802.11n products can work in either 2.4GHz or 5GHz
- TDK has components for use in 2.4GHz and 5GHz WLAN systems

RF Components for WLAN

- Block Diagram (*IEEE802.11a/b/g Dual Band*)

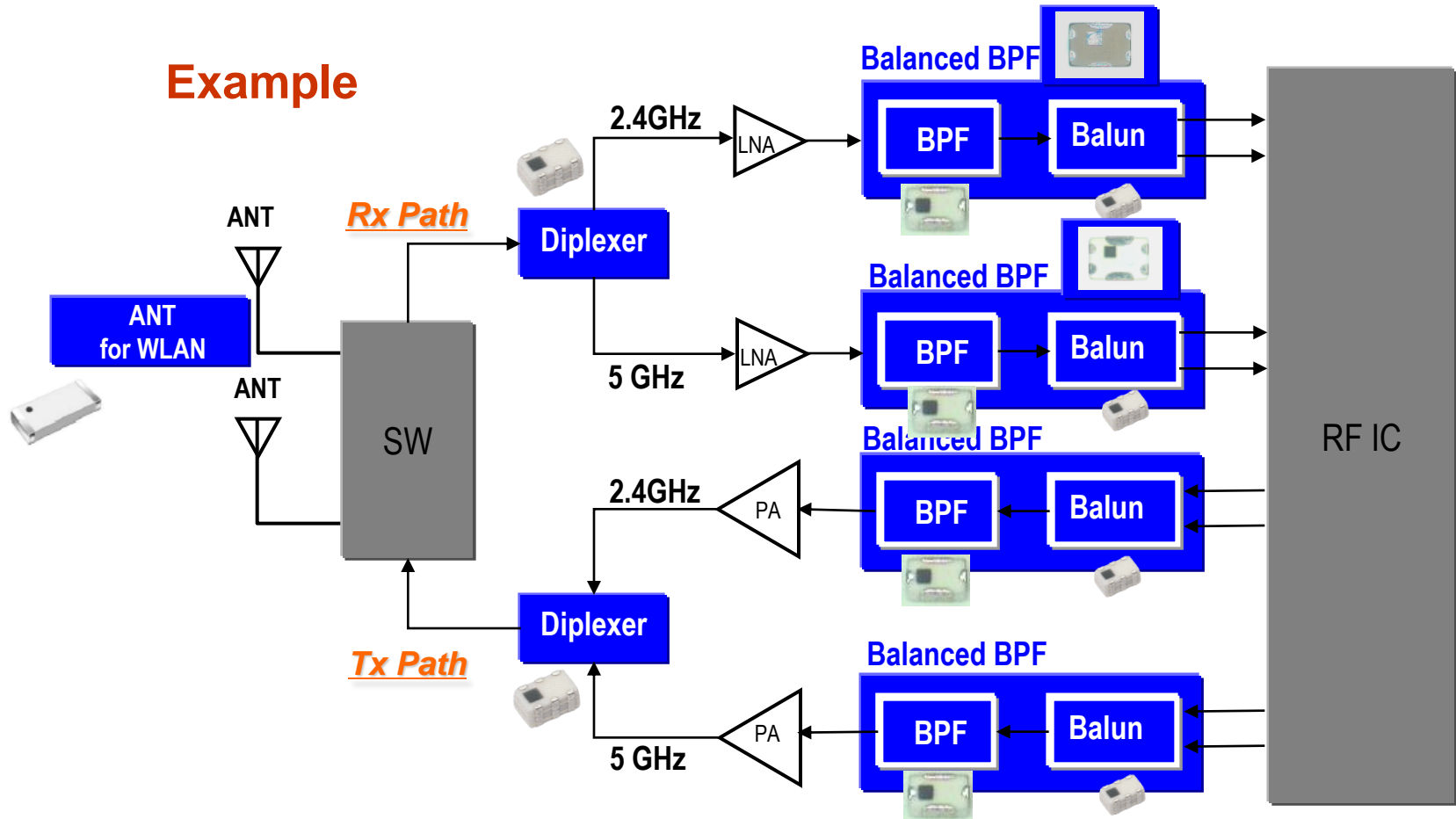

TDK RF Components for Bluetooth

- Bluetooth Block diagram

Example 1

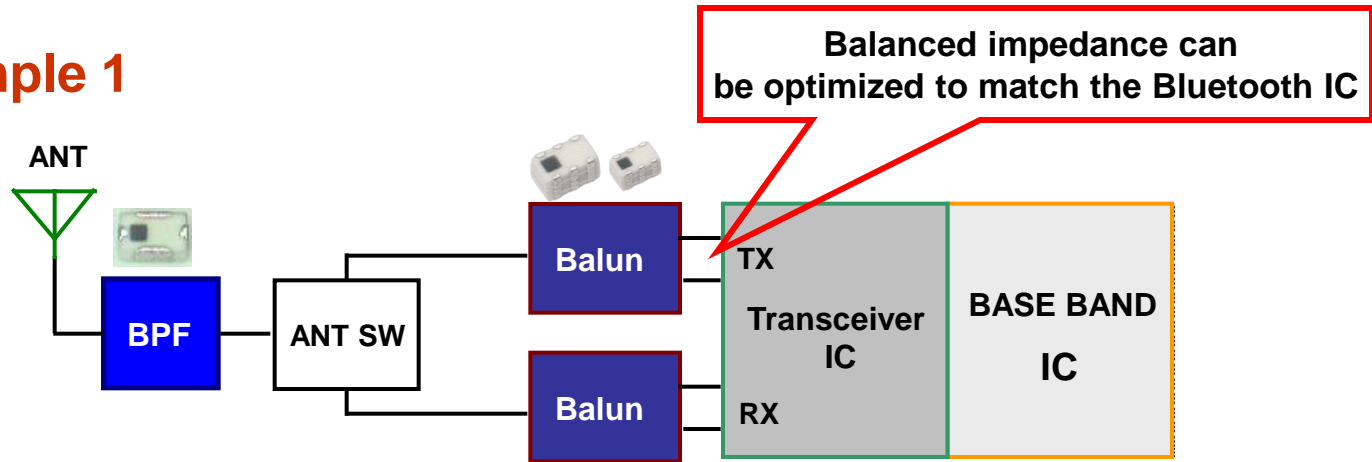

Example 2

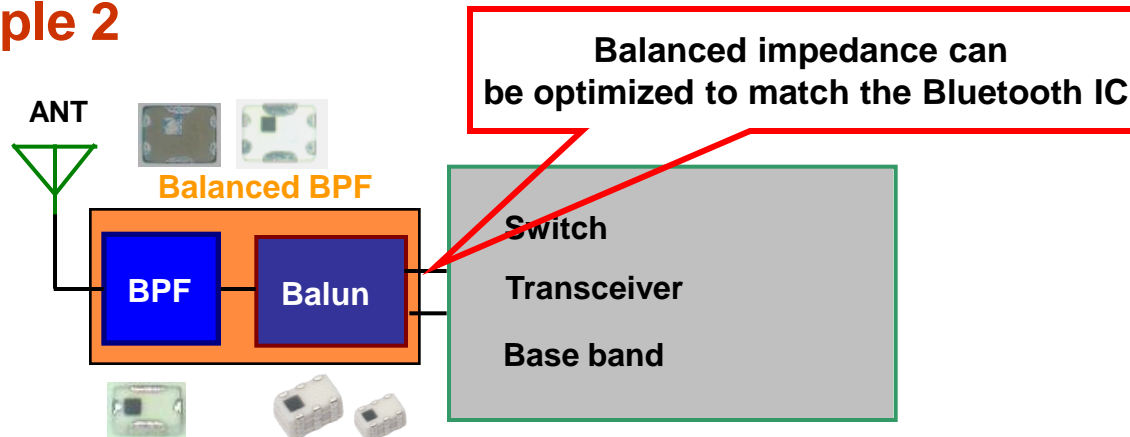

TDK RF Components for WiMAX

- WiMAX Block diagram (*Dualband*)

Example

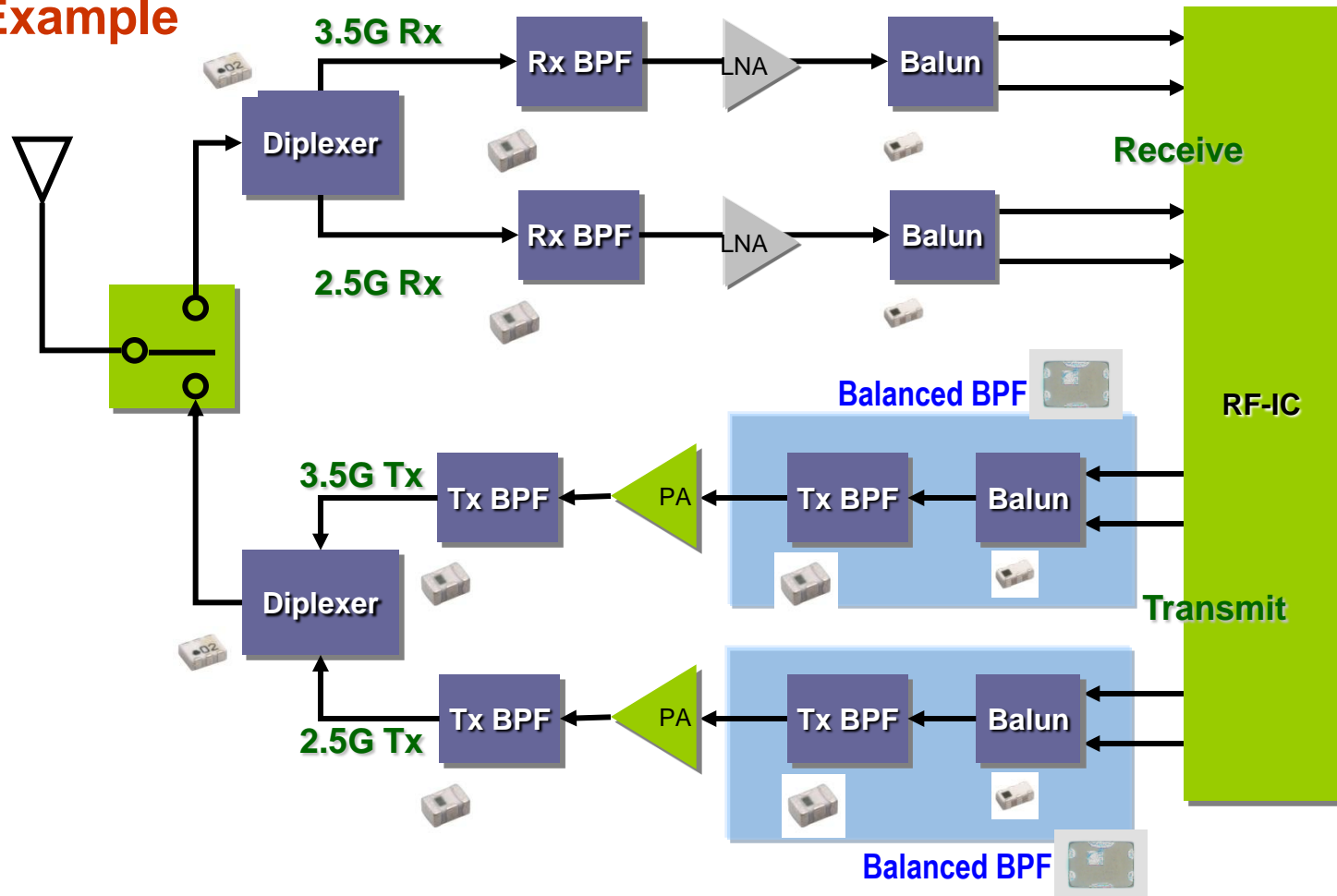

TDK RF Components for UWB

- UWB Block diagram

Example 1

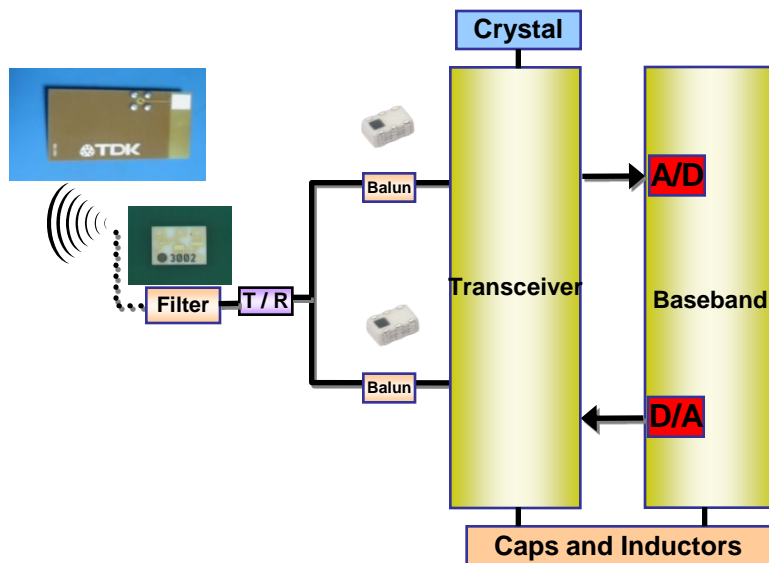

Example 2

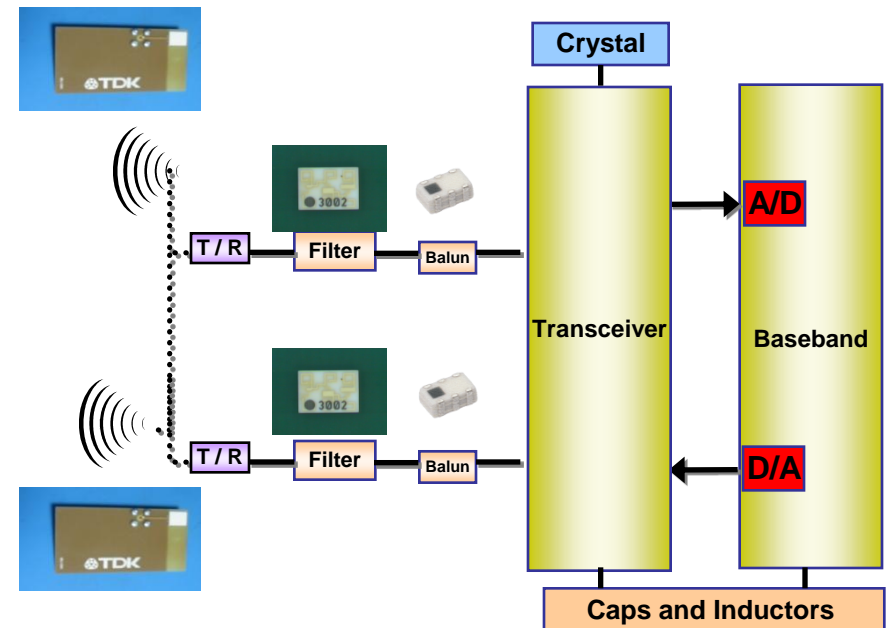

TDK RF Components



TDK RF Overview

- Why is TDK manufacturing RF components?
 - TDK has been instrumental in the development of RF technologies for over 15 years. TDK RF components use the same Low Temperature Co-fired Ceramic (LTCC) technology used in our ceramic capacitors and inductors. TDK RF components are designed to meet critical real-world applications from leading RF IC manufacturers.

Why Use TDK Components ?

- Miniature Size
 - As Wireless systems continue to be used in more and more applications, the need for smaller RF components increases. TDK's continuous materials development allows us to design smaller RF components without sacrificing performance and quality.
- TDK RF components are developed for specific IC's & applications
 - TDK works with Industry leading RF IC manufacturers to create RF components for use in WLAN, WiMAX, Bluetooth and UWB systems.

Global Presence : World-Wide Technical Support



**TDK R&D Corporation
Phoenix, USA**



**TDK Corporation
Tokyo, Japan**

TDK Maintains RF Design centers in Japan, Ireland and the US. These design centers are located close to our customers and partners to provide direct and close communications.



**TDK Electronics Ireland
Dublin, Ireland**



**TDK RF Solutions
Austin, USA**

Summary

- TDK RF Components are designed for use in various wireless technologies. TDK products provide the performance, size and cost targets to meet your RF product requirements. For more information please contact:
- Contacts
- TDK Website Links
 - http://www.tdk.co.jp/tefe02/rf_network.htm
- Links to Mouser's TDK Parts List