

**WHITE PAPER**

# Ultra Low Noise Amplifiers

By Stephen Moreschi and Jody Skeen

This white paper describes the performance and characteristics of two new ultra low noise LNAs from Skyworks. Topics include techniques used in biasing and matching these devices. A circuit description, including information on thermal considerations, is also addressed.

The SKY67150-396LF and SKY67153-396LF were designed to cover a wide bandwidth with the use of two separate devices with their design and performance analyzed from 30 MHz – 4.0 GHz. Package pin-outs for each device are identical, with the only differences in the applications schematic and frequency band of interest for each device. The remainder of the paper will primarily focus on the SKY67150-396LF but will also be applicable, unless otherwise noted, for the SKY67153-396LF.

The primary function of the LNA is to minimize the cascaded noise figure (NF) of the receiver. As described by the Friis equation, the LNA gain minimizes the cascaded NF impact of subsequent stages and its low NF minimizes its own NF contribution. This resulting low cascaded NF results in optimal receiver sensitivity in low signal level conditions and thus the LNA is a common receiver element in the vast majority of receiver architectures. In addition to its gain and NF characteristics, the LNA linearity should also be high enough so that this stage does not limit the cascaded input third order intercept point (IIP3) and input 1 dB compression point (IP<sub>1 dB</sub>) of the receiver.

The family of products presented here are ultra-high performance, low noise single stage amplifiers designed for wireless applications in the 30 MHz to 4.0 GHz band of interest. Targeted applications are any systems requiring ultra low noise figures, very good linearity and extended temperature performance to +105 °C ambient.

These single stage high linearity, high gain low noise GaAs pHEMT amplifiers are housed in a low thermal resistance 8-pin 2 x 2 mm<sup>2</sup> package. Thermal performance is also improved by the use of a low resistance high conductivity thermal epoxy which is used to attach the GaAs amplifier die to the package lead frame. This attachment method as well as rugged on-die structures gives the devices the ability to operate safely up to the +105 °C maximum ambient temperature. The LNAs active bias circuitry internally provides stable performance over temperature and process variations. Supply current is also controlled by adjusting one external resistor and can be varied over a very wide range independently from the device V<sub>DD</sub>. This feature allows the device efficiency to be optimized according to the linearity requirements of a particular application.

Any additional technical information required can be made available by Skyworks. If a new application from a customer requires a specialized tuning, requests may be forwarded as well.

### Design and Configuration

Figure 1 shows the active biasing and matching circuits required for the device to operate properly. The operating current will be set through the external resistor component, M6.

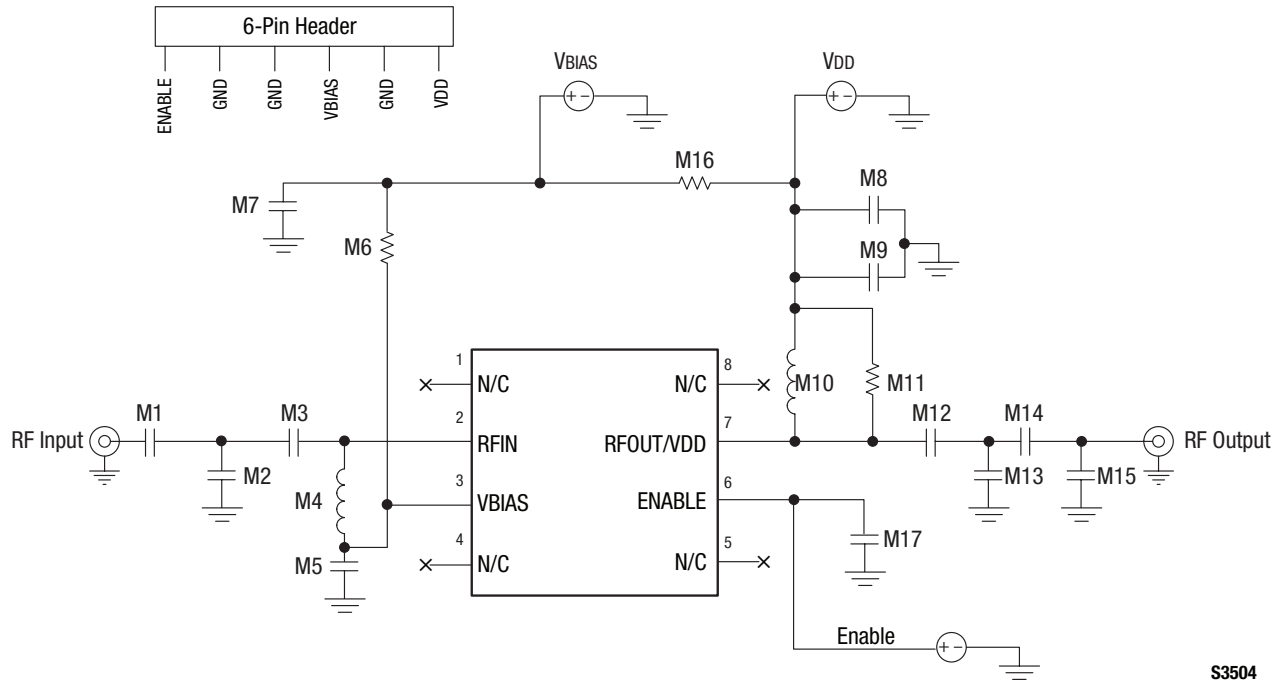

S3504

Figure 1. LNA Functional Schematic

A typical set of bias current vs. resistor values is shown in Figure 2. The recommended range of bias current for operating the modules is from 25 mA – 110 mA, with operating voltages that can range from 3.0 V – 5.0 V. Operating the devices anywhere within these ranges of bias conditions will result in excellent performance. Generally speaking, higher device quiescent current will result in higher IIP3 while higher V<sub>DD</sub> will result in higher IP<sub>1 dB</sub>. Gain (S(2,1)) and NF are relatively insensitive to device I<sub>ddq</sub> and measured results indicate little performance advantage from device currents higher than 100 mA.

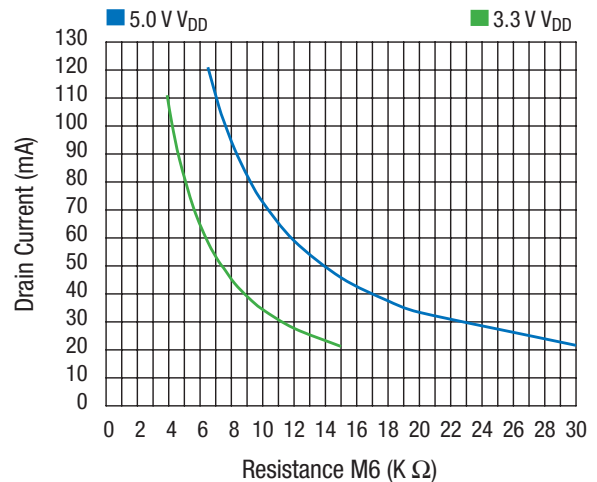

Figure 2. Bias Currents vs. External Resistance

Referring to Figure 1, components M1, M2, M3, M4 are used for matching Input Return Loss (S(1,1)) as well as NF. M4 also acts as a high impedance bias supply for the gate of the input FET, with M5 acting as an RF Short circuit at the frequency of operation. For optimal NF, all the input matching components should have high Q with wire-wound inductors offering an excellent combination of price and performance.

Component M10 acts as a high impedance bias feed for the drain of the output FET as well as part of the matching for output return loss (S(2,2)). Capacitor M9 is also part of the bias structure and acts as a short circuit to ground at the RF frequency of interest. It can also be used to match S(2,2) as well, but to a lesser degree than Inductor M10. Resistor M11, which is in parallel with M10, tends to de-Q the output match and this small resistive loading tends to provide extra stability margin especially at high frequency. A very minor degradation in gain, IP3 and P<sub>1 dB</sub> is incurred, but the effect is quite minimal at less than 0.5 dB.

Components M12, M13, M14 and M15 are all for output matching and are used mostly for the tuning of S(2,2), IP3 and P<sub>1 dB</sub>. High frequency stability is again also improved with the addition of resistor M15 with very minor degradations in performance as noted above. All devices on the output side of the amplifier can be standard Q components with no significant performance impact.

Both the SKY67150-396LF and the SKY67153-396LF have an enable or power down feature which is present on pin 7. The enable feature is active on a low signal input, <0.20 V and in this condition the amplifier is in the “ON” state. Levels above 1.50 V up to a maximum of 5.5 V will turn the amplifier to the “OFF” state and current consumption will be approximately 1.5 mA. Note that when in the “OFF” conditions RF signal levels of 0 dBm or more will begin to re-bias the gate of the input transistor and the device will begin to turn back on to some degree. For applications in which the device must remain off under high input power levels, it is recommended that the V<sub>DD</sub> be switched low to prevent this self-biasing from occurring.

Figure 3 shows the evaluation board (EVB) used to test and tune the LNA in its different tuning states. The board is comprised of a four-layer stack with the top layer being Rogers 4350B, 0.254 mm or 10 mils thick. Transmission Line Construction is coplanar with a ground plane spacing of 0.394 mm and via diameters are all 0.254 mm. Careful attention to the layout must be employed as to reduce the risk of stray capacitance or inductance which may result in decreased performance or instabilities in the device at especially high frequencies. Ground vias under the device must also be as detailed in Figure 4. An insufficient amount of ground via or those with increased inductance will increase the thermal resistance of the device, lowering its maximum operating temperature, as well as potentially induce high frequency instabilities in the amplifier from increased source inductance.

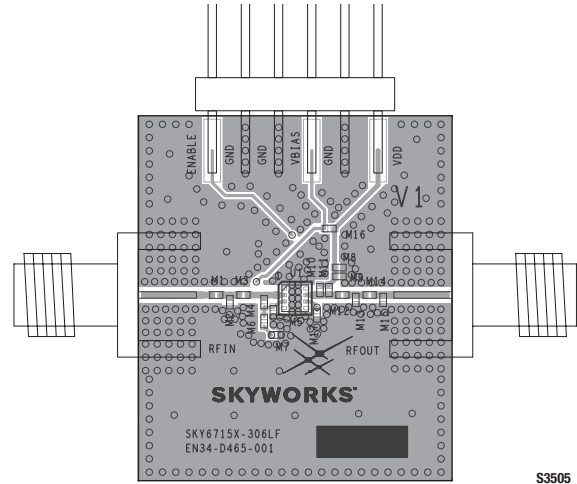

Figure 3. Applications Circuit

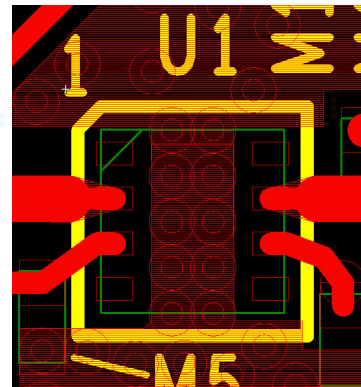

Figure 4. Ground Via Land Pattern

### Typical Performance Data

There are a variety of matching structures which can be employed to cover as an example the performance of the SKY67150-396LF from 30 MHz to 2200 MHz. For this example, consider the tuning from 650 MHz to 1100 MHz. Figures 5–9 highlight the typical small signal performance at 5 V and 82 mA. The device has been tuned for lowest NF in this example, while still maintaining a reasonable  $S(1,1)$  of -11.3 dB. The measured noise figure of the complete evaluation board with this particular set of matching components was found to be 0.25 dB at 849 MHz. This extremely low noise figure actually challenges the accuracy of the measurement equipment which has on its own uncertainty factor for the measurement. The device can also be tuned if required for best  $S(1,1)$  at the expense of slightly degraded noise figure. As an example with an  $S(1,1)$  of approx. -18 dB or less, the measured NF would degrade to 0.30 to 0.35 dB. Gain ( $S(2,1)$ ) for the device under these conditions was 20.5 dB and  $S(2,2)$  was measured to be -20 dB. Note also that the even with this excellent output match and high gain the output IP3 was +39 dBm or equivalently +18.5 dBm input IP3. Output compression point was also measured to be +21 dBm ( $OP_1$  dB), +15 dBm ( $IP_1$  dB). So not only is the SKY67150-396LF an ultra-low noise amplifier which was primarily designed as an input or stage-one amplifier, it also has the ability to be a stage-two device because of its excellent linearity characteristics. The device also yields very good reverse isolation ( $S12$ ), +28.0 dBm, making it very insensitive to load matching while trying to match the input for lowest noise or best  $S11$ .

Stability vs. frequency and temperature is shown in Figures 10 and 11. Stability factors vs. bias voltage and current stay quite uniform and controlled. It is important that the applications circuit grounding of the device paddle be adhered to (Figure 4). This will ensure a good thermal contact as well as provide a low inductance path to ground for terminating RF currents.

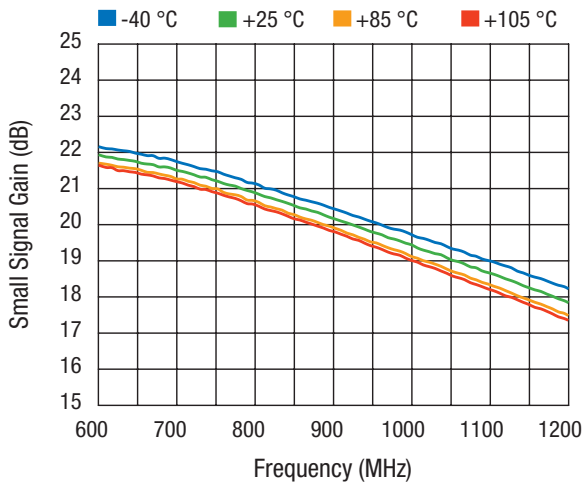

Figure 5. Small Signal Gain

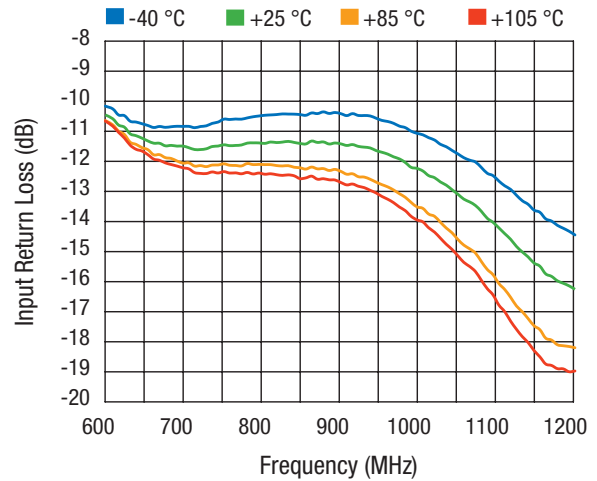

Figure 6. Input Return Loss

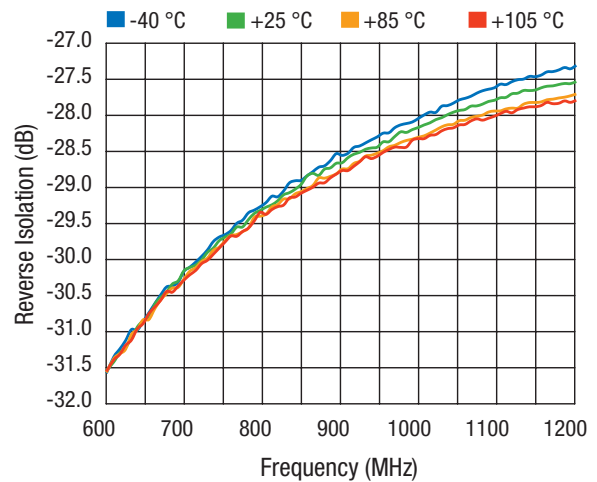

Figure 7. Reverse Isolation

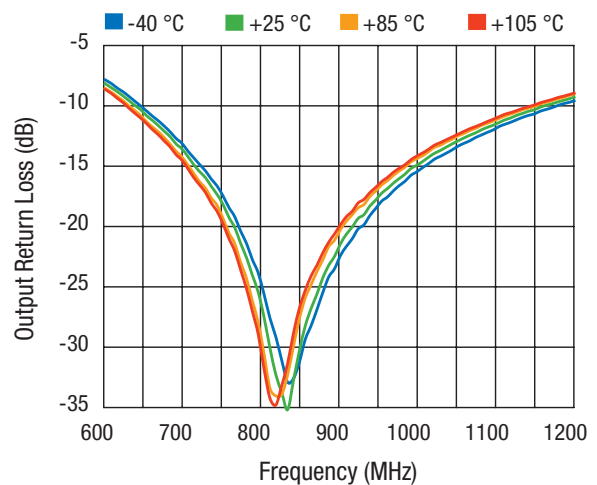

Figure 8: Output Return Loss

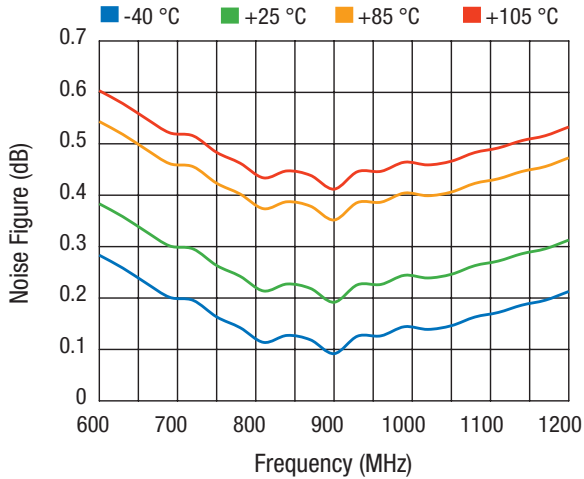

Figure 9. Noise Figure

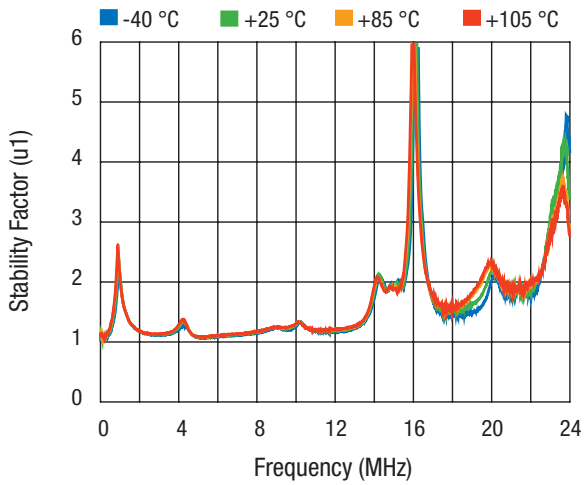

Figure 10. Stability Factor (u1)

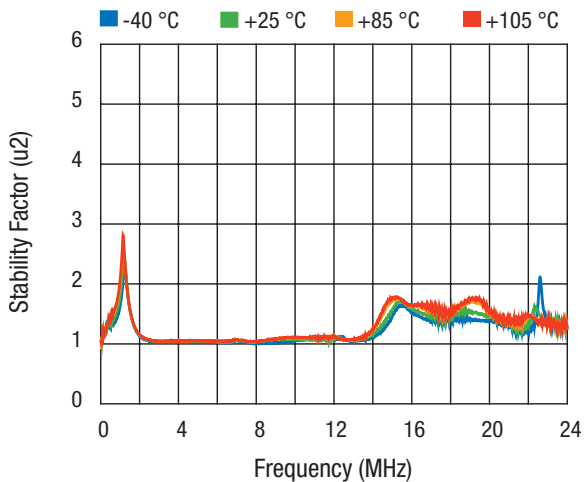

Figure 11. Stability Factor (u2)

### Low Frequency Performance Data

By revising the application circuit slightly, the SKY67150-396LF also has the ability to extend down to 30 MHz. Resistive feedback from output of the device directly back to the input of the device has been added as shown in Figure 12. This feedback results in a low NF solution with excellent linearity and stability, along with good input and output return losses. Typical low frequency performance at 100 MHz with this feedback present is shown in Table 1.

This is a clear example of the outstanding performance capability of this LNA over a wide range of application frequencies.

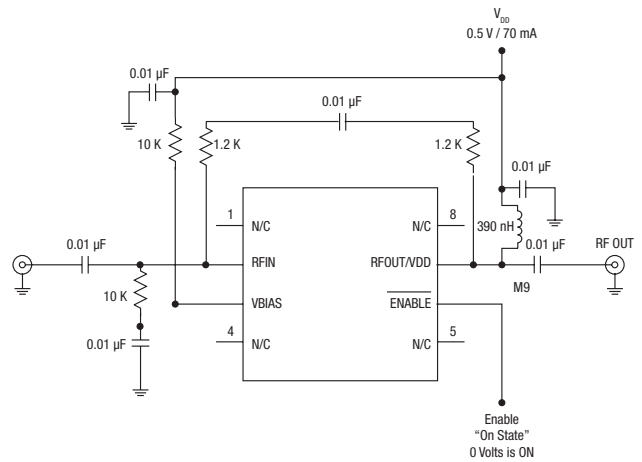

Figure 12. Low Frequency Schematic With Feedback

### SKY67150-396LF Frequency Response Data

Shown in Table 1 is the frequency banded performance of the SKY67150-396LF. Please note however that the lowest frequency tuning, 30 MHz – 400 MHz requires the addition of an extra feedback path which is shown in Figure 12.

Table 2 highlights the frequency banded performance of the SKY67153-396LF.

**Table 1. SKY67150-396LF LNA Typical RF Performance vs. Band**

2 x 2 Low Noise Amplifier Part Number		SKY67150	SKY67150	SKY67150	SKY67150		
Frequency Band		30–400 MHz	380–530 MHz	650–1100 MHz	1.4–2.2 MHz		
Test Frequency		100 MHz	450 MHz	849 MHz	1900 MHz		
Parameter	Denotation	Condition	Typical RF Performance				Unit
Noise Figure	NF		0.33	0.45	0.23	0.38	dB
Small Signal Gain	[S21]		28.5	23	20.5	14.5	dB
Input Return Loss	[S11]		9.7	12	11	17	dB
Output Return Loss	[S22]		12.7	20	20	20	dB
Reverse Isolation	[S12]		33.7	33	28	23	dB
Input Third Order Intercept Point	IIP3	$\Delta F = 2 \text{ MHz},$ $P_{IN} = -20 \text{ dBm/Tone}$	4.4	13	18.5	22	dBm
Output Third Order Intercept Point	OIP3	$\Delta F = 2 \text{ MHz},$ $P_{IN} = -20 \text{ dBm/Tone}$	32.7	36	39	36.5	dBm
Input 1 dB Compression Point	IP <sub>1</sub> dB		-5.9	-3	1.5	4.5	dBm
Output 1 dB Compression Point	OP <sub>1</sub> dB		19.9	19	21	18	dBm
Stability	$\mu_1, \mu_2, K, B$		>1	>1	>1	>1	–
<b>DC Specifications</b>							
Supply Voltage	V <sub>DD</sub>		5	5	5	5	V
Quiescent Supply Current	I <sub>DD</sub>		70	82	85	82	mA

**Table 2. SKY67153-396LF LNA Typical RF Performance vs. Band**

2 x 2 Low Noise Amplifier Part Number			SKY67153	SKY67153	SKY67153	SKY67153	
Frequency Band			70–1000 MHz	1600–2200 MHz	2300–2700 MHz	3400–3800 MHz	
Test Frequency			849 MHz	1850 MHz	2500 MHz	1900 MHz	
Parameter	Denotation	Condition	Typical RF Performance				Unit
Noise Figure	NF		0.25	0.35	0.5	0.7	dB
Small Signal Gain	[S21]		26	20.5	19	16.5	dB
Input Return Loss	[S11]		12	12	11	10	dB
Output Return Loss	[S22]		18	16	20	16	dB
Reverse Isolation	[S12]		33	29	28	28	dB
Input Third Order Intercept Point	IIP3	$\Delta F = 2 \text{ MHz}$ , $P_{IN} = -20 \text{ dBm/Tone}$	8.8	15.5	17	19.5	dBm
Output Third Order Intercept Point	OIP3	$\Delta F = 2 \text{ MHz}$ , $P_{IN} = -20 \text{ dBm/Tone}$	34.5	36	36	36	dBm
Input 1 dB Compression Point	IP <sub>1</sub> dB		-3.5	1	2	2.5	dBm
Output 1 dB Compression Point	OP <sub>1</sub> dB		21.5	20.5	20	18	dBm
Stability	$\mu 1, \mu 2, K, B$		>1	>1	>1	>1	–
DC Specifications							
Supply Voltage	V <sub>DD</sub>		5	5	5	5	V
Quiescent Supply Current	I <sub>DD</sub>		80	70	72	80	mA

Two new ultra low noise LNAs in 2 x 2 mm<sup>2</sup> 8-pin packages have been presented. Both devices achieve extremely low noise figure, excellent stability, high linearity and gain using simple external matching circuits which allow these devices to cover a frequency range of 30 MHz to 3.8 GHz and beyond. Their excellent linearity characteristics allow these devices to be used as both first and second stage LNAs and they can provide outstanding solutions for linear driver transmit applications as well. The various device application schematics offer solutions over the full application frequency range with unconditional stability over the full operating temperature range of -40 °C to +105 °C.

Further, we have shown that these devices can also be operated over a wide range of current and voltages thus allowing optimal efficiency given the linearity requirements of a particular application. Their outstanding performance at low voltages and currents makes these device ideal for high efficiency, high performance battery powered applications. Finally, the thermal characteristics of these parts allow them to achieve high long term reliability and excellent performance up to an ambient temperature of +105 °C making the devices ideal for applications having demanding environmental conditions such as military, automotive and cellular infrastructure.

For additional information on each of these devices please refer to the data sheets which are located at: [www.skyworksinc.com](http://www.skyworksinc.com).

Copyright © 2014, Skyworks Solutions, Inc. All Rights Reserved.

Information in this document is provided in connection with Skyworks Solutions, Inc. ("Skyworks") products or services. These materials, including the information contained herein, are provided by Skyworks as a service to its customers and may be used for informational purposes only by the customer. Skyworks assumes no responsibility for errors or omissions in these materials or the information contained herein. Skyworks may change its documentation, products, services, specifications or product descriptions at any time, without notice. Skyworks makes no commitment to update the materials or information and shall have no responsibility whatsoever for conflicts, incompatibilities, or other difficulties arising from any future changes.

No license, whether express, implied, by estoppel or otherwise, is granted to any intellectual property rights by this document. Skyworks assumes no liability for any materials, products or information provided hereunder, including the sale, distribution, reproduction or use of Skyworks products, information or materials, except as may be provided in Skyworks Terms and Conditions of Sale.

THE MATERIALS, PRODUCTS AND INFORMATION ARE PROVIDED "AS IS" WITHOUT WARRANTY OF ANY KIND, WHETHER EXPRESS, IMPLIED, STATUTORY, OR OTHERWISE, INCLUDING FITNESS FOR A PARTICULAR PURPOSE OR USE, MERCHANTABILITY, PERFORMANCE, QUALITY OR NON-INFRINGEMENT OF ANY INTELLECTUAL PROPERTY RIGHT; ALL SUCH WARRANTIES ARE HEREBY EXPRESSLY DISCLAIMED. SKYWORKS DOES NOT WARRANT THE ACCURACY OR COMPLETENESS OF THE INFORMATION, TEXT, GRAPHICS OR OTHER ITEMS CONTAINED WITHIN THESE MATERIALS. SKYWORKS SHALL NOT BE LIABLE FOR ANY DAMAGES, INCLUDING BUT NOT LIMITED TO ANY SPECIAL, INDIRECT, INCIDENTAL, STATUTORY, OR CONSEQUENTIAL DAMAGES, INCLUDING WITHOUT LIMITATION, LOST REVENUES OR LOST PROFITS THAT MAY RESULT FROM THE USE OF THE MATERIALS OR INFORMATION, WHETHER OR NOT THE RECIPIENT OF MATERIALS HAS BEEN ADVISED OF THE POSSIBILITY OF SUCH DAMAGE.

Skyworks products are not intended for use in medical, lifesaving or life-sustaining applications, or other equipment in which the failure of the Skyworks products could lead to personal injury, death, physical or environmental damage. Skyworks customers using or selling Skyworks products for use in such applications do so at their own risk and agree to fully indemnify Skyworks for any damages resulting from such improper use or sale.

Customers are responsible for their products and applications using Skyworks products, which may deviate from published specifications as a result of design defects, errors, or operation of products outside of published parameters or design specifications. Customers should include design and operating safeguards to minimize these and other risks. Skyworks assumes no liability for applications assistance, customer product design, or damage to any equipment resulting from the use of Skyworks products outside of stated published specifications or parameters.

Skyworks, the Skyworks symbol, and "Breakthrough Simplicity" are trademarks or registered trademarks of Skyworks Solutions, Inc., in the United States and other countries. Third-party brands and names are for identification purposes only, and are the property of their respective owners. Additional information, including relevant terms and conditions, posted at [www.skyworksinc.com](http://www.skyworksinc.com), are incorporated by reference.