



# LUXEON Mid-Power 5630 Emitters

## Assembly and Handling Information

### Introduction

This application brief addresses the recommended assembly and handling procedures for the LUXEON® Mid-Power 5630 emitters. These emitters deliver high efficacy and quality of light for distributed light source applications in a compact 5630 package. Proper assembly, handling, and thermal management, as outlined in this application brief, ensure high optical output and reliability of these mid-power emitters.

### Scope

The assembly and handling guidelines in this application brief apply to the following LUXEON Mid-Power 5630 products:

- MXL8-PW30
- MXL8-PW35
- MXL8-PW40
- MXL8-PW50
- MXL8-PW65

In the remainder of this document the term mid-power emitter refers to any product in the LUXEON Mid-Power 5630 product family.

# Table of Contents

|                                                                 |   |
|-----------------------------------------------------------------|---|
| I. Component .....                                              | 3 |
| 1.1 Description .....                                           | 3 |
| 1.2 Optical Center .....                                        | 3 |
| 1.3 Handling Precautions .....                                  | 3 |
| 1.4 Cleaning .....                                              | 3 |
| 1.5 Electrical Isolation .....                                  | 3 |
| 1.6 Mechanical Files .....                                      | 3 |
| 2. PCB Design Guidelines for the LUXEON Mid-Power Emitter ..... | 4 |
| 2.1 Mid-power Footprint and Land Pattern .....                  | 4 |
| 2.2 Surface Finishing.....                                      | 4 |
| 2.3 Minimum Spacing .....                                       | 4 |
| 3. Thermal Measurement Guidelines .....                         | 4 |
| 4. Assembly Process Guidelines .....                            | 5 |
| 4.1 Solder Paste .....                                          | 5 |
| 4.2 Solder Reflow Profile.....                                  | 5 |
| 4.3 Pick and Place .....                                        | 5 |
| 4.4 Placement Accuracy .....                                    | 6 |
| 4.5 Electrostatic Discharge Protection.....                     | 6 |
| 5. JEDEC Moisture Sensitivity Levels.....                       | 7 |
| 6. Packaging Considerations—Chemical Compatibility .....        | 7 |

# I. Component

## I.1 Description

The LUXEON Mid-Power 5630 emitter (Figure 1) consists of a 5630 lead-frame package with 5 pads: a thermal pad in the center, two cathodes, an anode, and an open. A small notch on the corner of the LED package marks the cathode side of the LED package. The “open” pad is electrically and thermally connected to the thermal pad. The LUXEON Mid-Power 5630 emitter does not include any transient voltage suppressor (TVS) chip to protect the emitter against electrostatic discharges (ESD), but it is capable of withstanding up to 2000V for HBM and 400V for MM ESD discharge conditions. Appropriate precautions should therefore be taken when handling this device (see Section 4.6).

## I.2 Optical Center

The optical center coincides with the mechanical center of the mid-power 5630 LED package. Optical rayset data for the mid-power emitter will be made available upon request.

## I.3 Handling Precautions

The LUXEON Mid-Power 5630 emitter is designed to maximize light output and reliability. However, improper handling of the device may damage the silicone coating and affect the overall performance and reliability. In order to minimize the risk of damage to the silicone coating during handling, the LUXEON Mid-Power 5630 emitter should only be picked up from the side of the package.

## I.4 Cleaning

The LUXEON Mid-Power 5630 emitter should not be exposed to dust and debris. Excessive dust and debris may cause a drastic decrease in optical output. In the event that a mid-power emitter requires cleaning, first try a gentle swabbing using a lint-free swab. If needed, a lint-free swab and isopropyl alcohol (IPA) can be used to gently remove dirt from the silicone coating. Do not use other solvents as they may adversely react with the mid-power package. For more information regarding chemical compatibility, see Section 6.

## I.5 Electrical Isolation

The thermal pad of the LUXEON Mid-Power 5630 emitter is electrically isolated from the cathodes and anode. Consequently, a high voltage difference between electrical and thermal metallization may occur in applications where multiple mid-power emitters are connected in series. As a reference, the shortest nominal distance between the electrical metallization and the thermal metallization of the mid-power emitter is 0.5mm.

## I.6 Mechanical Files

Mechanical drawings for the LUXEON Mid-Power 5630 emitter (2D and 3D) are available upon request.

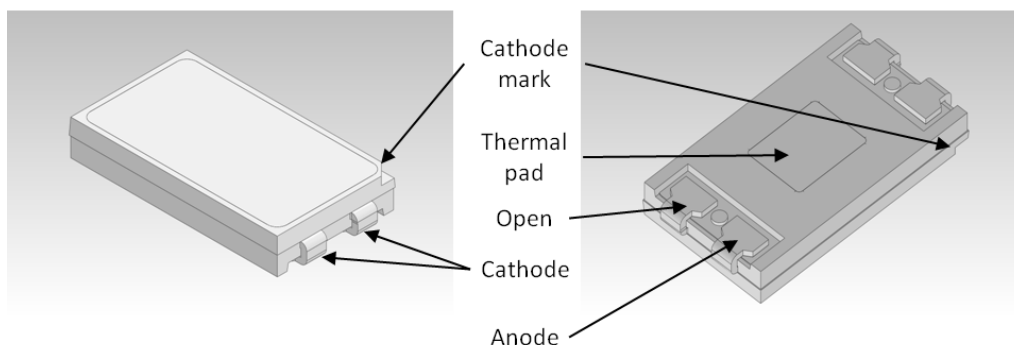

Figure 1. Package rendering of the LUXEON Mid-Power 5630 emitter.

## 2. PCB Design Guidelines for the LUXEON Mid-Power 5630 Emitter

The LUXEON Mid-Power 5630 emitter is designed to be soldered onto a Printed Circuit Board (PCB). To ensure optimal operation, the PCB should be designed to minimize the overall thermal resistance between the LED package and the heat sink.

### 2.1 Mid-power Footprint and Land Pattern

The recommended footprint design for the LUXEON Mid-Power 5630 emitter is shown in Figure 2.

### 2.2 Surface Finishing

Philips Lumileds recommends using a high temperature organic solderability preservative (OSP) on the copper layer.

### 2.3 Minimum Spacing

Philips Lumileds recommends a minimum edge to edge spacing between mid-power emitters of 1mm. Placing multiple mid-power emitters too close to each other may adversely impact the ability of the PCB to dissipate the heat from the emitters.

## 3. Thermal Measurement Guidelines

The typical thermal resistance  $R\theta_{j\text{-thermal pad}}$  between the junction and thermal pad for the LUXEON Mid-Power 5630 emitter is provided in the datasheet. With this information, the junction temperature  $T_j$  can be easily determined according to the following equation:

$$T_j = T_{\text{thermal pad}} + R\theta_{j\text{-thermal pad}} \cdot P_{\text{electrical}}$$

In this equation  $T_{\text{thermal pad}}$  is the temperature of the thermal pad (see Figure 1) and  $P_{\text{electrical}}$  is the electrical power going into the emitter.

In typical applications it may be difficult, though, to measure the thermal pad temperature  $T_{\text{thermal pad}}$  directly. Therefore, a practical way to determine the junction temperature of the LUXEON Mid-Power 5630 emitter is by measuring the temperature  $T_s$  of a predetermined sensor pad on the PCB right next to the emitter with a thermocouple. The recommended location of the sensor pad is near the open pad or near the thermal pad.

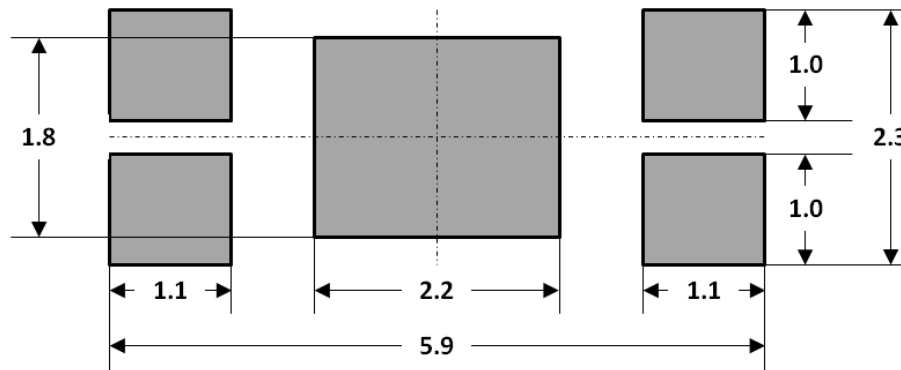

Figure 2. Recommended footprint design for the LUXEON Mid-Power 5630 emitter. All dimensions are in mm.

The thermal resistance  $R\theta_{j-s}$  between the sensor pad and the junction of the LUXEON Mid-Power 5630 emitter can be experimentally determined. The junction temperature can then be calculated as follows:

$$T_j = T_s + R\theta_{j-s} \cdot P_{\text{electrical}}$$

If needed, Philips Lumileds can provide guidance in conducting such an experiment.

## 4. Assembly Process Guidelines

### 4.1 Solder Paste

Philips Lumileds recommends lead-free solder with a typical thickness of 80µm after reflow for the LUXEON Mid-Power 5630 emitter. Philips Lumileds successfully tested SAC 305 solder paste from Alpha Metals (OM338 grade 3 and OM 325 grade 4) with satisfactory results. However, since application environments vary widely, Philips Lumileds recommends that customers perform their own solder paste evaluation in order to ensure it is suitable for the targeted application.

### 4.2 Solder Reflow Profile

The LUXEON Mid-Power 5630 emitter is compatible with standard surface-mount and lead-free reflow technologies. This greatly simplifies the manufacturing process by eliminating the need for adhesives and epoxies. The reflow step itself is the most critical step in the reflow soldering process and occurs when the boards move through the oven and the solder paste melts, forming the solder joints. To form good solder joints, the time and temperature profile throughout the reflow process must be well maintained.

A temperature profile consists of three primary phases:

1. Preheat: the board enters the reflow oven and is warmed up to a temperature lower than the melting point of the solder alloy.
2. Reflow: the board is heated to a peak temperature above the melting point of the solder, but below the temperature that would damage the components or the board.
3. Cool down: the board is cooled down rapidly, allowing the solder to freeze, before the board exits the oven.

As a point of reference, the melting temperature for SAC 305 is 217°C, and the minimum peak reflow temperature is 235°C.

### 4.3 Pick and Place

The LUXEON Mid-Power 5630 emitter is packaged and shipped in tape-and-reel which is compatible with standard automated pick-and-place equipment to ensure the best placement accuracy. Figure 3 shows the recommended pick-and-place nozzle design for the LUXEON Mid-Power 5630 emitter.

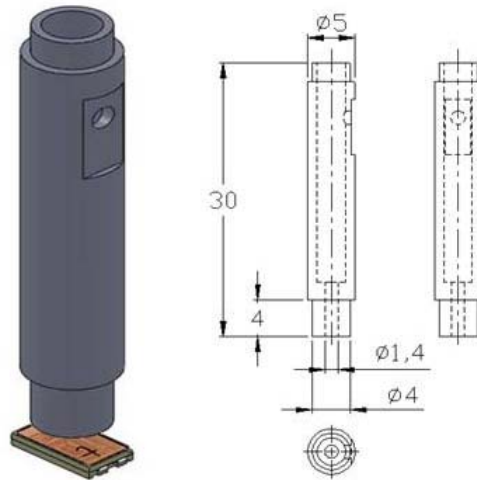

Figure 3. Recommended pick and place nozzle design for the LUXEON Mid-Power 5630 emitter.

#### 4.4 Placement Accuracy

Philips Lumileds has determined the placement accuracy after reflow to be well within 0.15mm in the x and y directions and 3 degrees in rotation, shown in Figure 4.

#### 4.5 Electrostatic Discharge Protection

The LUXEON Mid-Power 5630 emitter does not include any transient voltage suppressor (TVS) chip to protect against electrostatic discharges (ESD). Therefore, Philips Lumileds recommends observing the following precautions when handling the LUXEON Mid-Power 5630 emitter:

- During manual handling always use a conductive wrist band or anti-electrostatic glove.
- All equipment, machinery, work tables, and storage racks that may get in contact with the LUXEON Mid-Power 5630 emitter should be properly grounded.
- Use an ion blower to neutralize the static discharge that may build up on the surface and lens of the mid-power's plastic housing during storage and handling.

LUXEON Mid-Power 5630 emitters which are damaged by ESD may not light up at low currents and/or may exhibit abnormal performance characteristics such as a high reverse leakage current, and a low forward voltage. To determine whether any device is damage by ESD, measure the light output and forward voltage of the emitter which is suspect. A forward voltage above 2.0V for a drive current of 0.1mA typically indicates that the LED is not damaged.

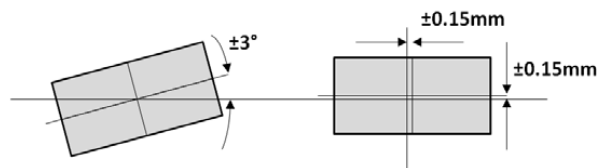

Figure 4. Typical placement accuracy after reflow.

## 5. JEDEC Moisture Sensitivity Levels

The LUXEON Mid-Power 5630 emitter has a JEDEC moisture sensitivity level of 3. This means that the LUXEON Mid-Power 5630 emitter has a floor life of up to one year if the original moisture proof packaging is intact, with the desiccants inside, and if the emitter is stored below 30°C with a relative humidity of 90% or less. Once the original moisture proof packaging is opened, the emitter should be stored below 30°C with a relative humidity of 60%. Reflow of the emitter is recommended within 72 hours after opening of the packaging. The moisture proof packaging contains a humidity card which indicates the maximum relative humidity the card has been exposed to (see Figure 5). If the humidity indicator in the package has turned pink (for more details, see the instructions on the humidity indicator in the package) or if the emitter has been outside the packaging for more than 168 hours, the LUXEON Mid-Power 5630 emitter should be baked for at least 33 hours at 90°C before reflow. Unused emitters should be sealed in the original moisture proof packaging with the original desiccant.

## 6. Packaging Considerations—Chemical Compatibility

The LUXEON Mid-Power 5630 emitter package contains a silicone overcoat to protect the LED chips and extract the maximum amount of light. As with most silicones used in LED optics, care must be taken to prevent any incompatible chemicals from directly or indirectly reacting with the silicone.

The silicone overcoat used in the LUXEON Mid-Power 5630 emitter is gas permeable. Consequently, oxygen and volatile organic compound (VOC) gas molecules can diffuse into the silicone overcoat. VOCs may originate from adhesives, solder fluxes, conformal coating materials, potting materials and even some of the inks that are used to print the PCBs.

Some VOCs and chemicals react with silicone and produce discoloration and surface damage. Other VOCs do not chemically react with the silicone material directly but diffuse into the silicone and oxidize during the presence of heat or light. Regardless of the physical mechanism, both cases may affect the total LED light output. Since silicone permeability increases with temperature, more VOCs may diffuse into and/or evaporate out from the silicone.

Careful consideration must be given to whether mid-power emitters are enclosed in an “air tight” environment or not. In an “air tight” environment, some VOCs that were introduced during assembly may permeate and remain in the silicone dome. Under heat and “blue” light, the VOCs inside the dome may partially oxidize and create a silicone discoloration, particularly on the surface of the LED where the flux energy is the highest. In an air rich or “open” air environment, VOCs have a chance to leave the area (driven by the normal air flow). Transferring the devices which were discolored in the enclosed environment back to “open” air may allow the oxidized VOCs to diffuse out of the silicone dome and may restore the original optical properties of the LED.

Determining suitable threshold limits for the presence of VOCs is very difficult since these limits depend on the type of enclosure used to house the LEDs and the operating temperatures. Also, some VOCs can photo-degrade over time.

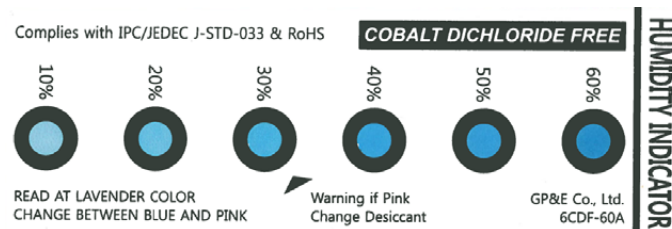

Figure 5. The LUXEON Mid-Power 5630 emitters are shipped in a moisture proof package with desiccant and a humidity card.

**Table 1. List of commonly used chemicals that will damage the silicone dome of the LUXEON Mid-Power 5630 emitter. Avoid using any of these chemicals in the housing that contains the LED package.**

| Chemical Name                                            | Normally Used as |
|----------------------------------------------------------|------------------|
| hydrochloric acid                                        | acid             |
| sulfuric acid                                            | acid             |
| nitric acid                                              | acid             |
| acetic acid                                              | acid             |
| sodium hydroxide                                         | alkali           |
| potassium hydroxide                                      | alkali           |
| ammonia                                                  | alkali           |
| MEK (Methyl Ethyl Ketone)                                | solvent          |
| MIBK (Methyl Isobutyl Ketone)                            | solvent          |
| Toluene                                                  | solvent          |
| Xylene                                                   | solvent          |
| Benzene                                                  | solvent          |
| Gasoline                                                 | solvent          |
| Mineral spirits                                          | solvent          |
| dichloromethane                                          | solvent          |
| tetrachlorometane                                        | solvent          |
| Castor oil                                               | oil              |
| lard                                                     | oil              |
| linseed oil                                              | oil              |
| petroleum                                                | oil              |
| silicone oil                                             | oil              |
| halogenated hydrocarbons (containing F, Cl, Br elements) | misc             |
| rosin flux                                               | solder flux      |
| acrylic tape                                             | adhesive         |

Table 1 provides a list of commonly used chemicals that should be avoided as they may react with the silicone material. Note that Philips Lumileds does not warrant that this list is exhaustive since it is impossible to determine all chemicals that may affect LED performance.

The chemicals in Table 1 are typically not directly used in the final products that are built around mid-power emitters. However, some of these chemicals may be used in intermediate manufacturing steps (e.g. cleaning agents). Consequently, trace amounts of these chemicals may remain on (sub)components, such as heat sinks. Philips Lumileds, therefore, recommends the following precautions when designing your application:

- When designing secondary lenses to be used over an LED, provide a sufficiently large air-pocket and allow for “ventilation” of this air away from the immediate vicinity of the LED.
- Use mechanical means of attaching lenses and circuit boards as much as possible. When using adhesives, potting compounds and coatings, carefully analyze its material composition and do thorough testing of the entire fixture under High Temperature over Life (HTOL) conditions.



# Company Information

Philips Lumileds is a leading provider of LEDs for everyday lighting applications. The company's records for light output, efficacy and thermal management are direct results of the ongoing commitment to advancing solid-state lighting technology and enabling lighting solutions that are more environmentally friendly, help reduce CO<sub>2</sub> emissions and reduce the need for power plant expansion. Philips Lumileds LUXEON® LEDs are enabling never before possible applications in outdoor lighting, shop lighting, home lighting, consumer electronics, and automotive lighting.

Philips Lumileds is a fully integrated supplier, producing core LED material in all three base colors, (Red, Green, Blue) and white. Philips Lumileds has R&D centers in San Jose, California and in the Netherlands, and production capabilities in San Jose, Singapore and Penang, Malaysia. Founded in 1999, Philips Lumileds is the high flux LED technology leader and is dedicated to bridging the gap between solid-state technology and the lighting world. More information about the company's LUXEON LED products and solid-state lighting technologies can be found at [www.philipslumileds.com](http://www.philipslumileds.com).

#### Disclaimer

PHILIPS LUMILEDS LIGHTING COMPANY shall not be liable for any kind of loss of data or any other damages, direct, indirect or consequential, resulting from the use of the provided information and data. Although PHILIPS LUMILEDS LIGHTING COMPANY has attempted to provide the most accurate information and data, the materials and services information and data are provided "as is" and PHILIPS LUMILEDS LIGHTING COMPANY neither warranties, nor guarantees the contents and correctness of the provided information and data. PHILIPS LUMILEDS LIGHTING COMPANY reserves the right to make changes without notice. You as user agree to this disclaimer and user agreement with the download or use of the provided materials, information and data.

©2012 Philips Lumileds Lighting Company. All rights reserved.  
Product specifications are subject to change without notice.

**PHILIPS**  
**LUMILEDS**

[www.philipslumileds.com](http://www.philipslumileds.com)  
[www.philipslumileds.cn.com](http://www.philipslumileds.cn.com)