

# INTEGRATED WIRELESS POWER SUPPLY RECEIVER, Qi (WIRELESS POWER CONSORTIUM) COMPLIANT — Evaluation Board User's Guide —

## FEATURES

- Integrated Wireless Power Receiver Solution
- WPC Ver. 1.1 Compliant
- Synchronous Full Bridge Rectifier Control
- Input Voltage Range : VRECT = 4.4 V to 19 V
- Selectable Output Voltage: 5 V
- Temperature Detecting Circuit
- Full Charge Detection with Adjustable Current Level
- Switching Control of External Power Supply
- Supports Under Voltage Lockout , Thermal Shutdown, Over Voltage Detection, and Over Current Detection.
- LED Indicator
- 3.16 mm X 3.16 mm WLCSP  
48 Pins with 0.4mm pitch

## DESCRIPTION

AN32258A is a wireless power system controller IC which is compliant with Qi version 1.1 of the System Description Wireless Power Transfer, Volume 1 for Low Power defined by Wireless Power Consortium. AN32258A is a controller IC of a power receiver (Rx) which can be used with any Qi-compliant wireless chargers.

## APPLICATIONS

- WPC Compliant Receivers
- Cell Phones, Smartphones
- Headsets
- Digital Cameras
- Tablet Devices
- Portable Media Players etc.

## IMPORTANT

AN32258A is designed to be used based on the circuits and external components described in this document and Application Note. Therefore, Panasonic cannot support any inquiries of modified solution.

## Wireless Power System

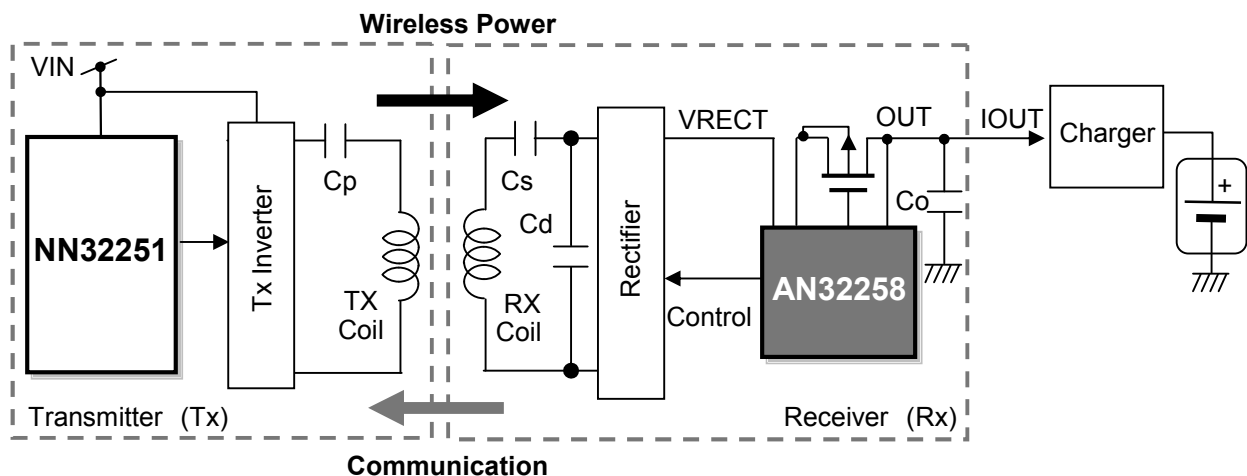

**EVB (for Qi 5W) Information**

1. EVB Circuit Diagram

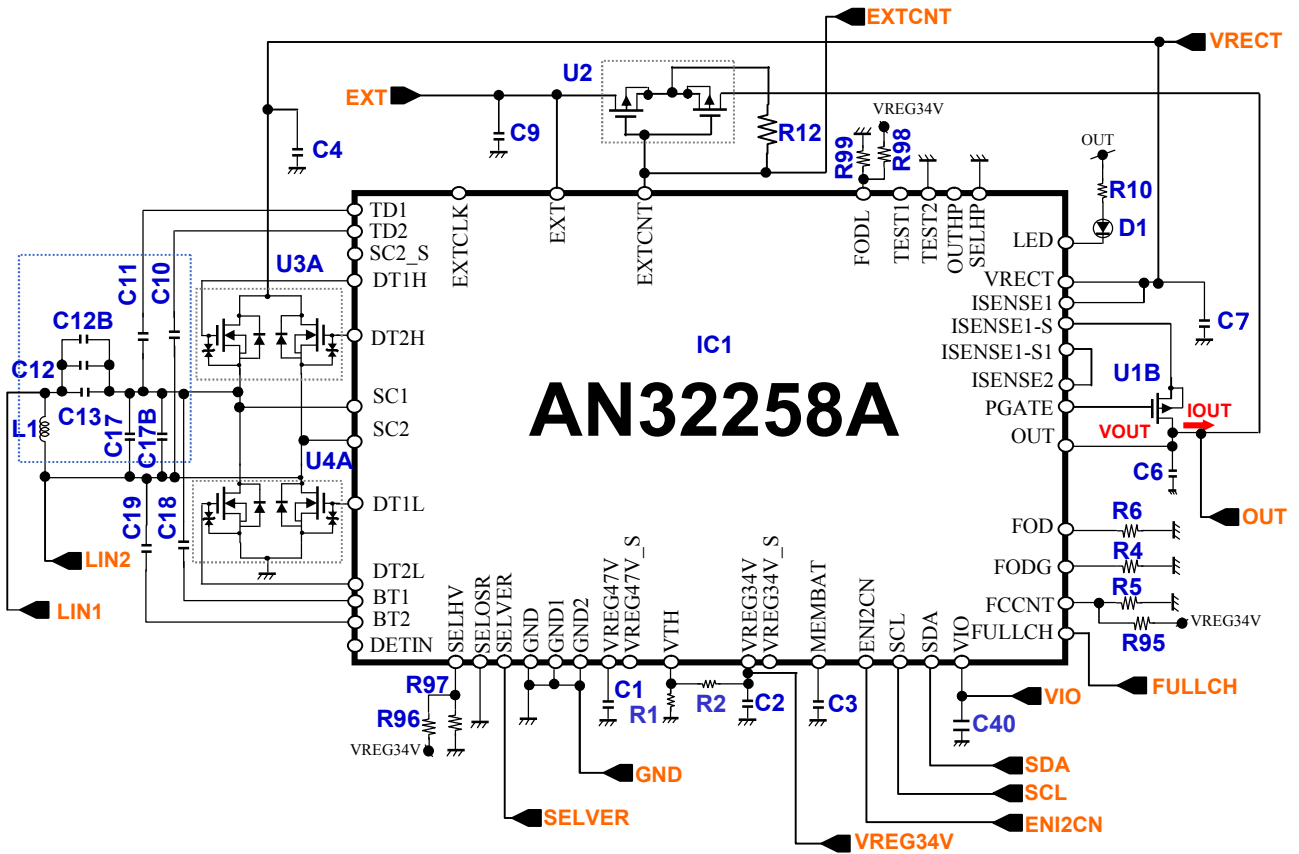

## EVB (for Qi 5W) Information (Continued)

### 2. Bill of Materials

#### 2-1. Mounting parts

Category	Parts No.	Name	Manufacture	Value	Rating	Size (JIS or PKG)	T(max) mm	Qty
IC	IC1	AN32258A	Panasonic	-	-	3.16*3.16	0.50	1
Coil	L1	KNCWA15C545Z	Panasonic	15 uH	-	54*40	0.53 (Typ)	1
Capacitor	C1-3	GRM155B31A105KE15	Murata	1.0uF	10V	1005	0.55	3
	C4	GRM219B31E106KA12	Murata	10uF	25V	2125	0.95	1
	C6	GRM188B31C475KAAJ	Murata	4.7uF	16V	1608	0.95	1
	C10,C11	GRM155R71H223KA12	Murata	22000pF	50V	1005	0.55	2
	C12,C12B	GRM188R71H683KA93#	Murata	68000pF	50V	1608	0.90	2
	C13	GRM188R71H473KA61#	Murata	47000pF	50V	1608	0.90	1
	C17	GRM155R11H102KA01#	Murata	1000pF	50V	1005	0.55	1
	C17B	GRM155R11H681KA01#	Murata	680pF	50V	1005	0.55	1
C18, C19	GRM155B31E104KA87	Murata	0.1uF	25V	1005	0.55	2	
Resistor	R2	ERJ2RKF4702X	Panasonic	47k ohm	1%	1005	0.4	1
	R4	ERJ2RKF3302X	Panasonic	33k ohm	1%	1005	0.4	1
	R6	ERJ2RKF1003X	Panasonic	100k ohm	1%	1005	0.4	1
	R10	ERJ2RKF5600X	Panasonic	560 ohm	1%	1005	0.4	1
	R95, R99	ERJ2GE0R00X	Panasonic	0 ohm	-	1005	0.4	2
P-MOS FET	U1B	MTM231232LBF	Panasonic	-	-	2.0*2.1	1.1	1
Dual N-MOS FET	U3A,U4A	FC8V33030L	Panasonic	-	-	WMini8-F1 (2.8*2.9)	0.85	2
LED	D1	LNJ237W82RA	Panasonic	-	-	1608	0.20	1

**EVB (for Qi 5W) Information (Continued)**

3. EVB Layout

3-1. Evaluation Board



EVB Photo (Top)



EVB Photo (Bottom)

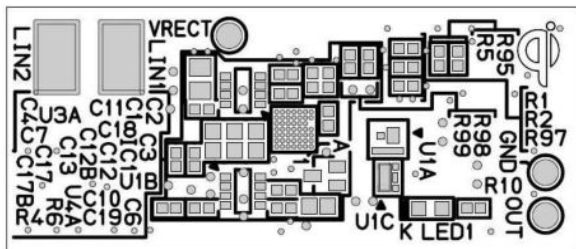

EVB Top Assembly

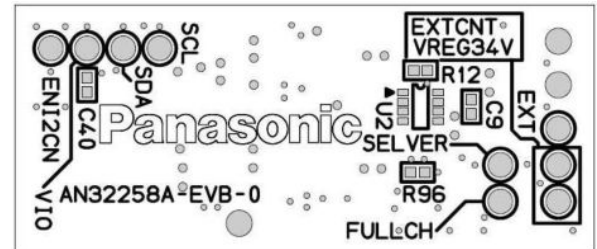

EVB Bottom Assembly

3-2. Specification of EVB

Category	Specification
EVB size	40.0 mm × 17.0 mm
Thickness	0.80 mm
Layer	4 layers

Note : The circuit and layout are designed for this evaluation board only. Thorough verification and evaluation must be done for the final product at your own risk.

## EVB (for Qi 5W) Information (Continued)

### 4. Monitor Pin Functions

Name	I/O	Function	Description
LIN1	I	Rx coil 1	Connect a receiver coil
LIN2	I	Rx coil 2	Connect a receiver coil
EXT	Power Supply	External power detection	Supplies power externally in direct. When EXT becomes larger than 4.2V, EXTCNT will become low and the wireless power transmission will stop. The external power supply will then directly output, and the Tx will be stopped.
EXCNT	O	External PMOS control	Controls the switch to an external power supply. When EXT is larger than 4.2V, EXTCNT will become low and the external MOSFET will turn on.
VRECT	Power Supply	Voltage of rectifier	Voltage of the rectifier output becomes the power supply of AN32258A.
OUT	I	LDO feedback	Connects to the PMOS drain of the LDO
GND	GND	Ground	
FULLCH	I	Full charge detection	This input controls the full charge detection externally such as from an MCU. When a high voltage level (over 1.6V) is inputted for over 50us, AN32258A will recognize it as full-charge and send packets to Tx to stop the power transmission. Right after the input becomes low, the power transmission can restart.
SELVER	I	Test pin	Leave this pin open. Panasonic uses this pin for test purposes only.
ENI2CN	O	Test pin	Leave this pin open. Panasonic uses this pin for test purposes only.
VIO	Power Supply	Test pin	Leave this pin open. Panasonic uses this pin for test purposes only.
SCL	I	Test pin	Leave this pin open. Panasonic uses this pin for test purposes only.
SDA	I/O	Test pin	Leave this pin open. Panasonic uses this pin for test purposes only.
VREG34V	O	Internal regulator output	Outputs a voltage level of 3.4V. This output cannot be used for external devices.

**EVB (for Qi 5W) Information (Continued)**5. Procedure

## 5-1. Preparation

- Charger pad of Qi compliant
- Voltage / Current meters
- Output load, such as resistors or a battery with charge control



EVB with a coil



An example of charge pads

## 5-2. Procedure

- (1) Connect wires to the pins named OUT and GND. Then, put the coil on the charge pad in such a way that the wire side of the coil faces to the pad.
- (2) After the authentication sequence, the pad starts to transmit power. The LED turns on when AN32258A receives power. An output of 5 volts can also be measured at the pin OUT. Either the red LED or the 5 volts output affirms that the board is properly operating.
- (3) Load current up to 1 A at the output is possible.

## 5-3. Notice

- When the Rx coil is replaced to another one, the resonance capacitors (C12-13, C17) may need to be changed. However, Panasonic cannot support any inquiries of modified solution.

# Mouser Electronics

Authorized Distributor

Click to View Pricing, Inventory, Delivery & Lifecycle Information:

Panasonic:

[AN32258A-EVB-0](#) [AN32258A-EVB-1](#)