











- Murata's new line of ESD devices are ideal for today's high speed data lines. The products are manufactured to function in compliance with IEC 61000-4-2 Level 4 (8kV Contact and 15kV Air Discharge).
- Ultra low capacitance (0.05pF typical) is achieved with our ceramic version. The ceramic product also provides Bi-directional operation and is RoHS compliant, Halogen free, and Lead free.
- A capacitance as low as 0.25pF can be provided with our silicon versions. These versions are available in single or multi-channel configurations and offer very low trigger and clamping voltages.
- Fast response time (<1ns)
- Application Examples:
 - HDMI 1.3, USB 2.0/3.0, IEEE 1394b
 - Cell Phones, Computers and peripherals
 - A/V Equipment, STB, DVD, HDTV, etc.
 - Antenna Ports



Product Line-Up

# of Channels	Part number	Capacitance (pF - typical)	Breakdown Voltage**		L x W (mm)	T (mm max)	Appearance (not to scale)
			Min.	Max.			
1	LXES15AAA1-100	0.05			1.0 x 0.5	0.33	
	LXES1UBBB1-008	0.50	7	10	1.0 x 0.6	0.6	
	LXES1UBAB1-007		18.7		1.0 x 0.6	0.6	
	LXES1UBAA1-096*	7.50	5.8		1.0 x 0.6	0.55	
2	LXES1TBBB2-004	0.55	6	9	1.6 x 1.6	0.55	
	LXES1TBAA2-013		6	9			
4	LXES1TBAA4-005	1.30	6	9	1.6 x 1.6	0.6	
	LXES2SBAA4-016	0.55	6	9			
	LXES2SBBB4-026	1.00	6	9	2.9 x 2.8	1.45	
	LXES2TBBB4-028	0.50	6	10	2.5 x 1.0	0.6	
6	LXES4XBAA6-027	0.25	6	10	4.9 x 3.0	1.1	
	LXESEABAA6-046	0.27	6		4.1 x 2.0	0.4	
4 w/EMI Filter	LXES1WCAA4-038*	27	6		1.6 x 1.1	0.65	
8 w/EMI Filter	LXES3YCAA8-039*	27	6		3.2 x 1.1	0.65	
10 w/EMI Filter	LXES2QCAA4-040*	28	6		2.0 x 2.0	0.67	

*In Development

**at 1mA

Part Numbering System

LXES 15 A AA 1 -100

Murata ESD Series

Size Code	Size (mm)
03	0.6 x 0.3
15	1.0 x 0.5
1U	1.0 x 0.6
1T	1.6 x 1.6
2T	2.5 x 1.0
2S	2.9 x 2.8
EA	4.1 x 2.0
4X	4.9 x 3.0
1W	1.6 x 1.1
3Y	3.2 x 1.1
2Q	2.0 x 2.0

Material
A = Ceramic
B = Si-based
C = Si-based with integral EMI filter (in development)

Control Code
1

of Channels
AA

Serial Number
-100

Application Examples

Antenna Port Protection

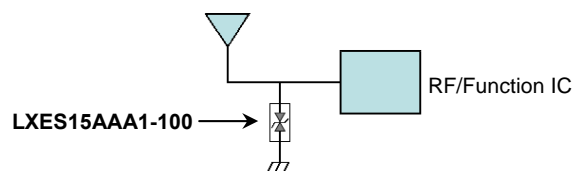

USB2.0 Single Port Protection

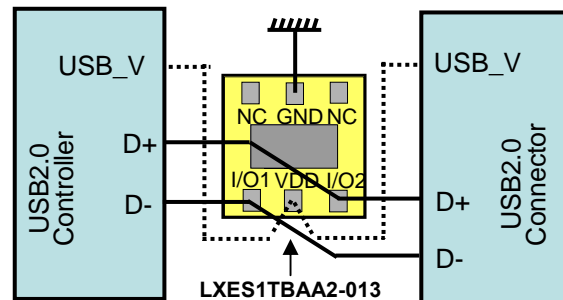

ESD Test Measurement System

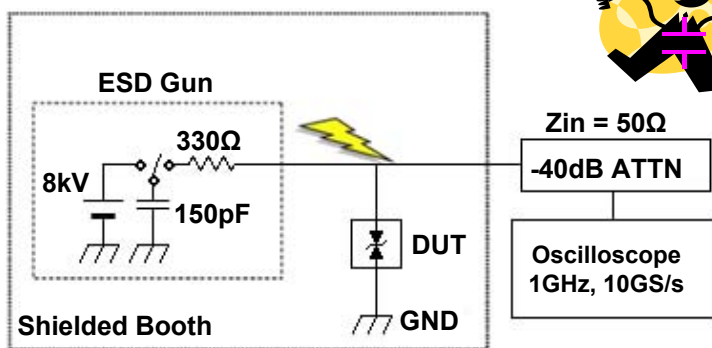

The human body can function as a capacitor with a capacitance of 70 to 150pF. Under the correct relative humidity conditions, the human body can build up a charge as high as 35kV. Most of us have experienced this by touching a metal surface on a cold winter day after having walked across a carpeted floor. The diagram below demonstrates how the addition of an ESD protection device can help protect electronic equipment against the electrostatic discharge.

IEC61000-4-2 ESD 8kV Direct Contact resultant Waveforms

