

The Digital Imperative:

THE RISING WAVE IN POWER FACTOR CORRECTION (PFC) TECHNIQUES

By Celite Mildbrandt, Power Factor Correction Marketing Manager, Cirrus Logic Inc.

With the push toward more efficient energy usage, lower carbon footprints and resource sustainability gaining momentum throughout the world, virtually every aspect of energy generation and consumption is coming under intense scrutiny for improvement. Much of the media buzz has centered upon such “big picture” sweeping changes as smart power grids, wind and solar power, carbon sequestration, etc. However, equally important changes are also taking place on the consumption side of the equation, with the continuing development of new high-efficiency electronic products in support of sustainable energy supply and smart consumption. Utilities have increasing concerns with distortion to the voltage waveform supplied to their customers as well as the effects of non-linear loads on their distribution systems. The cost implications of low power factor in distribution infrastructures are apparent in added heating losses resulting in the early replacement of capital equipment. Cirrus Logic’s smart energy products improve power grid performance by introducing an innovative digital solution for power factor correction.

The significance of power factor correction (PFC) has long been visualized as a technology requirement for improving the efficiency of a power system network by compensating for the fundamental reactive power generated or consumed by simple inductive or capacitive loads. With the Information Age in full swing, the growth of high reliability, low cost electronic products have led utilities to escalate their power quality concerns created by the increase of such “switching loads.” These products include: entertainment devices such as Digital TVs, DVDs, and audio equipment; information technology devices such as PCs, printers, and fax machines; variable speed motor drives for HVAC and white goods appliances; food preparation and cooking products such as microwaves and cooktops; and lighting products, which include electronic ballasts, LED and fluorescent lamps, and other power conversion devices that operate a variety of lamps. The drivers that have resulted in this proliferation are a direct result of the availability of low-cost switch-mode devices and control circuitry in all major end-use segments: residential, commercial, and industrial.

CIRRUS LOGIC, INC.

2901 Via Fortuna
Austin, Texas 78746

United States

T +1-512-851-4000

F +1-512-851-4977

Toll-Free +1-800-888-5016

SALES SUPPORT

North America +1 800-625-4084

Asia Pacific +852 2376-0801

Japan +81 (3) 5226-7757

Europe/UK +44 (90) 1628-891-300

LEARN MORE AT

www.cirrus.com



In order to keep power quality under the limits proposed by standards, it is required to incorporate some sort of compensation. There are two basic types of PFC circuits: active and passive. The simplest power factor correctors can be implemented using a passive filter to suppress the harmonics in conjunction with capacitors or inductors to generate or consume the fundamental reactive power, respectively. Active power factor correction circuits have proven to be more effective, generally integrated with the switch-mode circuitry, and actively control the input current of the load. This enables the most efficient delivery of electrical power from the power grid to the load. The demand for new smart, green products has set the stage for a worldwide migration from antiquated passive circuits to active correctors as well as from traditional analog technology to digital techniques. New digital active power factor correction delivers better full- and light-load power efficiency while lowering system costs, enabling smaller designs and providing a clear path for further feature enhancements and improved competitive positioning for a whole host of consumer and industrial products. Cirrus Logic’s novel advances in digital active PFC technology signify a major enabling element in the development of the newest generation of low cost, energy-efficient switch mode products.

This paper provides an overview of the global trends, environmental issues and regulations that are currently shaping the future of product-related energy efficiency and are making PFC functionality an increasingly important requirement for a widening range of products. In addition to reviewing the regulatory issues in various countries and regions that are mandating ever-tighter controls over power efficiency, we will also explore the overall “green energy” trends that are pushing power efficiency to the forefront as a competitive consideration in product design.

THE MAGNITUDE OF THE CHALLENGE

One good example of the many efforts in this area is the Climate Savers Computing Initiative, a nonprofit group of eco-conscious consumers, businesses and conservation organizations, started by Google and Intel in 2007, which has a goal to promote the development, deployment and adoption of smart technologies that can both improve the efficiency of a computer’s power delivery and reduce the energy consumed when the computer is in an inactive state. This Initiative seeks to reduce global CO2 emissions from the operation of computers by 54 million tons per year, which is equivalent to the annual output of 11 million cars or 10–20 coal-fired power plants. If successful, this effort will lead to a 50 percent reduction in power consumption by computers by 2010, and committed participants could collectively save \$5.5 billion in energy costs.

Similarly, the European Environmental Bureau (EEB) has estimated that just by reducing excess energy wasted by the inefficiency of power adapters in light to no-load states, also referred to a standby mode, the E.U. could save as much as 80 TeraWatt Hours of electricity per year (equivalent to the energy generated by eleven power stations). Today the most rewarding and abundant renewable energy resource is realized by reducing energy lost in transmission along the electrical distribution lines and at the point of delivery.

POWER FACTOR CORRECTION: WHAT AND WHY?

Power Factor (PF) is one of the first concepts introduced in a basic course on AC circuit theory. Despite its apparent simplicity, it is frequently misunderstood and misapplied due to misconceptions about the fundamental definition. The growing level of harmonic currents generated by modern electronic devices has prompted government and industry to look closer at the link between poor PF and harmonics created by “switching loads.”

Power factor is traditionally defined as the phase difference or displacement angle between sinusoidal voltage and current waveforms created by linear AC loads (i.e. simple resistive and reactive loads). When the AC load is partly capacitive or inductive, the current waveform is out of phase with the voltage requiring additional AC current to be generated that is not consumed by the load. These electrical losses (I²R) are consumed by the power delivery system, e.g. power cables, transformers, etc. If the AC load is non-linear (i.e. current does not vary smoothly with voltage as in “switching loads”), the complex waveform’s PF is resolved into a fundamental frequency and its harmonics. Switching mode power supplies (SMPS) are a good example of non-linear loads. SMPS conducts current in short pulses that are in phase with the line voltage but is not a pure sine wave creating line harmonics. These harmonic currents do not contribute to the load power.

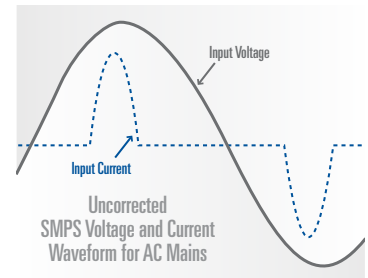

ENERGY STAR® Version 2.0 for External Power Supply defines true power factor as the ratio of the active, or real, power (P) consumed in watts to the apparent power (S), drawn in volt-amperes (VA).

$$PF = \frac{P}{S}$$

This definition of power factor includes the effect of both distortion and displacement.

Power factor correction (PFC) is a feature designed into the pulse width modulation (PWM) controller to help regulate, stabilize, and provide the requirements for higher load current and instantaneous current. The ideal objective for PFC is to drive the power factor as close to unity as possible, making the load circuitry power factor corrected and the apparent power equal to the real power.

An effective power electronic circuit that controls the amount of power drawn by a load in order to sustain a power factor as close as possible to unity is an active PFC. Active PFC circuits control the load current in addition to shaping the input-current waveform to follow a sinusoidal reference, the AC mains voltage.

STRIVING FOR EFFICIENCY

Energy efficiency at full load has always been critical for power supply systems. Recently, however, the focus has shifted to efficiency over the entire load range. This is because power supply systems spend significant time operating at mid-, light- and no-load (standby). New standards and regulations have been introduced to address this shift.

Efficiency is the ratio of the energy output of a product to the energy input, expressed as a percentage. Since switch mode devices require more energy than they provide, some energy is lost. Energy “escapes” in a number of places, I²R losses usually account for a significant portion of the total losses, producing heat in the components. For example, as the harmonic content of the current increases, skin effect losses increase greatly in the conductors and eddy current losses are exhibited as electrical losses in iron core components.

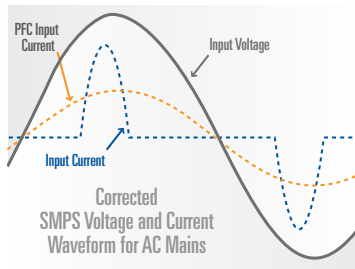

To meet AC line-emission harmonic standards, manufactures must add PFC techniques to the switch mode circuitry, saddling the design with added cost, an efficiency hit, and a larger PCB footprint. The designer is now challenged with optimizing some aspects of the PFC switching circuit in order to avoid design digression. An active power factor correction controls the load current waveform so that it’s proportional to the AC mains voltage waveform. A digital active power factor

correction lowers circuit component count and cost, plus it maintains a high efficiency rating when powering light or no loads. Although many switch-mode devices are designed for maximum efficiency, losses will never be eliminated.

The bottom line is that improvements to power efficiency are applicable for virtually any product that uses electricity, since all of the power savings at the end user level (whether consumer or industrial) will ultimately help reduce overall consumption and will ease the demand for power generation—with inherent beneficial environmental impacts.

Ultimately, PFC is required because standards and regulations demand it. That point notwithstanding, there are many benefits. PFC is good for the environment, good for the user (e.g. cost savings), and good for the product manufacturer (competitive advantage/regulatory compliance). As in the products shown below, Power Factor Correction can be an important factor for a variety of power sources (AC/DC adapters, switching power supplies, merchant supplies, and ballast systems) that are incorporated in a wide range of products, such as office lights, HVAC, computers, consumer electronics, appliances and many others.

A WORLD OF DIFFERENT REGULATIONS: ALL POINTING IN THE SAME DIRECTION

Product designers with responsibility for power consumption have always faced a somewhat fragmented global regulatory environment—and that’s still the case today. Perhaps the good news is that with the global movement toward greener products there is at least a commonality of the overall trends, if not of the explicit metrics and specifications. One of the most visible certifications worldwide with energy specifications is the U.S. ENERGY STAR®, sponsored by the Department of Energy (DoE) and the Environmental Protection Agency (EPA).

U.S. ENERGY STAR® is working closely with countries around the globe to harmonize efficiency standards. ENERGY STAR International is spearheading this effort which should help ease the challenges for EPS designers trying to create products that adhere to the new power efficiency specifications. For example, the ENERGY STAR® Program Requirements for Single Voltage External Ac-Dc and Ac-Ac Power Supplies Version 2.0 specification currently mandates that standard model external power supplies in active mode with outputs >49 watts have a power factor ≥ 0.870 (or ≥ 0.860 for low voltage models) and those with outputs >1 to ≤ 49 watts must have a power factor >0.622 (or >0.622 for low voltage models).

Another ENERGY STAR® initiative is to influence the manufacturing of qualified stationary and portable computers to be energy efficient. ENERGY STAR® Program Requirements for Computers Version 5.0 was adopted by the EPA and EC (European Commission) to go into affect July 2009. The partner agreement compliments the ENERGY STAR® Version 2.0 for External Power Supply with requirements for Computers Using an Internal Power Supply. ENERGY STAR® qualified internal power supplies are required to meet power performances of 85 percent minimum efficiency at 50 percent of rated output and 82 percent minimum efficiency at 20 percent and 100 percent of rated output, with Power Factor ≥ 0.9 at 100 percent of rated output.

As a traditional leader in product performance and safety requirements, the European community has also recently adopted more stringent energy efficiency standards. In April 2009, the EC (European Commission) mandated a series of tightening requirements, aimed at banning inefficient power adapters—such as those used to power laptops, mobile phone chargers and a variety of other devices. These new specifications start taking effect in April 2010 and are targeted to increase overall power efficiency by over 30 percent by 2020. According to one European Union Energy Commission spokesperson, these enhanced performance standards for external power supplies mean “the European Union (E.U.) could save enough electricity



by 2020 to power Lithuania for a year.” One key goal of the new E.U. mandates is to reduce the “phantom power draw” when devices are either not in use or in standby mode. As long as a power supply is plugged into the wall, its circuitry is consuming power even when not powering a useful load. The high level of standby and off-mode power draw is estimated to currently account for as much as 10 percent of the overall electricity used in homes and offices throughout the E.U.

A variety of other regulatory factors also need to be taken into consideration, when designing for power supply efficiency. These include Harmonics Standard IEC 61000-3-2, which has long included PFC definitions and requirements. Also important are the specifications from the 80PLUS Energy Efficient Technologies organization, which is a utility-funded incentive program that sets efficiency standards and certifies power supplies for compliance. In addition, a number of jurisdictions are establishing their own specifications, such as California’s Title 24, which establishes energy efficiency requirements for buildings and facility operation.

circuit and components, making it difficult to almost impossible to meet PFC standards across all loads. A digital power factor correction circuit eases the difficulty in obtaining the required efficiencies at light loads and the absence of a load, allowing the power supply designer to sustain the active PFC stage across all load conditions – thereby simplifying the design of the second stage.

Cirrus Logic is introducing innovative power factor correction techniques for switch mode power converter using digital PWM control algorithms. The new CS1500 and CS1600 Digital Power Factor Correction ICs strive to achieve sinusoidal input current waveform proportional to the input voltage waveform. To align the two input waveform’s shape and phase, switching is carried out using digital techniques. Also the input voltage feed-forward compensation network makes the output voltage insensitive to the input voltage and guarantees sinusoidal input current even if the input voltage is distorted.

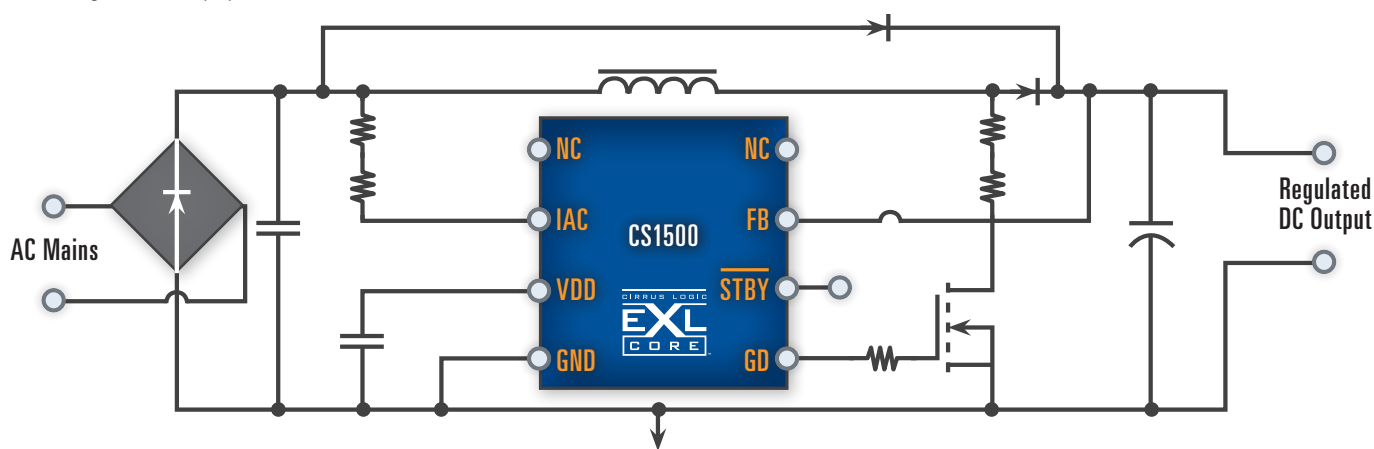

Going forward, product manufacturers will need to design for compliance with those regulations that control the largest markets, such as the U.S., Europe, Asia, and also consider the trade-offs of designing to meet additional jurisdictional requirements. When major regulatory bodies address the same factors, it will be important for designers to always comply with the tightest rating for each metric and also to “get out in front” of the escalating trends in efficiency mandates in order to ensure continued compliance.

At the same time, designers will need to reduce costs and parts count in order to more cost-effectively incorporate Power Factor Correction into a wider range of products, both to meet expanding regulatory requirements and to enhance the competitiveness of their product offerings.

DIGITAL PFC – THE MOST EFFICIENT WAY FORWARD!

Power efficiency is a fundamental characteristic of any switch mode device, and its measure generally dictates the power quality of the conversion device. To qualify for ENERGY STAR® Single Voltage External Ac-Ac and Ac-Dc Power Supplies, the switch mode device must comply with an average efficiency higher than 87 percent for output load between 25 percent and 100 percent of the nominal load and no-load consumption lower than 500mW. This puts serious constraints on the design of the power supply

In digital implementation of average current mode control, the PFC processing logic is used to calculate the duty cycle in every switching cycle, based on the feedback and reference currents. The switch is controlled by the calculated duty cycles to achieve unity power factor. The system has an analog-to-digital converter to sample the output voltage, a computational unit to determine the value of the switch duty ratio, and a digital pulse-width modulator that outputs a pulsating waveform that controls the switch in the converter at the computed duty ratio.

In light of new government and industry standards and regulations requiring increased power-usage efficiency, the incorporation of PFC functionality is simultaneously becoming more critical and more challenging. The combination of different types of smart energy products needing PFC along with increasing mandates for overall efficiency across the whole load range are taxing traditional analog PFC techniques currently in use. It has now become clear that a fresh design approach will be required to meet these new requirements.

By leveraging advanced mixed-signal and digital-signal processing techniques, the newest generation of Digital Power Factor Correction devices is now able to deliver unprecedented performance and correction capabilities across the full spectrum of load levels (including much lighter loads than previously possible).

As shown in the comparison graph, a digital PFC device is able to maintain a consistently high efficiency (well above 90 percent efficiency) even at low current power levels, whereas the efficiency of a traditional analog approach drops off dramatically at lower load ranges. This not only allows the Digital PFC device to meet increasingly tighter regulatory demands it also enables designers to deploy a common solution across a wider range of products and product families.

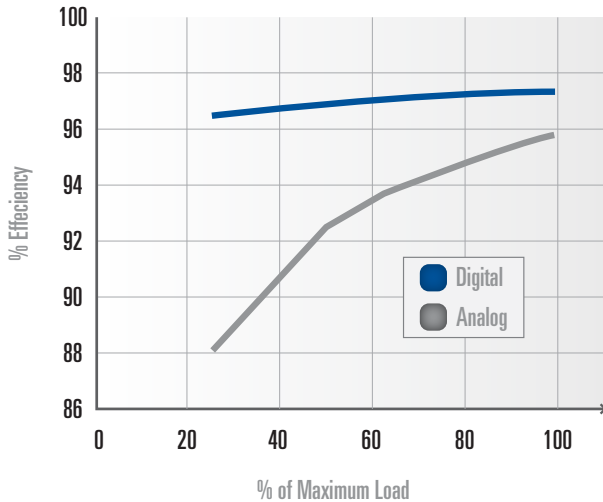

These new single-chip digital PFC solutions are also much more cost effective from a bill of materials standpoint than the traditional analog approaches that often require as many as 30 percent more discrete components to implement. Some other important benefits of the digital PFC approach include significantly reduced Electromagnetic Interference (EMI) concerns that can enable smaller or fewer EMI filters on the board design (saving money and space), as well as the inherently higher reliability of using a single device with fewer discrete components.

TANGIBLE BENEFITS IN THE REAL WORLD

While the standards and objectives of various regulatory and environmental organizations may vary, the primary goals they have in common are to:

1. Reduce power supply/conversion losses
2. Reduce energy transmission and distribution losses
3. Reduce idle power

The move to Digital Power Factor Correction is key to addressing these goals:

- ✓ Higher Power Supply Efficiency delivers more Converted-Watt/Raw-Watt
- ✓ Higher PF reduces generation, transport and distribution losses in the Power Utilities wires, transformers and alternators.
- ✓ Reducing Idle Power usage helps stem the mighty river of consumption made of many small droplets from dozens of devices in every household that are consuming anywhere between 0.1 and 20W on a 24-hour/7-day per week basis.

Moving forward, digital power factor correction is destined to become the de facto design methodology for assuring compliance with increasingly stringent requirements for improved power efficiency in each new generation of electricity-using products. It also will help lower costs and improve design flexibility for manufacturers to leverage “green” product characteristics to their competitive advantage. But most importantly, digital PFC capabilities will provide another key link in the chain of energy-saving factors that will ultimately help reverse the over-consumption trends of recent decades and will contribute to the overall reduction of the global carbon footprint.

