

# ENERGY HARVESTING WIRELESS SWITCH



In a world with an increasing number of networks, the requirements of information transmission are also changing: It needs to be mobile and flexible – using as little energy as possible. The answer is Energy Harvesting wireless switches made by Cherry. They are easy and effective to use, without any cables or batteries.

Breaking new ground means using intelligent technologies: Energy Harvesting makes use of energy which is already available. Rather than requiring energy to be generated by an external supply or an integrated source, Cherry’s Energy Harvesting products convert energy that is already available to the system.

**Energy Harvesting with an inductive generator**

Cherry’s Energy Harvesting switch module works on an inductive basis. The inductive pulse generator converts the mechanical operating force of the operator into an electrical energy pulse. When the pulse generator is

operated, the magnetic flow is reversed in a coil system, creating electrical energy. This energy is converted in the energy management system into a constant supply voltage stretched out over time. This powers the radio electronics with transmitting antenna to send a radio signal. The great advantages this provides: Due to its miniature construction, the high degree of efficacy in the functional chain and the long service life of up to 1,000,000 switching cycles, the Cherry wireless module only needs a small amount of power for operation with no maintenance required – and can be installed in a tight space.

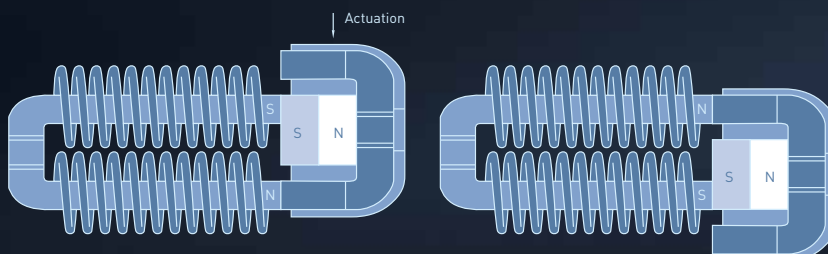

Intelligent energy converter: The inductive generator converts mechanical energy into an electrical energy pulse by continuously changing the direction of the magnetic field.

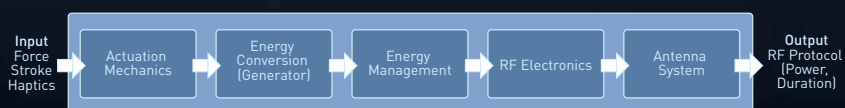

Energy Harvesting with the self-powered functional switch: It converts the incoming mechanical energy from operating the switch into electrical energy which sends pulses to a radio receiver via radio electronics.

### Best connections – for industry and building technology

Various radio standards can be used for transmission: from ZF proprietary to ZigBee Greenpower, right up to customer-specific requirements. An excellent option for integration into building automation is provided by the worldwide bus standard KNX. This has been developed in recent years, starting from a purely cabled approach, then to wireless technology, to fully integrated wireless technology with central configuration using the software tool ETS. It is now being expanded with the new wireless switch module which integrates the Energy Harvesting aspect: Operating the switch module generates enough electrical energy to send a complete KNX-RF protocol directly to a KNX receiver of your choice. A gateway is not required. The scope of the transmitter reaches up to 30 meters in buildings (868.3 MHz band).

### One advantage after another

This environmentally friendly system has numerous advantages:

You have the flexibility to install a switch in any location you want without cabling, where it fulfills its function over the entire length of its service life without any maintenance at all – including battery changes.

In contrast to information transmission via cables, the self-powered wireless switch is attractive for building services, as it is also easy to retrofit. For example, you can install new light switches in a freshly decorated room without having to cut any holes in the wall.

There are also numerous possibilities for use in industrial automation, and particularly if the time it takes to lay cables is disproportionate to the application.

<u>Energy Harvesting wireless switch</u>	<u>2/3</u>
<u>Standard transmitter – components</u>	<u>4</u>
<u>Standard transmitter – wireless switch with housing</u>	<u>5</u>
<u>Standard receiver</u>	<u>6</u>
<u>Transmitter /KNX for building automation</u>	<u>7</u>



Generator momentary



Generator maintained

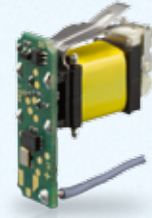

Generator with PCB

## Generators – Features

- Inductive generator: The required RF-energy is created by the mechanical actuation of the switch
- Miniature design combined with extremely high energy output
- Long mechanical life
- Momentary design: Switching mechanism returns to starting position after release
- Maintained design: Switching mechanism with two rest positions (e.g. On-Off)

## Generator with PCB – Features

- Energy Harvesting system with no wires, consisting of generator and transmission electronics
- Wireless data transfer via RF technology
  - saves on plug connections
  - easy to install in virtually inaccessible areas
  - no complex wire assembly
- Several available frequency bands allow use worldwide in a range of applications
- Maintenance-free – no batteries that need to be replaced
- Flexible “Pairing” allows the operation of several receivers with one switch (and vice versa)
- “Unique ID” excludes a mutual interference between different RF-switches

## Technical Data

Series	Generator – momentary	Generator – maintained	Generator with PCB
Dimensions	20.1 x 7.3 x 14.3 mm	20.1 x 7.3 x 19.3 mm	21.7 x 7.3 x 23.3 mm
Energy generated	2x min. 0.33 mWs	1x min. 0.33 mWs	–
Lifetime	up to 1,000,000 operations	min. 100,000 operations	up to 1,000,000 operations
Operating force	approx. 13 N	5–16 N (depending on the lever length)	–
Temperature range	-40 to +85 °C (-40 to +185 °F)	-40 to +85 °C (-40 to +185 °F)	-40 to +85 °C (-40 to +185 °F)
Frequency bands	–	–	868.3 MHz or 915.0 MHz

## Dimensions in mm

Momentary generator

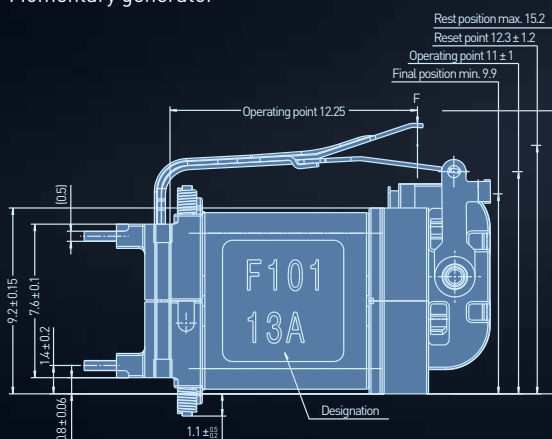

Maintained generator

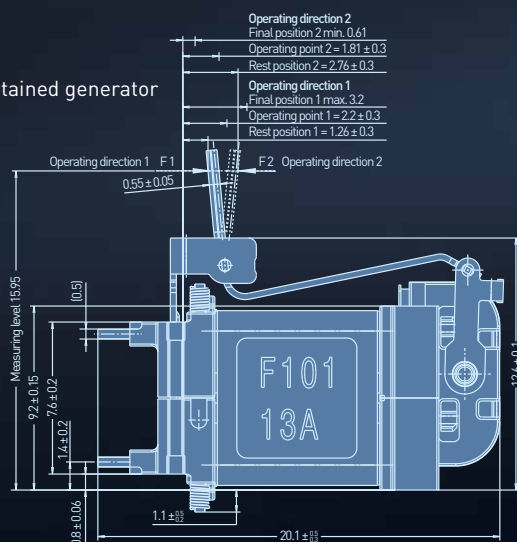

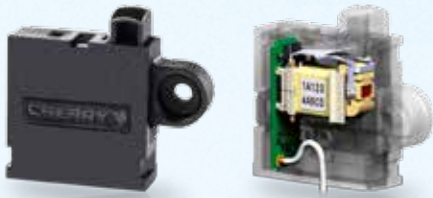

Energy Harvesting wireless snap switch



Energy harvesting wireless rocker switch

## Features

- Energy Harvesting, wireless system
- Miniature design combined with extremely high energy output
- Wireless data transfer via RF technology
  - saves on plug connections
  - easy to install in virtually inaccessible areas
  - no complex wire assembly
- Energy Harvester without a battery: The required RF-energy is created by the mechanical actuation of the switch
- Several available frequency bands allow use worldwide in a range of applications
- Maintenance-free – no batteries that need to be replaced
- Long mechanical life
- Flexible “Pairing” allows the operation of several receivers with one switch (and vice versa)
- “Unique ID” excludes a mutual interference between different RF-switches
- Compatible radio receiver available
- Protocols are sent multiple times and delayed to assure a robust data transmission
- Proprietary ZF RF-protocol
- Snap switch also available with auxiliary actuator options

## Technical Data

Series	Energy Harvesting wireless switch	Energy Harvesting wireless switch
Design	Snap switch, momentary	Rocker switch, momentary
Temperature range	-20 to +60 °C (-4 to +140 °F)	-20 to +60 °C (-4 to +140 °F)
Lifetime	min. 100,000 operations	min. 100,000 operations
Frequency bands	868.3 MHz or 915.0 MHz	868.3 MHz or 915.0 MHz
RF distance (open area)	up to 300 m	up to 300 m
RF distance (in buildings)	up to 30 m	up to 30 m
Operating force	max. 15 N	max. 8 N
Operating speed	0.05–0.25 m/s	0.05–0.25 m/s
Housing protection class	IP40	IP40

## Dimensions in mm

Snap switch

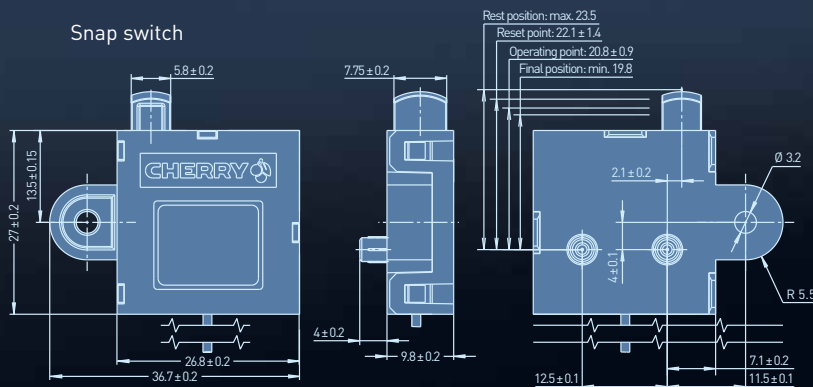

Rocker switch

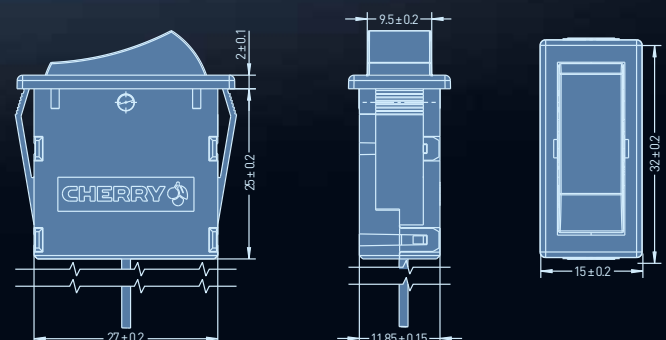



Receiver module for self-powered wireless switch



Receiver PCB

## Receiver with housing – Features

- Standard receiver module for Energy Harvesting wireless switches
- Various output options
- Suitable for wall installation
- Designed for frequency bands in Europe (868.3 MHz) or North America (915.0 MHz).
- Flexible “Pairing” allows the operation of several receivers with one switch (and vice versa)
- “Unique ID” excludes a mutual interference between different RF-switches
- Compatible wireless switch (switch, rocker switch) available
- Repeater function possible for greater distances
- Proprietary ZF radio protocol

## Receiver only – Features

- PCB as stand-alone product for Energy Harvesting wireless switches
- Designed for frequency bands in Europe (868.3 MHz) or North America (915.0 MHz).
- Flexible “Pairing” allows the operation of several receivers with one switch (and vice versa)
- “Unique ID” excludes a mutual interference between different RF-switches
- Compatible wireless switches (snap switch, rocker switch) available
- Reflow can be soldered
- Can be used as stand-alone or pure communication module
- Repeater function possible for greater distances
- Proprietary ZF radio protocol

## Technical Data

Series	Receiver module	Receiver PCB
Temperature range	-40 to +85 °C (-40 to +185 °F)	-40 to +85 °C (-40 to +185 °F)
Receiver sensitivity	typ. -98 dBm	typ. -98 dBm
Receiver class	Class 2	Class 2
Supply voltage	5 V DC stabilized or 7 V to 24 V DC unstable, 5 V USB	5 V or 3.3 V DC
Output interfaces	Low voltage relay 48 V or 230 V; TTL, RS232 or RS485 Bus; Digital output (high/low) or SPI; USB 2.0	1x UART 4x GPIO
Frequency bands	868.3 MHz or 915.0 MHz	868.3 MHz or 915.0 MHz
Antennae	Wire antenna with plastic sleeve 50 Ohm output	Wire antenna 50 Ohm output

## Dimensions in mm

### Receiver with housing

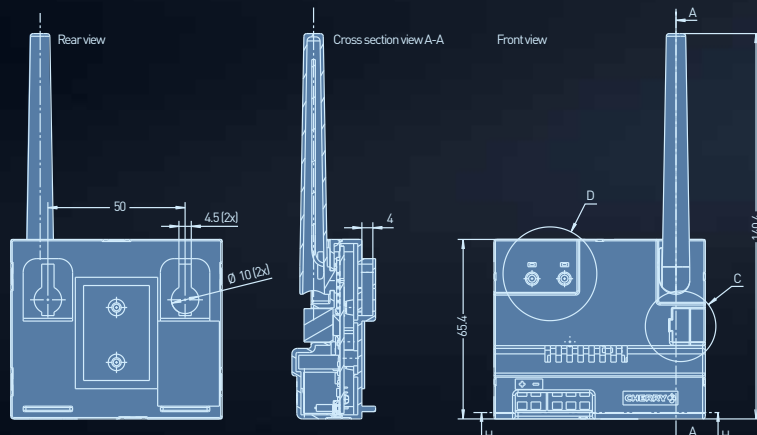

### Receiver only

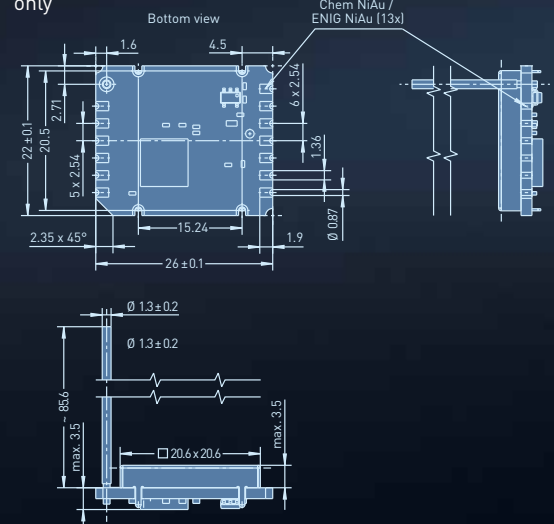



1-way switch module



2-way switch module



Pairing adapter

## Switch module – Features

- Self-powered, wireless switch module for building automation (e.g. for controlling lights or blinds)
- Can be universally adapted for customer-specific design parts
- Available as 1-way button or 2-way button (also serial button)
- Several available frequency bands allow use worldwide
- Several radio standards can be implemented (KNX-RF, EnOcean, ZigBee, ZF-proprietary ...)
- Low operating force and low operating noise
- Maintenance-free – no batteries that need to be replaced
- Easy to install, even in virtually inaccessible places
- Protocol-dependent pairing
- Optional adapter for power supply during configuration

## Standard receiver KNX

Compatible with all KNX-RF receivers which are commercially available as standard

## Pairing adapter

Allows bi-directional communication during configuration

## Technical Data

Series	1/2-way switch module	KNX 1/2-way switch module
Frequency bands	868.3 MHz, 915 MHz, 2.4 GHz	868.3 MHz
Temperature range	-20 to +45 °C (-4 to +113 °F)	-20 to +45 °C (-4 to +113 °F)
Lifetime (generator)	min. 100,000 operations	min. 100,000 operations
RF distance (in buildings)	up to 30 m	up to 30 m
Operating force	6–12 N (can be designed for different versions)	>10 N
Radiated output power	depends on radio standard	up to 3 dBm
Transmission time wireless protocol	depends on radio standard	approx. 19 ms

## Dimensions in mm

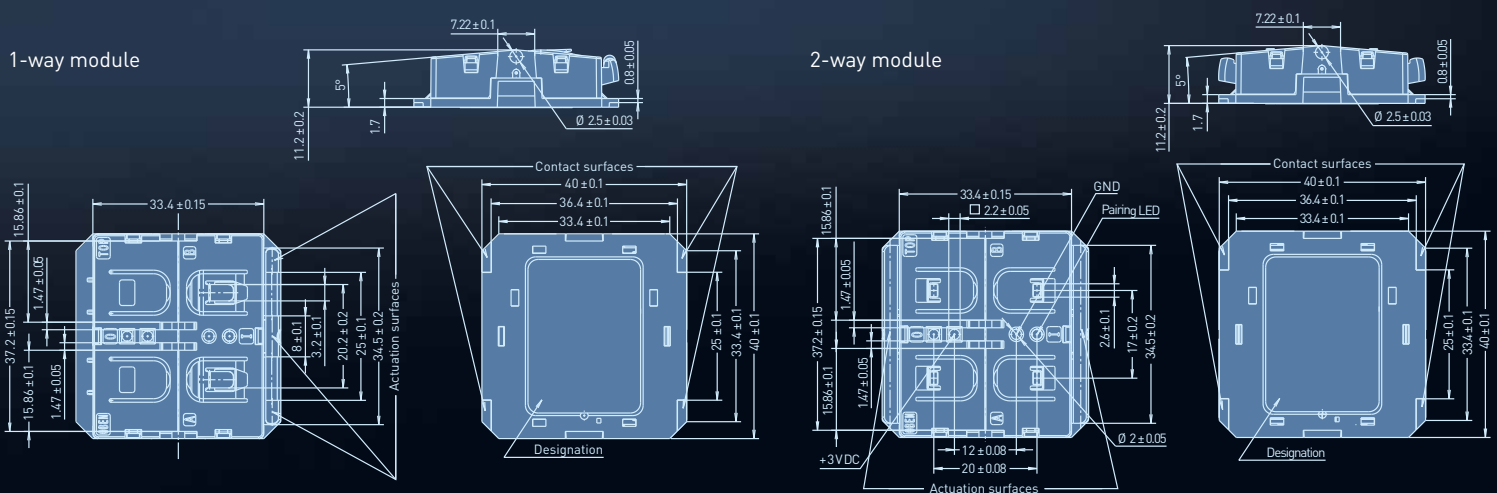

ZF Friedrichshafen AG  
Cherrystraße  
91275 Auerbach  
Germany  
Phone: +49 96 43 18-0  
Fax: +49 96 43 18 17 20

ZF Electronic Systems Pleasant Prairie LLC  
11200 88th Avenue  
Pleasant Prairie, Wisconsin  
USA 53158  
Phone: +1 262 942 6500  
Fax: +1 262 942 6566

ZF Electronics Asia Limited  
2 / F Technology Plaza  
29-35 Sha Tsui Road  
Tsuen Wan, New Territories  
Hong Kong  
Phone: +852 25 65 66 78  
Fax: +852 25 65 68 27

ZF Electronics TVS (India) Private Limited  
Madurai – Melur Road,  
Vellaripatti, Madurai – 625 122  
India  
Phone: +91 452 24 202 08  
Fax: +91 452 24 203 82

[www.cherryswitches.com](http://www.cherryswitches.com)

Subject to errors, technical changes, and delivery feasibility. Technical information only refers to the product specification. It does not warrant any specific properties. Binding information can only be found in drawings in association with product specifications.